

Balcrank

Fluid Dispensing Systems

Installation Guide

Synergy Monitoring System



CHAPTER

1. INTRODUCTION.....	3
2. COMMUNICATION-LOOP	3
2.1. WHAT IS A CURRENT LOOP	3
2.2. COMMUNICATION HARDWARE	4
2.3. CABLE RECOMMENDATIONS.....	4
2.4. COMMUNICATION LOOP FUNDAMENTALS.....	5
2.4.1. <i>All modules should be connected in a chain.</i>	5
2.4.2. <i>Only the two modules at the end of the chain should be terminated.</i>	5
2.4.3. <i>Interconnecting two power supplies must be avoided.</i>	5
2.4.4. <i>Communication cable length</i>	6
2.4.5. <i>How to check if a communication loop is OK</i>	6
2.4.6. <i>If the communication loop does not work properly</i>	7
2.5. REAL SYSTEM SAMPLES	8
2.5.1. <i>System with 1 active module and 1 passive module</i>	8
2.5.2. <i>System with 1 active and 3 passive modules</i>	8
2.5.3. <i>System with 2 active and 5 passive modules</i>	8
2.5.4. <i>PC based system with 2 active and 6 passive modules.</i>	9
2.5.5. <i>How to connect two already powered passive modules.</i>	10
2.5.6. <i>How to use the SIO as line amplifier.</i>	10
2.6. DROP-DOWNS (NOT RECOMMENDED).	11
3. ELECTRIC CONNECTION OF SOLENOID VALVES AND METERS.....	11
4. ELECTRIC CONNECTION NON STANDARD.....	12
4.1. GENERAL	12
4.2. COMMUNICATION-LOOP.....	12
4.3. SOLENOID VALVES	12
4.4. METERS.....	12
5. MECHANICAL INSTALLATION.....	12
5.1. PIPE WORK.....	12
5.2. SOLENOID VALVES	14
5.3. METERS.....	14
6. MODULES	14
6.1. IN GENERAL	14
6.2. MPDM MODULE (23 400)	15
6.2.1. <i>Mechanical installation</i>	15
6.2.2. <i>Electric installation</i>	15
6.2.3. <i>Technical specifications</i>	15
6.3. KP MODULE (23 401)	16
6.3.1. <i>Mechanical installation</i>	16
6.3.2. <i>Electrical installation</i>	16
6.3.3. <i>Technical specifications</i>	16
6.4. PM MODULE (23 402).....	18
6.4.1. <i>Mechanical installation</i>	18
6.4.2. <i>Electric installation</i>	18
6.4.3. <i>Technical specifications</i>	18
6.5. SIO MODULE (23 403).....	19
6.5.1. <i>Mechanical installation</i>	19
6.5.2. <i>Electric installation</i>	19
6.5.3. <i>Technical specifications</i>	19
6.6. LED MODULE (23 404)	20
6.6.1. <i>Mechanical installation</i>	20
6.6.2. <i>Electric installation</i>	20

6.6.3. Technical specifications.....	20
6.7. CM MODULE (23 405).....	21
6.7.1. Installation.....	21
6.7.2. Technical specifications.....	21
6.8. TCM MODULE (23 408) / TSM MODULE (23430).....	21
6.8.1. Mechanical installation.....	21
6.8.2. Electric installation	21
6.8.3. Technical specifications.....	22
6.9. GKP MODULE (23 401).....	22
6.9.1. Mechanical installation.....	22
6.9.2. Electrical installation	22
6.9.3. Technical specifications.....	23
7. CONFIGURATION.....	23
7.1. CHECK BEFORE CONFIGURATION	23
7.2. ADDRESSING THE MPDM	23
7.3. SET-UP MODE	24
7.4. SET ADDRESS [XX//ADDR]	24
7.5. RECOMMENDATION FOR SETTING ADDRESSES	24
8. USING A TERMINAL (KEYPAD).....	24
9. SETTING DATE AND TIME	26
9.1. SET [CLOCK/DATE] AND [CLOCK/TIME].	26
10.FAST MENU CODES	27

1. Introduction

Synergy is a flexible, module-based monitoring system, designed to handle all kinds of media with a large number of dispense-points. There is no mainframe to connect modules to, instead all modules connects through a communication port where all modules have a unique address and independent software. This makes it very easy to add or remove modules without affecting the entire system. All modules in a system communicate directly. The smallest possible system, with the least amount of modules is a MPDM (Multi Point Dispense Module) and a KP (KeyPad). All functions in the system are then accessed from the KP.

It is possible to add a PM (Printer Module) to the basic system. The PM includes a CENTRONIC parallel printer-port and a database for storage of information like dispensed fluid, tank content and authorized users. A receipt of dispensed fluid can be printed immediately or later.

An optional LED (LED-display) is available. This will display the amount of fluid dispensed and on which dispense-point.

To connect the system to a PC, use a SIO (Serial In and Out) and the Synergy Win-Tools software. A SIO can also be used as a signal-amplifier if the total communication-loop is too long.

More modules like tank-monitors will be added soon.

2. Communication-loop

SYNERGY is based on RS-485 which is a current loop standard with addressing possibilities. The reason for using a current loop is that a current loop is much more resistant to electromagnetic fields and similar disturbances.

2.1. What is a current loop

A current loop is a closed circuit with a current flow, the same current through all parts of the circuit.

Because of the basic electrical laws states this current loop is very insensitive to environmental disturbances. One thing that can disturb a current loop is if one or more loops are connected together, in this case the current will not be the same in all parts of the circuit.

*A current loop, **BLUE** in the picture below, is created when two electrical leads are connected to each other at both ends and an electric power supply is applied between them. To prevent a short circuit and to set an appropriate current the connection between the two leads is done by using resistors. These resistors (T) are called "termination".*

When using electric signals it is not good to use levels close to the power source minimum (in our case 0

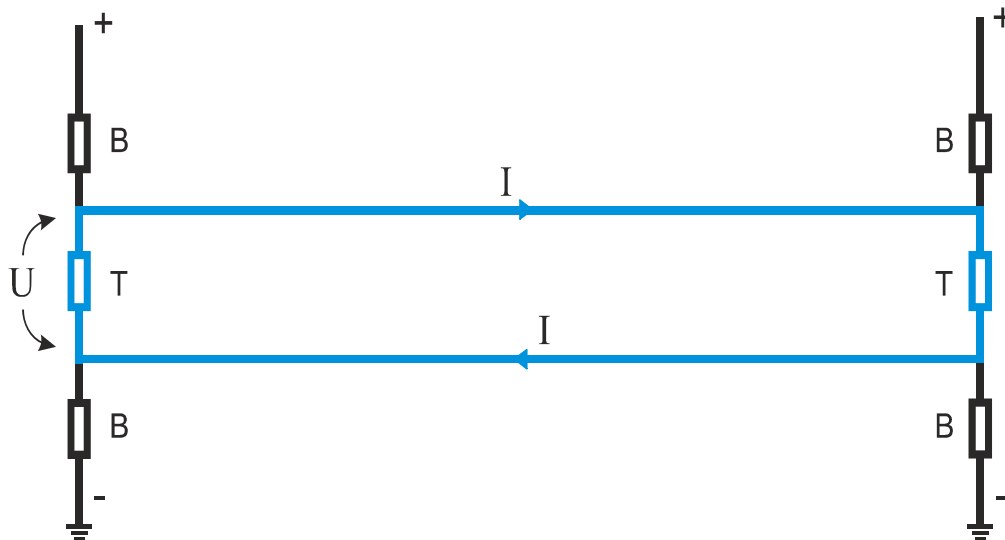

VDC) or maximum (in our case 5 VDC) levels. To avoid this the voltage level of the current loop is set by the use of resistors (B), this is called "biasing".

2.2. Communication hardware

All Synergy hardware modules except the SIO (PC-Interface) are equipped with one RS-485 current loop communication driver. The Synergy SIO (PC-interface) has two separate Synergy communication channels and because of this, it has two RS-485 current loop communication drivers.



For each driver there is a DIL-Switch that is used to handle the termination and biasing of the module.

DIL-switch 1 set termination.

DIL-switch 2 and 3 sets BIAS.

DIL-switch 4 is used to report termination status to the PC, only works on newer modules with newer software.

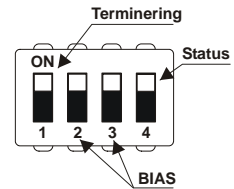
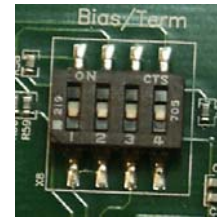

By setting DIL switches 1-4 in the **ON** position the specific module is terminated and biased.

Each module has a number of 4-pole communication connectors. Modules that has its own internal power supply has five connectors and modules that needs external power supply (from the communication loop) has two connectors. The SIO needs external power supply but has two communication channels and has because of this two times two connectors. The plug is keyed to prevent mistakes but make sure that the plug is sideways aligned before plug it in.



2.3. Cable recommendations

The communication cable between modules should be a twisted pair, pair shielded, cable with two pairs and each lead in the cable should have an area of 0.22 mm². One of the pairs is used for power supply (GND and +24VDC) and the other for communication (A and B). The recommended cable is Balcrank part number 23 411, or equivalent. Belden 8723 and complying with UL 2919. Balcrank recommends a multi thread cable.

If the Balcrank cable 23 411 is used colours should be used as below,

BLACK	used for	GND
RED	used for	+24V
GREEN	used for	B
WHITE	used for	A

A good practice is to twist each pair slightly before attaching them to the plug.

This simplifies support considerably.

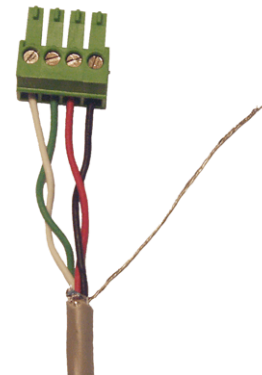

The shield lead should always be isolated to prevent short circuits and connected to the module steel box. As isolation the removed communication cable main isolation or another isolation “tube” can be used.

2.4. Communication loop fundamentals

The following picture is a schematic view of a Synergy system built up of 6 modules correctly connected and terminated.

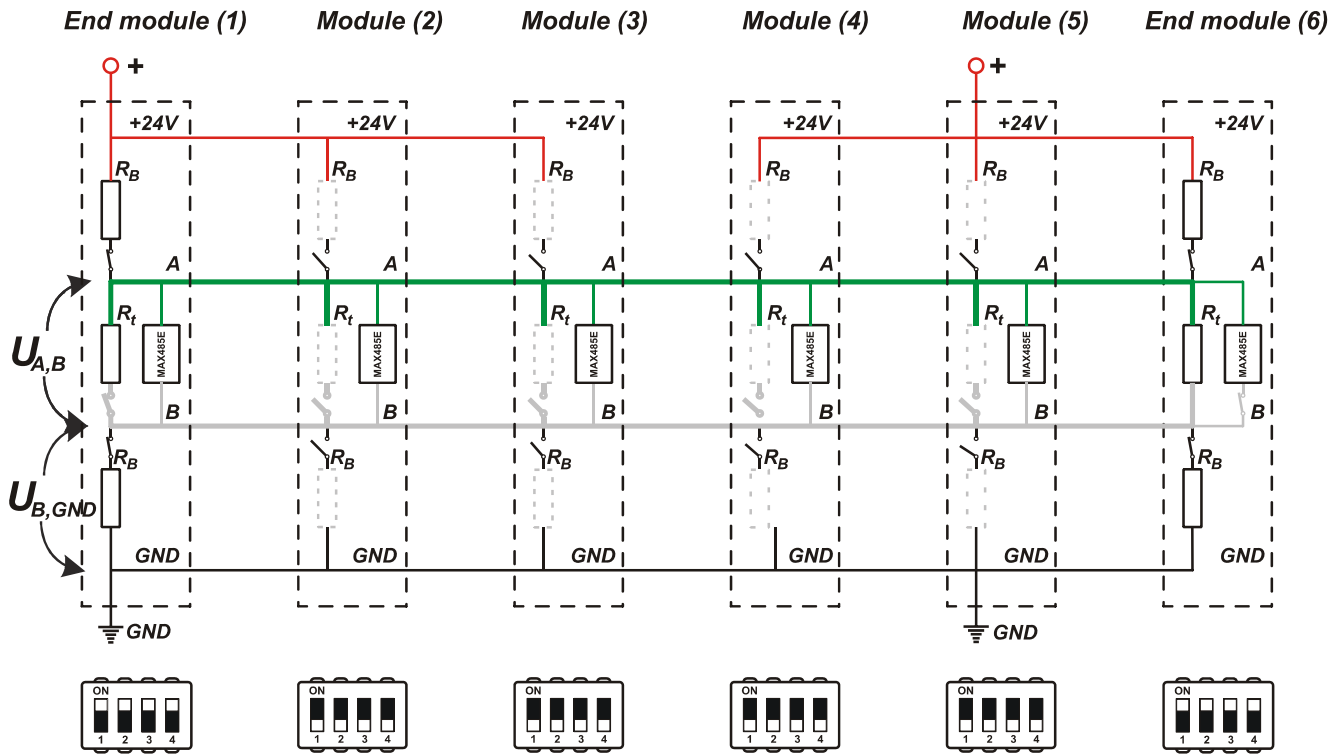

Where,

R_t = Termination resistors

R_b = Biasing resistors).

MAX485E = Communication driver.

+24V, A, B, GND = Communication connector poles.

2.4.1. All modules should be connected in a chain.

In the example all modules are connected in a chain with Module 1 in one end and Module 6 in the other end. In the end modules only one connector is used and in the modules in between two connectors are used.

2.4.2. Only the two modules at the end of the chain should be terminated.

In the example Module 1 and 6 that are at the end of the chain have all four switches of the DIL-Switch in the ON position. All modules between them have all four switches of the DIL-Switch in the OFF position.

Between Module 1 and 6 a “terminated loop” is achieved.

2.4.3. Interconnecting two power supplies must be avoided.

In the example Module 2 and 3 are passive modules (KP, PM, LED or SIO) powered by Module 1 (MPDM, TCM or TSM). Module 4 and 6 are also passive modules but powered by Module 5. Because of this the RED (+24V) must not be connected between them.

If there should be a connection between two already powered passive modules do not connect the RED cable between them.

If one or both of the powered modules are active modules use MPDM-IN and /or MPDM-OUT connector. The MPDM-IN and MPDM-OUT connectors do not have +24V connected.

2.4.4. Communication cable length

The specification for an RS485 current loop limits the total cable length of a terminated loop to 2000m. By using Synergy SIO modules (PC-interface) a long communication loop can be split into several 2000m loops.

With one 2000m loop add a SIO in one end and you can add 2000m more and so on.

2.4.5. How to check if a communication loop is OK

See figure chapter 2.4 above.

In a Synergy system the following table can be used as a guide to check if the communication loop is done correctly and has no broken drivers.

The voltages in the table are average values taken from measures on a few lab systems and can be up or down a little more depending on individual modules and communication cable lengths. The values should be seen as indication.

System correctly connected and terminated with no broken drivers.			
System	UA,B	UB,GND	Comments
A single terminated and powered module.	0.47 – 0.55 VDC	2.0-2.20 VDC	This is the easiest way to test the driver on a module. Make sure that all termination switches are in the ON position.
5 modules	0.49-0.51 VDC	1.95-2.05 VDC	End modules terminated
10 modules	0.48-0.50 VDC	1.70-1.80 VDC	End modules terminated
15 modules	0.47-0.49 VDC	1.55-1.65 VDC	End modules terminated
20 modules	0.46-0.48 VDC	1.40-1.50 VDC	End modules terminated
25 modules	0.45-0.47 VDC	1.30-1.40 VDC	End modules terminated

Generally one can say that

- The specification of the driver MAX485E voltage (**UA,B**) must be greater than 0,2 V
- A single terminated module should have about **UA,B** = 0.5 VDC / **UB,GND** = 2 VDC
- **UA,B** decrease a little as the system grows.
- **UB,GND** decreases about 0.05 VDC per module (a few modules) and lesser as the number of modules increase.

2.4.6. If the communication loop does not work properly

The Synergy communication loop is based on the RS-485 electrical standard. It is a serial differential current loop that is very robust and secure against environmental influence.

Because it is so robust systems will often appear to work fine even with faults. The bigger the system is the more important it is to make it correct.

It is also very important to make it correct to make the system comply with the electric CE-directives.

A proper system with typical errors added. (Values are highly dependent of system size and how it is connected.)			
System	UA,B	UB,GND	Comments
A single terminated and powered module with broken driver, some samples.	0.87 VDC 0.43 VDC 0.19 VDC	0.26 VDC 1.11 VDC 1.83 VDC	The result depends on how it is broken. The common thing is that the values differ a lot from the normal about 0.5 and 2 VDC.
5 modules	0.01 VDC	0.03 VDC	No modules terminated
25 modules	0.46 VDC	0.9 VDC	Only one end module terminated
25 modules	0.3 VDC	0.03 VDC	No modules terminated
25 modules	0.48 VDC	1.55 VDC	Three modules terminated.
25 modules	0.48 VDC	1.65 VDC	Four modules terminated
25 modules	0.48 VDC	1.8 VDC	Five modules terminated. With five modules terminated usually a lot of strange and random errors will occur.
25 modules	0.78 VDC 0.45 VDC 0.15 VDC	0.21 VDC 0.84 VDC 1.93 VDC	Broken driver or drivers. The result depends on how and how many that it is broken. The common thing is that the values differ a lot from the normal about 0.5 and 2 VDC.
25 modules	0.70 VDC	1,66 VDC	End modules terminated and switch 2 on another module in ON position.
25 modules	0.53 VDC	1,12 VDC	End modules terminated and switch 3 on another module in ON position.
25 modules	0.68 VDC	1,43 VDC	End modules terminated and switch 2 and 3 on another module in ON position.

2.5. Real system samples

To show how to build a Synergy system according to the above rules this chapter shows some examples

An active module is a module with power supply such as MPDM, TCM and TSM.

A passive module is a module that does not have a power supply such as KP, GKP, SIO, PM and LED.

2.5.1. System with 1 active module and 1 passive module

In a system with only two modules, one MPDM and one KP, both modules should be terminated and biased because they are at the ends of the loop.

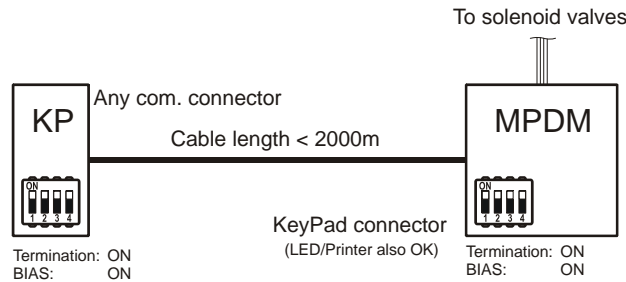

2.5.2. System with 1 active and 3 passive modules

In a system with one active module (MPDM) and a number of passive modules, termination and bias should be set on the two modules at the ends of the communication loop.

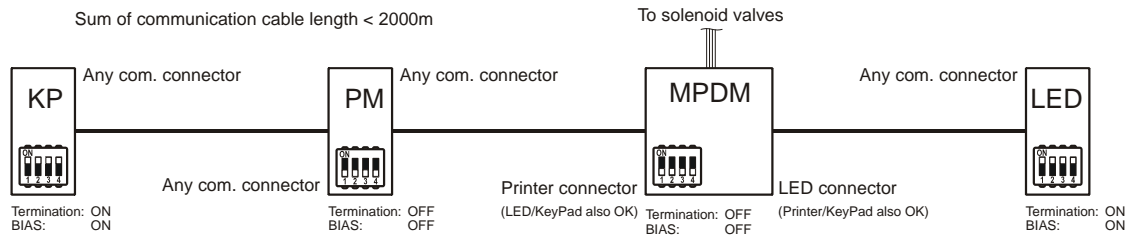

2.5.3. System with 2 active and 5 passive modules

In a system with two active module (MPDM) and a number of passive modules, termination and bias should be set on the two modules at the ends of the communication loop. The communication between two active modules should not have the +24V line connected and this is solved by using MPDM In and MPDM Out connector that does not have the +24V connected on the PCB.

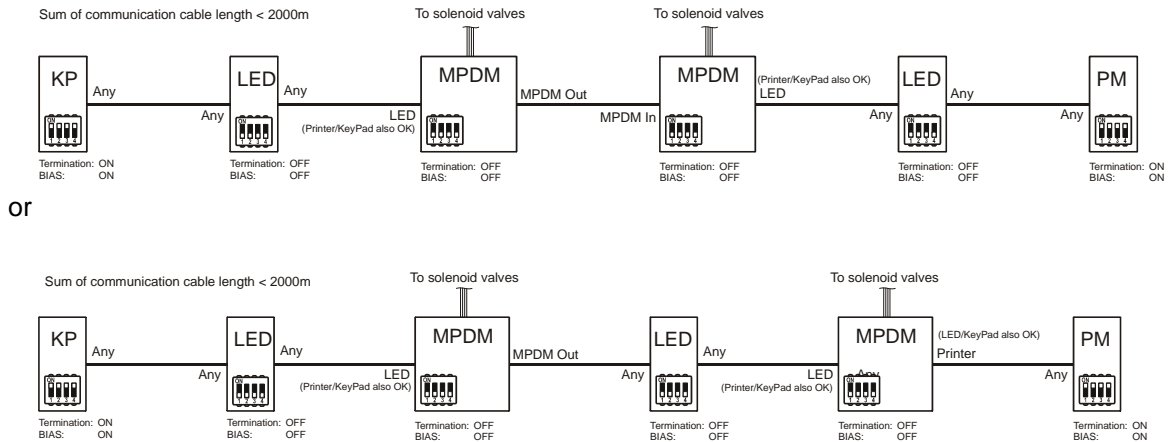

2.5.4. PC based system with 2 active and 6 passive modules

To make a PC based system a SIO (PC-interface) is needed. The SIO has 2 Lines (Synergy Channels) and normally only one of them are used, even if the SIO is placed in within the loop and not at one of the ends.

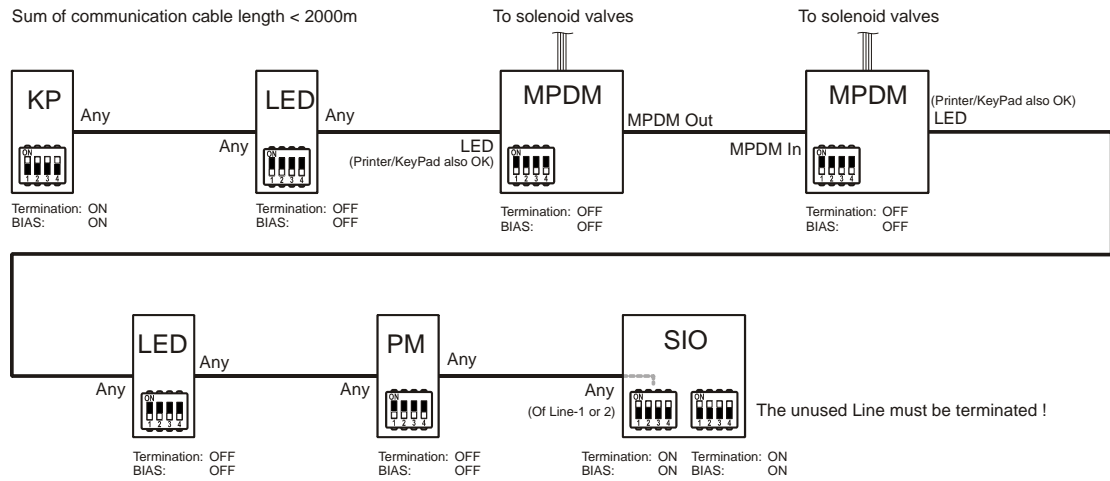

Alternative

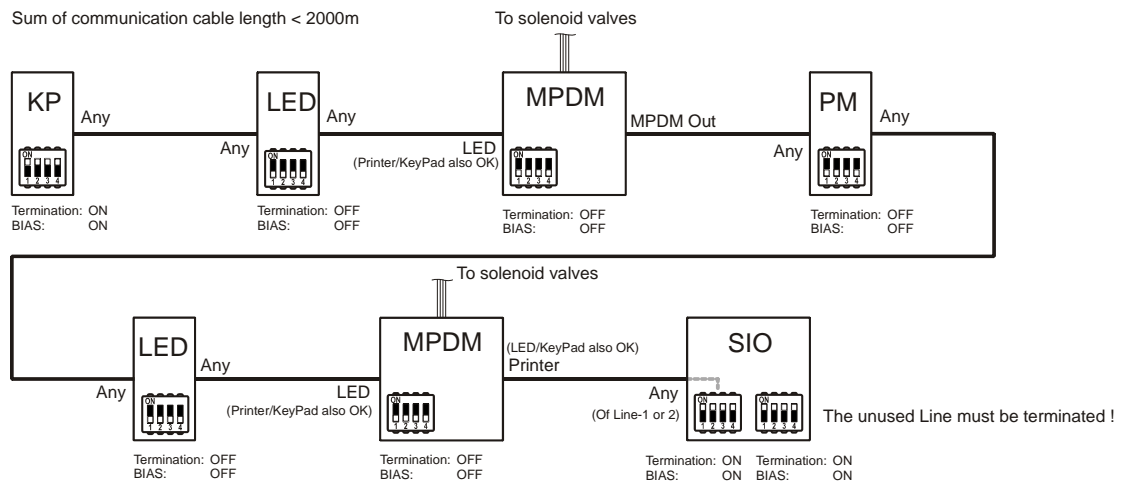

Within the loop.

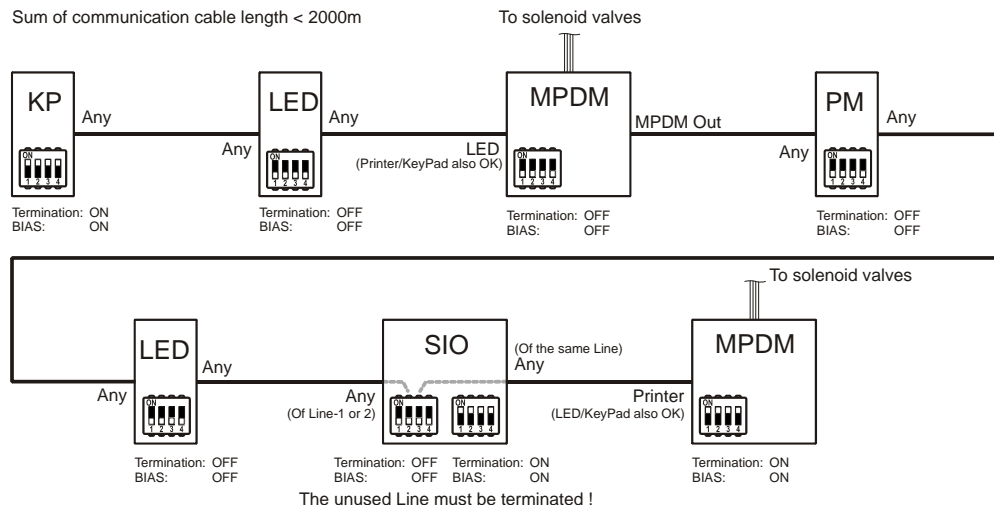

2.5.5. How to connect two already powered passive modules

For some installations it may be needed to connect two passive module that are already powered from other sources. This can be done by not connecting the +24V (Red) cable.

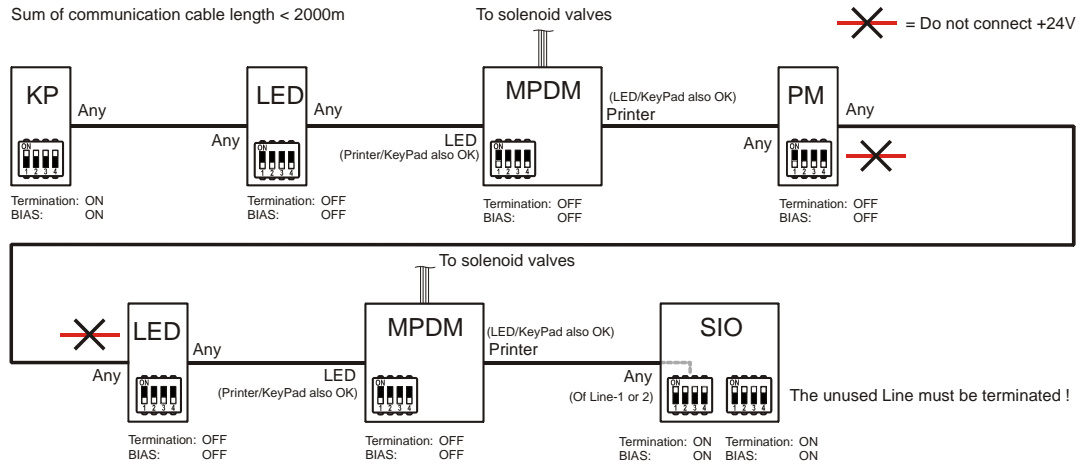

2.5.6. How to use the SIO as line amplifier.

If more than 2000 meters of communication cable is needed the SIO (PC-interface 23403) can be used as a “Line-amplifier”.

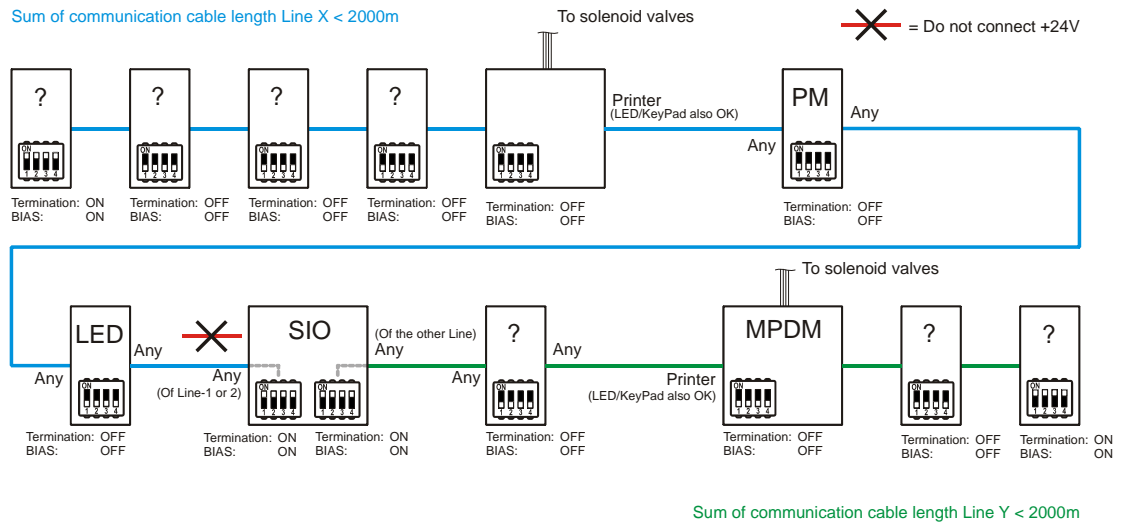

2.6. Drop-Downs (not recommended).

Sometimes you may want to quickly hook up some module in an existing Synergy communication loop. The recommended way is to hook it up within the loop but if this is not possible or if it is a temporary solution the module can be hooked up as a so-called “Drop-Down” see figure.

A “Drop-Down” is always bad for a current loop because it then becomes more of a voltage loop and will be

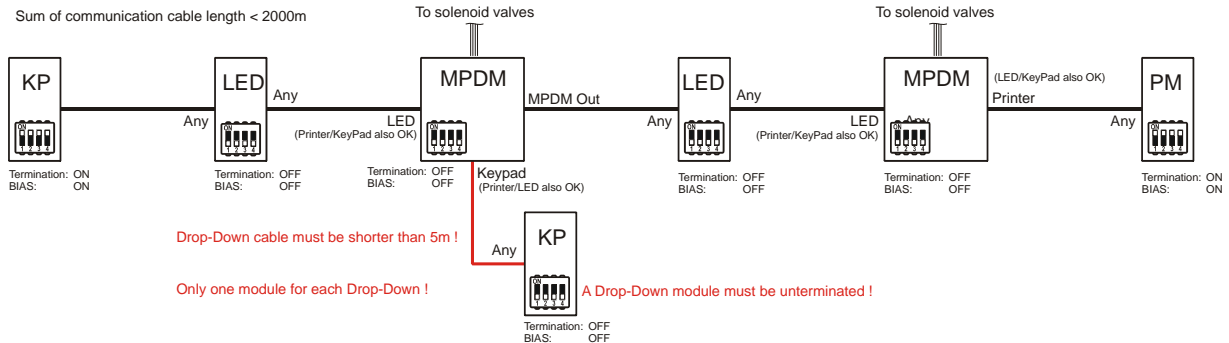

easier to disturb.

The more “Drop-Downs” that are added and the longer the cables are they the more the communication loop will become an antenna.

In small systems it is not recommended but it is possible to have some “Drop-Downs”.

We strongly recommend not using “Drop-Downs” in larger systems.

If a “Drop-Down” for some reason is needed this are the rules.

“Drop-Down” cable must not be longer than 5 meters !

“Drop-Down” module must be unterminated !

Only one module per “Drop-Down” !

As few “Drop-Downs” in a system as possible !

3. Electric connection of solenoid valves and meters

Electric connection of solenoid valves and meters

A, B and **Gnd** of the MPDM port is connected to **A, B** and **Com** of the meter.

+24 V of the MPDM port is connected to **o** of the meter. **Sol** of the MPDM port is connected to the unmarked connector of the meter. The solenoid valve is also connected to these two connectors of the meter.

The meter 24 728 is equipped with a light valve symbol which indicates if the valve is opened or not. (Solenoid voltage).

Normally a four lead cable is used but if two pulse trains is used the cable should have five leads. The area of each lead should be at least 0,5 mm². Balcrank recommends a multi thread cable.

If the Balcrank cable 23 393 is used colours should be used as below to simplify support.

Brown +24V

Yellow Sol

White A

Grey B, (if meter 24738 and cable 23412 is used, remember to check “Use 2-signal meter”)

Green GND.

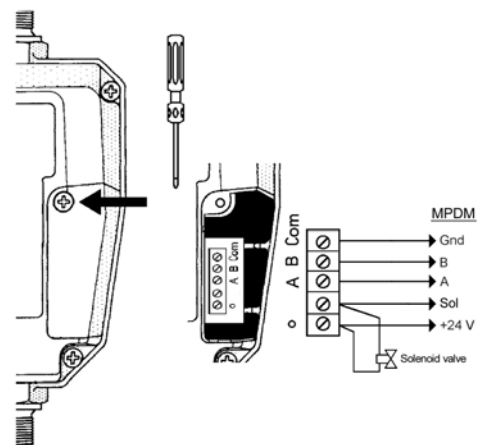

This simplifies support considerably.

OBS! To obtain a secure function the cable length between solenoid valve, meter and MPDM should maximum 10 m. Cable resistance affects the solenoid valve current and cable impedance affects the meter signals.

4. Electric connection non standard

The way off electric connections described in chapters 1, 2 and 3 is founded on basic rules of electricity, data for the used components and international standards. Balcrank leaves no warranty and take no responsibility if this altered.

4.1. General

The Synergy system is designed to work without problems even if there is external interference. Because of this the system can, under normal circumstances, handle smaller side steps from the standard installation.

4.2. Communication-loop

A basic rule is that the longer the loop is and the more modules connected to the loop the more important it gets to have a correctly installed system with correct termination and bias.

If the system is "small" and mostly follows the standards it will with great possibility work even with side steps from the rule maximum 5 m for "drop-downs". Basically even a "drop-downs" of 5 m is a side step but Balcrank has tested and verified this to work.

4.3. Solenoid valves

The reason for stating maximum cable length between MPDM and solenoid valve to 10 m is the cable resistance. According to Ohms law, the voltage drop over a cable is proportional to the resistance of the cable. The result of this is that if the cable resistance is to high the voltage over the solenoid valve will not be high enough to give the current needed to open the valve.

If more than 10 m of cable is needed this can be done using a cable with larger lead area. To simplify this, the thicker cable can be used from the MPDM to a connection box close to the valve and the standard cable between the connection box and the valve. If the length of the cable does not exceed the 10 m too much the standard cable can possibly be successfully used.

4.4. Meters

The reason for stating maximum cable length between MPDM and solenoid valve to 10 m is the cable impedance (resistance for alternating current) and inductance. The MPDMs ability to detect pulses is dependant of the level and the shape of the pulses. Large cable impedance lowers the level and flattens the flanks (the shape of the pulse). Because this is not a current loop, the pulses can also be affected by magnetic fields in the environment through the inductance of the cable (It works as a coil). By using a larger lead area, avoiding placing the cable close to AC cables with high currents or large electric motors it is possible to use more than 10 m of cable.

5. Mechanical installation

The foundation for a well operating and none leaking system is being thorough when installing. Use pipes, couplings, valves and meters suitable for the intended fluid and the pressure in the system. A filter of adequate cleaning capability for the filled object should always be used at the outlet of the pump. The filter should be equipped with an indicator. Hoses should always be used between movable components and the pipe works, such as pumps, hose reels and so on.

5.1. Pipe work

Cleanliness is of great importance when installing pipe work for volume-controlled systems for fluid distribution both at installation point and when storing components before installation. If contamination enters the system this can cause severe operational disturbances both to the filled object and to the distribution system. Use pipes intended for hydraulic systems and correct pressure according to the pump used. Liquid sealant or "rubber-steel" washers should be used to seal joints. Attach the pipes to the "wall" thoroughly. Check the system for leaks regularly and tighten couplings if needed.

- OBS!** Always use a pressure relief valve to avoid harmful pressure caused by temperature variations of the environment.
- OBS!** Never use Teflon tape or textile as sealant because this is unfit for this kind of systems.

5.2. Solenoid valves

A shut-off valve and a strainer (200 micron) should always be used between the pipe work and a solenoid valve as shown in figure to the right. The figure shows an example for oil. To prevent initial damage to the solenoid valve the pipe work should be flushed before the solenoid valve is installed. If the valve has to be installed prior to flushing its internal parts can be removed during flushing. Do not forget to put them back properly.

OBS! A hose must always be used at least one side of the meter to prevent tensions caused by movements.

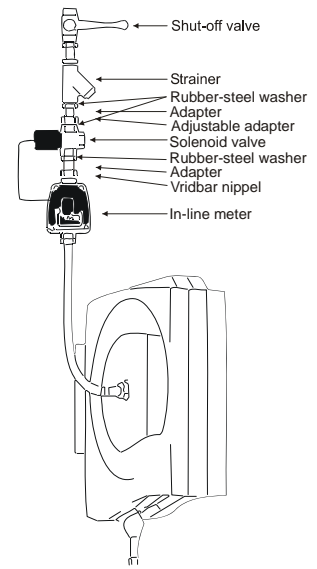

5.3. Meters

The meter is of great importance for the accuracy of the system. To prevent initial damage to the meter the pipe work should be flushed before the meter is installed.

OBS! If the meter not should be approved or being a part of an approved system the meter can be installed in any direction. In this case the IN and OUT marking of the meter is of no concern.

6. Modules

6.1. In general

Synergy hardware modules can be divided into 3 categories.

Active modules: All modules that have its own power supply is in this category. By default MPDM (23400), TCM (23408) and TSM (23430) are active modules.

Passive modules: Modules that does not have its own power supply like KP (23401), GKP (23410), PM (23402), LED (23404) and SIO (23403) belongs to this category.

The LED (23404) can be supplied with a power supply and will then be an active module.

Add-On modules: This module can be added to a standard module for example CM (23405).

All active and passive module PCBs is fitted with one or more four pole connectors labelled **A**, **B**, **+24V** and **Gnd**. These four poles are used for the communication in the system. All modules have a **RESET**-button and one or more status LEDs.

The MPDM has the capacity to supply other modules such as LED, KP, PM and SIO with power as long as the total current including solenoid valves is below 5A. If there is a risk of exceeding 5 A an external power supply can be used, the SIO and the PM is prepared for this.

If additional MPDMs are connected, it is important that their +24 VDCs are not connected to each other. To simplify this, the MPDM is fitted with two communication ports labelled MPDM IN and MPDM OUT. The +24 VDC is not connected on these two ports.

OBS! A communication cable between a module within the "terminated loop" and a module outside the "terminated loop" ("drop-down") must be shorter than 5 meter. A current loop is dependant of being a loop not a tree. The longer the loop is and the more modules there are the more important.

6.2. MPDM module (23 400)

The MPDM module is described thoroughly in its own manual.

6.2.1. Mechanical installation

The MPDM is mounted on a wall or similar using the four ø5 mm wholes at the bottom of its casing.

6.2.2. Electric installation



The power supply should be connected to mains 230 V AC in a proper way following valid rules.

Balcrank recommends that the connection is done through a 2-pole working switch.

The PCB has five connectors (A) to which other modules can be connected. They are labelled MPDM Out, MPDM IN, KeyPad, Printer and LED. Arrow (B) shows the position of the RESET-button. 24 VDC power supply is connected at (C) on the PCB. The module can be set in OFF or OVERRIDE-mode by a key-switch (explained in *USER GUIDE*). The key-switch is connected to the connector at (D). (E) Shows the four ports for the solenoid valves and the meters. (G) is a indicator for open solenoid valve and (F) indicates incoming pulses. (U) indicates if processor is running or not. (I) is the termination and biasing DIL-switch. The communication driver is shown at (J). By removing the jumper marked (K) the current calibration is locked.

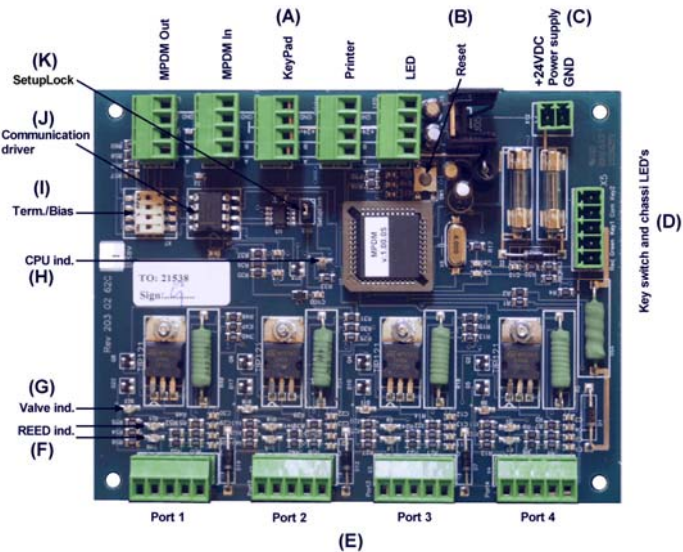

6.2.3. Technical specifications

- Net ports:** 5 Synergy ports (A) for data communication, 2 without +24VDC.
- Meter inputs:** 4 (E) 32 bit for one or two pulse signals. Switch or active signal max 50 V. Supports flow direction and phase error detection.
- Control outputs:** 4 (E) for solenoid 24 VDC max 1,25 A. Closes after about 30 s when short circuited, this is logged in the database.
- Other:** RISC-based microprocessor
EEPROM, 64 KB.
Connector (D) for 3-pos key switch. Connector (C) for 24 VDC 5A power supply.
- Power supply:** Primary 230 VAC 500mA
Secondary 24 VDC 5 A
- Max current:** 500 mA + 4x1.25 A for solenoid valves
- Casing:** Strong black powder painted steel box
- Outer measures:** 303 x 228 x 65 mm.
- Fitting:** 4 x ø5mm
CC = 250 x 175 mm
- Weight:** 3,9 kg

6.3. KP module (23 401)

6.3.1. Mechanical installation

The KP is mounted on a wall or similar using the two ø5 mm wholes at the bottom of its casing.

It is possible to mount the lid with the keys and display in two ways, with the display window either in the deep end or the shallow end. There are two “Knock-Out” cable inlets Ø16mm in both of the short sides of the box. Other cable inlets can be drilled in either the short sides or in the bottom of the box.

NOTE! When the display window is placed towards the deep side of the box it is possible to let a cable in at both of the short sides of the box.

NOTE! When the display window is placed towards the shallow side of the box it is only possible to let a cable in at the deep side of the box if the PCB is 203 02 65 A or B.

6.3.2. Electrical installation

(A) is the communication driver. The led (B) indicates is the processor is running or not. The contrast angle of the display can be adjusted by turning the screw at (C). Position (D) shows the position of the RESET-button. The KP is fitted with two connectors (E) used for the communication loop labelled **A, B, +24V** and **GND**. Follow the cable recommendation.

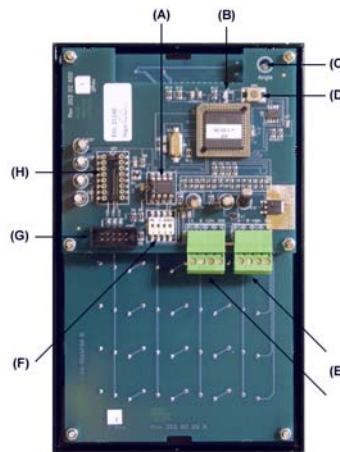

2 board type (older)

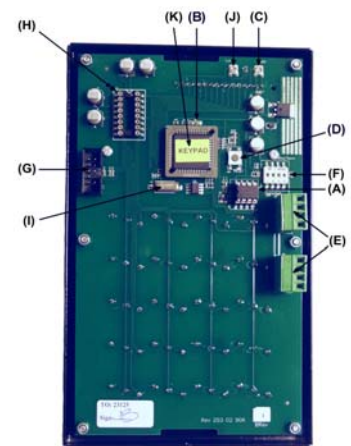

Single board type (Current)

(F) is the termination and biasing DIL-switch. The connector for the serial port is located at (G). The serial port driver chip should be inserted at (H).

6.3.3. Technical specifications

Net ports: 2 pieces of Synergy ports (E) for data-communication.

Connector: 1 piece of connector to connect the KeyPad CPU PCB to the button and LCD PCB.
1 piece of 10-pole connector (G) for the serial port, newer models. Part number 23 415 is needed to have a DSUB 9-pin serial port (RS-232) on the KeyPad.

LCD display: 2x16 signs with backlight.

Keyboard: 20 buttons covered with polycarbonate plastic overlay.

Other: RISC-based microprocessor
EEPROM, 64KB.

Casing: Strong black powder painted steel box.

Power supply: 24 VDC through communication cable.

Max current: 100 mA

Outer measures: 113 x 188 x 62 mm.

Mounting: 4 x \varnothing 5 mm
CC = 68 x 140 mm

Weight: 1,2 kg

6.4. PM module (23 402)

6.4.1. Mechanical installation

The PM is mounted on a wall or similar using the four $\varnothing 5$ mm wholes at the bottom of its casing. The connector for the printer cable should be downwards. The PM has 2 "knock-out" $\varnothing 18.5$ mm wholes on three sides for cables. If the PM should be placed in an office and the Synergy system should be connected to a PC computer it is possible to mount a SIO in the same box.

6.4.2. Electric installation

The PM has two connectors (A) for data communication labelled **A**, **B**, **+24V** and **GND**. Follow the cable recommendation. If the PM is far away from any it can be fitted with a chassis connector for

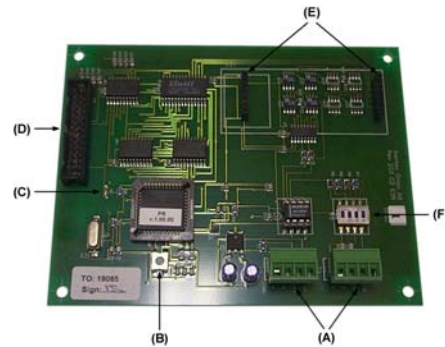

external power supply. Then the +24VDC from the communication loop should not be connected. Position (B) shows the position of the RESET-button.

6.4.3. Technical specifications

Net ports:	2 pieces of Synergy ports (A) for data-communication.
Out ports:	1 piece (D) CENTRONIC for a parallel printer.
Other:	RISC-based microprocessor EEPROM, 64 KB.
Supply voltage:	24 VAC
Max current:	100 mA
Casing:	Strong black powder painted steel box
Outer measures:	23 x 195 x 55 mm.
Mounting:	4 x $\varnothing 5$ mm CC = 175 x 140 mm
Weight:	1,6 kg (mounted in steel box)

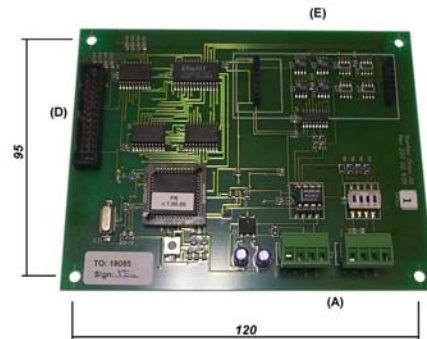

6.5. SIO module (23 403)

6.5.1. Mechanical installation

The SIO is mounted on a wall or similar using the four $\varnothing 5$ mm wholes at the bottom of its casing. The connector for the serial cable should be downwards. The SIO has 2 "knock-out" $\varnothing 18.5$ mm wholes on three sides for cables. If the SIO should be placed in an office and there is need for a printer it is possible to mount a PM in the same box.

6.5.2. Electric installation

The SIO has four connectors (A) for data communication labelled **A**, **B**, **+24V** and **GND**. Follow the cable recommendation. If the SIO is far away from any it can be fitted with a chassis connector for

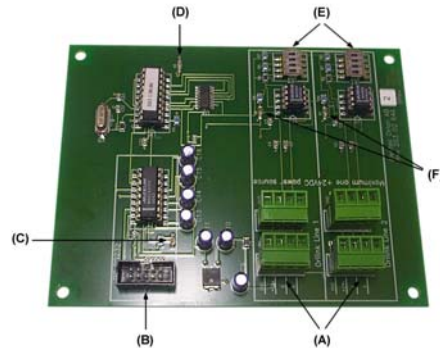

external power supply. Then the +24VDC from the communication loop should not be connected.

The SIO has a RS-232 port (10 pole) where a PC computer can be connected using the 10-pole 9-pole DSUB chassis adapter cable

6.5.3. Technical specifications

- Net ports:** 4 Synergy ports (A) for data communication.
- Out ports:** 1 RS-232 port (B) for communication with a PC
- Other:** RISC-based microprocessor
- Supply voltage:** 24 VDC through com.-loop or external
- Max current:** 100 mA
- Casing:** **Strong black powder painted steel box.**
- Outer measures:** 230 x 195 x 55 mm.
- Mounting:** 4 $\varnothing 5$ mm
CC = 175 x 140 mm
- Weight:** 1,7 kg (mounted in steel box)

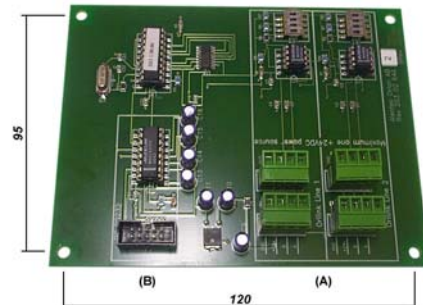

6.6. LED module (23 404)

6.6.1. Mechanical installation

The LED is mounted on a wall or similar either by drilling four holes at the bottom of its casing or by using the by packed bracket. Cable wholes are drilled at suitable points.

6.6.2. Electric installation

The LED is equipped with a port (A) for connecting a solenoid valve and a meter. This enables the LED to act as a stand-alone dispensing unit with 16 adjustable preset volumes. Position (B) shows LEDs for detecting incoming pulses. A clock module (CM, 23405) can be inserted at (C). The DIL-switch (D) is used to set Current model Older model



the operation mode. Push buttons to control the LED in stand-alone mode should be connected to connector (E). The led (F) indicates if the processor is running or not. It has two connectors (G) for data communication labelled **A**, **B**, **+24V** and **GND**. Follow the cable recommendation. (H) is the communication driver. The termination and biasing DIL-switch can be found at (I). Position (J) shows the position of the RESET-button.

6.6.3. Technical specifications

- Net ports:** 2 Synergy ports (G) for data communication.
- Meter input:** 1 pcs (A) 32 bit for one or two pulse trains. Switch or active signal max 50 V. Can detect flow direction and phase errors.
- Control input:** 1 10-pin connector for push buttons (E).
- Control output:** 1 (A) for solenoid valve 24 VDC max 1,25 A.
- Display:** 5 + 3 red LED based figures with moveable decimal point. Main figures are 40 mm high and support figures 15mm high. Also supports time “:.” and valve open symbol.
- Other:** RISC-based microprocessor
EEPROM, 64KB.
Port for real-time clock (F)
- Casing:** Black painted steel with polyester plastic overlay with integrated smoked glass.
- Max current:** 250 mA
- Outer measures:** 200 x 121 x 90 mm.
- Mounting:** 4 ø4.3 mm CC = 88,5 x 188,5 mm or
2 ø5.8 mm, CC = 62,5 mm with mounting bracket.
- Weight:** 0,8 kg

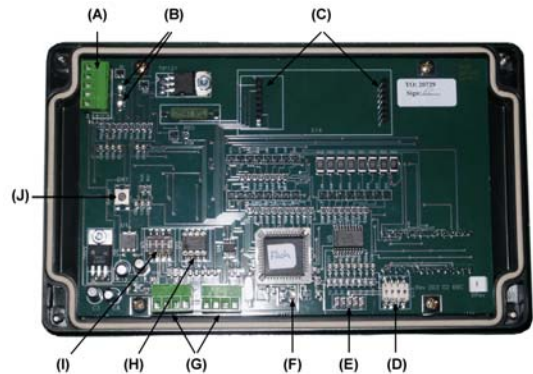

6.7. CM module (23 405)

6.7.1. Installation

The module is installed with the mountings on the bottom. It can be installed on all modules with the corresponding connector, for instance a LED or a PM. Make sure all pegs are aligned before pressing the module in place. Pegs can be bent gently to make alignment easier.

NOTE! Only one CM can be used in a system

6.7.2. Technical specifications

- Connector:** 2 pieces 7-pole pin connector (A).
- Other:** Real time clock with battery backup
- Life time:** At least 10 years from manufacturing date of the chip.
- Weight:** 12 g

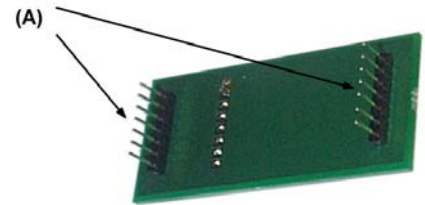

6.8. TCM module (23 408) / TSM module (23430)

The TCM module is described thoroughly in its own manual. The TCM can only be used for waste oil pump control without PC. With a PC it can be used for booth fresh and waste oil control.

6.8.1. Mechanical installation

The TCM is mounted on a wall or similar using the four ø5 mm wholes at the bottom of its casing.

6.8.2. Electric installation



The power supply should be connected to mains 230 V AC in a proper way following valid rules.

Balcrank recommends that the connection is done through a 2-pole working switch.

The PCB has five connectors (A) to which other modules can be connected. They are labelled MPDM Out, MPDM IN, Keypad, Printer and LED. Arrow (B) shows the position of the RESET-button. 24 VDC power supply is connected at (C) on the PCB. The module can be set in On-Line, OFF or OVERRIDE-mode by a key-switch (explained in *USER GUIDE*). The key-switch is connected to the connector at (D). (E) Shows the four ports for the solenoid valves and discrete level sensors. (G) is a indicator for open solenoid valve and (F) indicates status of the discrete sensor. (H) indicates if processor is running or not. (I) is the termination and biasing DIL-switch. The communication driver is shown at (J). The jumper marked (K) has no effect on a TCM.

(L) indicates if an analogue sensor is connected or not and if a connected sensor is OK or not. Each of the four ports also have a 2-pole connector (M) for an analogue level sensor.

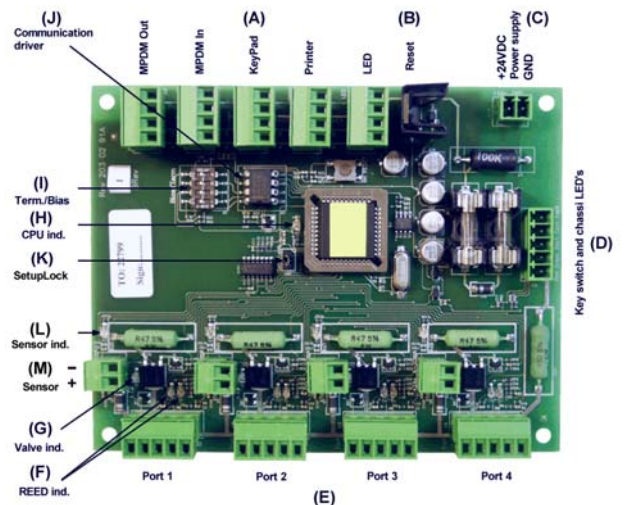

6.8.3. Technical specifications

- Net ports:** 5 Synergy ports (A) for data communication, 2 without +24VDC.
- Sensor inputs:** 4 (E) dual High/Low digital inputs. Switch or active signal max 50 V. Supports individual change of Active high/ Active low.
- 4 (M) 4-20mA/24VDC analogue sensor inputs with 10-bit (1024 steps) A/D-converter. 0-24 are used for sensor check and remaining 1000 are used for measured parameter.
- Control outputs:** 4 (E) for solenoid 24 VDC max 1,25 A. Closes after about 30 s when short circuited, this is logged in the database.
- Other:** RISC-based microprocessor
EEPROM, 64 KB.
Connector (D) for 3-pos key switch. Connector (C) for 24 VDC 5A power supply.
- Power supply:** Primary 230 VAC 500mA
Secondary 24 VDC 5 A
- Max current:** 500 mA + 4x1.25 A for solenoid valves
- Casing:** Strong black powder painted steel box. TSM (23430) has 12 indication LEDs and a LED test button in the lid.
- Outer measures:** 303 x 228 x 65 mm.
- Fitting:** 4 x ø5mm
CC = 250 x 175 mm
- Weight:** 3,9 kg

6.9. GKP module (23 401)

6.9.1. Mechanical installation

The GKP is mounted on a wall or similar using the two ø5 mm wholes at the bottom of its casing.

It is possible to mount the lid with the keys and display in two ways, with the display window either in the deep end or the shallow end. There are two “Knock-Out” cable inlets Ø16mm in both of the short sides of the box. Other cable inlets can be drilled in either the short sides or in the bottom of the box.

6.9.2. Electrical installation

(A) is the communication driver. The led (B) indicates is the processor is running or not. The contrast angle of the display can be adjusted by turning the screw at (C). Position (D) shows the position of the RESET-button. The KP is fitted with two connectors (E) used for the communication loop labelled **A**, **B**, **+24V** and **GND**. Follow the cable recommendation.

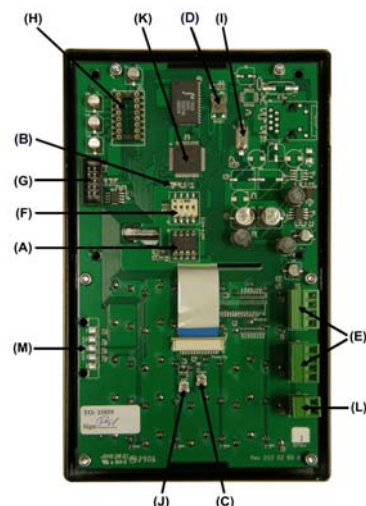

(F) is the termination and biasing DIL-switch. The connector for the serial port is located at (G). The serial port driver chip should be inserted at (H). (L) can be used to supply the keypad with external power or get +24VDC to feed for example a reader of some kind. The graphic keypad has a soldered microcontroller that cannot be replaced and because of this (M) can be used if a total reprogramming is needed.

6.9.3. Technical specifications

Net ports:	2 pieces of Synergy ports (E) for data-communication.
Connector:	1 piece of connector to connect the KeyPad CPU PCB to the button and LCD PCB. 1 piece of 10-pole connector (G) for the serial port, newer models. Part number 23 415 is needed to have a DSUB 9-pin serial port (RS-232) on the KeyPad.
LCD display:	Black and white graphic 350x240 dots with backlight.
Keyboard:	20 buttons covered with polycarbonate plastic overlay.
Other:	RISC-based microprocessor EEPROM, 64KB.
Casing:	Strong black powder painted steel box.
Power supply:	24 VDC through communication cable.
Max current:	100 mA
Outer measures:	113 x 188 x 62 mm.
Mounting:	4 x ø5 mm CC = 68 x 140 mm
Weight:	1,2 kg

7. Configuration

A Synergy configuration sheet **should** always be filled or altered during the configuration.

NOTE! To obtain technical support a copy of the configuration sheet for the complete installation must be sent to Balcrank at

**Balcrank
115 Reems Creek Rd.
Weaverville, NC 28787**

7.1. Check before configuration

Check that the module is working and communicating with the system according to the Synergy *Manual* chapter *Testing modules*.

NOTE! Do not forget to check and adjust the termination and BIAS according to Synergy Manual.

7.2. Addressing the MPDM

A new module has a default address when delivered such as MPDM 1000, PM 2000, KP 3000, LED 4000 and so on. To set an address for a new module or a module with unknown address press and hold it's RESET button for 5 seconds to set a temporary address. Immediately enter set-up mode from a KP and type 0 and then ENTER to get to the Main menu of the module, see below.

NOTE! Only one new module can be installed at a time. If you press the RESET-button on several terminals simultaneously or in a sequence, only the most recently pressed will be active.

TIP! Follow preferably "Recommendation for setting new addresses" when setting addresses.

7.3. Set-Up mode

Type the word "SETUP" on a KeYPad and press **ENTER**.
Type the **password** and press **ENTER**.

Type the address for the module that is to be configured and press **ENTER** to access its main menu. It is possible to add the 4-digit menu code to go directly to the desired menu.

```
Reel:SETUP      ‡
EXIT STOP CE ENT
```

```
PASS:_          ‡
Skriv Lösenord
```

```
Addr:X???_     ‡
Address[code]
```

```
XX:            ‡
XX MainMenu
```

Scroll through the module sub menus by pressing ↑ or ↓. When the desired menu is shown press ENTER etc.

7.4. Set address [XX//Addr]

Enter menu [XX//Addr] by pressing **ENTER**.

Press **ENTER** to get the cursor.

Type in the **desired address** and acknowledge by pressing **ENTER**.
When the cursor disappears it is finished.

Press **EXIT** two times to leave Set-Up mode.

```
XX:            ‡
XX MainMenu
```

```
Addr:X???     ‡
Set Address X???
```

```
Addr:X???_   ‡
Set Address X???
```

```
Addr:X???     ‡
Set Address X???
```

NOTE! If two or more modules have the same address, the system will fail. One of the modules has to be re-addressed.

TIP! Follow preferably "Recommendation for setting addresses" when setting addresses.

7.5. Recommendation for setting addresses

Each module demands a unique 16 bit hexadecimal address. There are some forbidden and some reserved addresses but it is possible to use all addresses between 0001 and 9999. To make it easier to upgrade and support the system we recommend using the chart to the right.

All modules are delivered from stock with the address set to the first recommended, MPDM-1000, PM-2000, KP-3000, LED-4000 and TCM-8000.

To make it easier for adding modules in the future it is recommended to have the first address set to XXX1. That is the first MPDM should have the address 1001 and the next one 1002 etc.

<u>Address</u>	<u>Module</u>
0000 – 0xxx	Forbidden
1000 – 1xxx	MPDM
2000 – 2xxx	PM
2999	PC-database
3000 – 3xxx	KeYPad
4000 – 4xxx	LED-display
5000 – 5xxx	Reserved
6000 – 6xxx	Reserved
7000 – 7xxx	Reserved
8000 – 8xxx	TCM
9000 – 9xxx	Reserved
A000 – FFFF	Forbidden

NOTE! It is essential to add modules to the configuration sheet continuously as they are configured to avoid collisions.

NOTE! Address 0000 is forbidden and addresses above 9999 are reserved for the system.

8. Using a terminal (KeYPad)

The terminal has a keyboard with multi-function buttons. Numbers 0-9, left and right button, STOP, EXIT, CE, ENTER and dot (.) are marked in **white letters**, these can be reached **directly**.

The alphabet is reached by first pressing **blue** ↑, **yellow** ↓ or **yellow** ↓ **two times**. **Do not keep and hold the arrow-button**. Type "blue letters" by first pressing **blue** ↑ and then **the button with the desired letter**. Type yellow letters in the same way, first press **yellow** ↓ and then **the button with the desired letter**. Some buttons have two yellow letters [Ö Ø Æ Å], to type the lower letter, press **yellow** ↓ **two times** and then **the button with the letter**. The currently active letter is shown in the upper right corner of the display.

NOTE! Letters can be used in ID-codes, Job numbers and passwords.

By pressing **EXIT**, you return without doing additional changes. By pressing an identification string follow by **STOP** you abort the active event. **CE clears** an entered value. Confirm changes or entries with the **ENTER** button.

9. Setting date and time

If the system is equipped with a real-time Clock Module (CM), this can be set using a Key Pad.

9.1. Set [CLOCK/Date] and [CLOCK/Time].

Type the word "CLOCK" using the Key Pad and press **ENTER**.

```
Reel:CLOCK_  ‡
EXIT STOP CE ENT
```

Current system date is displayed. Press **ENTER** to set a new date or ↓ and **ENTER** to set the time.

```
Date:01.11.28  ‡
FORMAT YY.MM.DD
```

With the cursor visible type the new date or time and finish with **ENTER**.

```
Date:01.11.28  ‡
FORMAT YY.MM.DD
```

When the cursor disappears the new setting is complete.

```
Time:09.30.25  ‡
FORMAT HH.MM.SS
```

NOTE! Do not forget punctuation between HH.MM.SS/YY.MM.DD !

```
Time:09.30.25  ‡
FORMAT HH.MM.SS
```

Press EXIT twice to exit configuration.

NOTE! It may take up to five minutes before all modules are updated since synchronization occurs every 10 minutes.

10. Fast menu codes

With a PC, the Synergy WinTools software and a SIO, you can customise the quick menu that appear when you press "?". To do this, assign a name to the menu, a module address and then a code. Password is optional. This code can also be used together with the address after you have typed SETUP followed by the password.

For a PM-module it will look like this,

Add user 20000260 YYYYY where YYYYY=password

Part	Function	Addresses	Code	Notes
MPDM				
<i>Main Menu</i>	Set address		0800	
	Change Sphere		0801	
<i>Ports</i>	Set Reel number		0X00	Where X is Port number
	Set Group		0X01	Where X is Port number
	Set Mask		0X02	Where X is Port number
	Set Time-Out		0X04	Where X is Port number
	Set Min Volume		0X05	Where X is Port number
	Set Max Volume		0X06	Where X is Port number
	Set Database Address		0X07	Where X is Port number
	Set LED Address		0X08	Where X is Port number
	Set Tank number		0X09	Where X is Port number
<i>Dispense Menu</i>	The set first dispense prompt		0X20	Where X is Port number
<i>User DB</i>	Delete User		0061	
	Add user		0062	
KP				
<i>Main Menu</i>	Set address		0800	
	Change Sphere		0801	
	Change Baud rate		0803	
LED				
<i>Main Menu</i>	Set address		0800	
	Change Sphere		0801	
<i>LED</i>	Set Visual time		0010	
	Change Mask		0011	
<i>Only Hardware 101</i>				
<i>Port</i>	Change Dispense point Nr.		0100	
	Change Group		0101	
	Change Mask		0102	
	Change Time-Out		0103	
	Change PPU		0104	
	Change Min Volume		0105	

	Change Max Volume		0106	
	Change DB address		0107	
	Change LED address		0108	Is always the module address
	Change Tank number		0109	
Chip soft LED10104RC16 or later				
Pre-Set	Change Pre-Set volume		004X	Where 0<= x <=F, 0 is Pre-Set 1 and F if Pre-Set 16
PM				
<i>Tank DB</i>	Set tank volume		28X3	Where X is Tank number
	Set Fluid name		28X2	Where X is Tank number
	Set reorder volume		28X4	Where X is Tank number
	Set stop volume		28X5	Where X is Tank number
	Print tank report		0224	
<i>User DB</i>	Add user		0260	
	Delete user		0261	
	Delete all users		0262	
<i>JOB-number DB</i>	Add JOB-number		0230	
	Delete JOB-number		0231	
	Delete all JOB-numbers		0232	
<i>Transaction DB</i>	Delete all transactions			
	Print transactions			
	Print all transactions		0220	
	Print by transaction		0221	
	Print by JOB-number		0222	
	Print by Employee		0223	
TCM				
<i>Main menu</i>	Change address		0800	
<i>Ports</i>	Change Tank No.		0X00	Where X is the port number
	Change Mask		0X01	Where X is the port number
Only for TCM with analogue sensor support (PCB 203 02 91 A and higher)				
	Change Time constant		0X02	Where X is the port number
	Change Offset		0X03	Where X is the port number
	Change Calibration		0X04	Where X is the port number
	Change Density of fluid		0X05	Where X is the port number
	Change Max volume of tank		0X06	Where X is the port number
	Change LED Address		0X07	Where X is the port number
	Change Name of Fluid		0X08	Where X is the port number
	Change Part number of fluid		0X09	Where X is the port number
	Change Sensor full scale		0X10	Where X is the port number
	Generate Volume array		0X11	Where X is the port number
	Shows current volume [L]		0X60	Where X is the port number
	Show sensor signal [%] &		0X61	Where X is the port number

	[mA] (Observe! -Does not always reflect the content of tank because it refers to the sensor max scale not the max volume of the tank.)			
	Change Tank area		0X62	Where X is the port number