

# Oil Piston Pumps PANTHER® HP 5:1 Pumps

The Panther® HP 5:1 ratio double acting pump is engineered for outstanding performance and reliability for dispensing lubricating oils and similar products up to SAE 90.

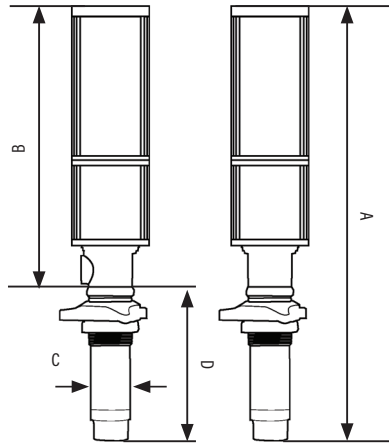

Dimensions inches (MM)			
1130-016 & 1130-021			
A	B	C	D
23.5" (523.9 mm)	14 3/8" (285 mm)	2 4/5" (71 mm)	6 1/2" (158.7 mm)
1130-018			
21 8/9" (555.6 mm)	14 3/8" (285 mm)	1 7/8" (47.6 mm)	7 1/2" (190.5 mm)

## TECHNICAL DATA

Operating air pressure	10-150 psi ( 0.7-10 bar)
Cycles per gallon	57 cyc/gal (15.06 cyc/liter)
Air consumption 100 psi (7 bar) & 4 gal/min (15 l/min)	24.80 SCFM
Max fluid stall pressure @150 psi (10 bar) <sup>(1)</sup>	760 psi (52 bar)
Effective air piston diameter	2.5" (63.5 mm)
Free Flow pump delivery with SAE 10W30 oil, 68° F (20° C), 100 psi (7 bar) air pressure	6 gal/min (30 l/min)
Air inlet	1/4" NPT(F)
Fluid inlet	1" NPT(F); 1 1/2" NPT(M)
Fluid outlet	1/2" NPT(F)
Wetted materials	Steel, Nickel Plated Steel, Stainless Steel, Aluminum, Ultrathane, Buna-N™, and Nylon
Service Bulletin	SB 1064

NOTE: Thermal expansion of the fluid in a distribution system can cause an increase in system pressure that can damage lubrication system components. Use pressure relief valve kit included with this pump.

(1) Ensure that all hose fittings and piping are rated for fluid outlet pressures. Balcrank recommends a minimum of 3x safety factor.

**Warning!** Do not use any Pride series products with flammable fluids.

Verify fluid compatibility with MSDS sheets.

Contact Balcrank for specific system design performance and technical data.

## Synthetic and Mineral Based Lubricants Hydraulic Fluid Transmission Fluid Gear Oil

Pride Series pumps are manufactured with a mechanical air valve and piston design which is more forgiving to environments with contaminated air. The 5:1 version is a medium pressure pump for supplying higher pressures and for longer pumping distances than the 3:1 version but at lower volume ideal for longer pumping distances and overall flow rates of 4 gpm.

### Applications

- Medium sized tank packages
- Medium volume maintenance shops
- Small car dealerships
- Quick lubes

**Pressure relief valve kit included with this pump.**

MODELS AVAILABLE	DESCRIPTION
<b>1130-016</b>	5:1 Bare carbon steel stub pump
<b>1130-018</b>	5:1 Bare carbon steel stub pump, flange mount
<b>1130-021</b>	5:1 Bare carbon steel pump with bung adapter

