

Oil Piston Pumps

TIGER® HP 6:1 Pumps

The Tiger® HP 6:1 ratio double acting pump is engineered for outstanding performance and reliability for dispensing lubricating oils and similar products up to SAE 90.

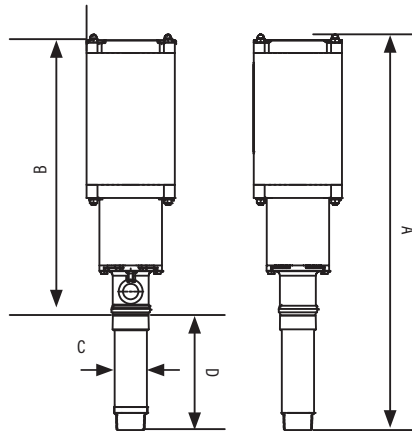

Dimensions inches (MM)			
A	B	C	D
21 5/7" (544.5 mm)	16 1/4" (412.9 mm)	2 1/8" (54 mm)	4" (101.6 mm)

Synthetic and Mineral Based Lubricants Hydraulic Fluid Transmission Fluid Gear Oil

Tiger® is the largest of the Pride series pumps. Pride series pumps are manufactured with a mechanical air valve and piston ring which is more forgiving of environments with contaminated air. The 6:1 version is a medium pressure pump for supplying higher pressures and longer pumping distances. The larger 3.2" air motor makes this pump ideal for larger users who need higher flow rates and slower pump cycle rates.

Applications

- Large sized tank packages
- Medium-large volume maintenance shops
- Medium to large volume car dealerships
- HD truck/fleet shops
- Off-road construction maintenance shops
- Mass-transit maintenance shops

Pressure relief valve kit included with this pump.

Windshield wash fluid & water based fluids for use with 1160-007 stainless steel model only.

TECHNICAL DATA	
Operating air pressure	40-150 psi (3-10 bar)
Cycles per gallon	31 cyc/gal (8.2 cyc/liter)
Air consumption 100 psi (7 bar) & 8 gal/min (30 l/min)	59 SCFM
Max fluid stall pressure @150 psi (10 bar) ⁽¹⁾	870 psi (60 bar)
Effective Air Piston Diameter	3.2" (81 mm)
Free flow pump delivery with SAE 10W30 oil, 68° F (20° C), 100 psi (7 bar) air pressure	16 gal/min (61 l/min)
Air inlet	3/8" NPT(F)
Fluid inlet	1" NPT(F); 1 1/2" NPT(M)
Fluid outlet	3/4" NPT(F)
Wetted materials 1130-019 - 1130-025 - 1130-026	Carbon steel, Buna-N™, Stainless steel, Ultrathane® and Aluminum
1160-007	Stainless Steel and Viton®
Service Bulletin	SB 1065

MODELS AVAILABLE	DESCRIPTION
1130-019	6:1 Bare carbon steel stub pump
1130-025	6:1 Bare carbon steel stub pump, flange mount
1130-026	6:1 Bare carbon steel stub pump with bung adapter
1160-007	6:1 Bare stainless steel stub pump

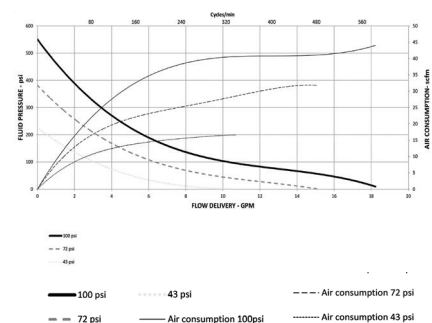

NOTE: Thermal expansion of the fluid in a distribution system can cause an increase in system pressure that can damage lubrication system components. Use pressure relief valve kit included with this pump.

(1) Ensure that all hose fittings and piping are rated for fluid outlet pressures. Balcrank recommends a minimum of 3x safety factor.

Warning! Do not use any Pride series products with flammable fluids.

Verify fluid compatibility with MSDS sheets.

Contact Balcrank for specific system design performance and technical data.