

# Oil Piston Pumps

## Lion™ 450 - 3:1 Pump

1

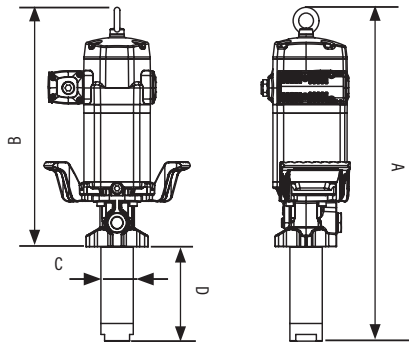

Dimensions inches (MM)			
A	B	C	D
27 7/8" (707 mm)	19 7/8" (505 mm)	3 35/64" (90 mm)	8 1/32" (204 mm)

## Synthetic and Mineral Based Lubricants Hydraulic Fluid Gear Oil Transmission Fluid

Medium pressure pump for oil systems where high volume dispensing using simultaneous dispense points is required. This pump is recommended for medium pumping distances.

### Applications

- Heavy duty truck/fleet
- Railroad/mass transit vehicle maintenance
- In-plant high volume transfer
- Marine
- Mining vehicle maintenance
- Large automotive dealerships

**Pressure relief valve kit included with this pump.**

**Wall or floor mount only. Pump OD does not fit 2" bung adapter. See pg. 32 for mounting bracket (4411-031).**

### TECHNICAL DATA

Operating air pressure	30 to 180 psi (2 to 12.4 bar)
Cycles per gallon	6
Air Consumption <sup>(1)</sup>	28 CFM (800 NI/min)
Max fluid outlet pressure <sup>(3)</sup>	510 psi (36 bar)
Air motor effective diameter	4.5" (115 mm)
Air motor stroke	4" (100 mm)
Delivery at 80 cpm	12 gal/min (45 l/min)
Max free flow delivery	32 gal/min (120 l/min)
Air inlet	1/2" NPT(F)
Fluid inlet	1 1/2" NPT(F)
Fluid outlet	3/4" NPT(F)
Wetted materials	Steel, Hard Chromed Steel, Zinc Plated Steel, Stainless Steel, Cast Iron, Polyurethane, Buna-N™, Bronze Filled PTFE
Noise level <sup>(2)</sup>	80 dB
Service Bulletin	SB 1134

- (1) Maximum air consumption with 75 psi (5 bar) air inlet pressure and 80 cpm.  
 (2) Maximum noise level measured at 3' (1 m) from the pump, 100 psi (7 bar) air pressure and free delivery.  
 (3) Ensure that all hose fittings and piping are rated for fluid outlet pressures. Balcrank recommends a minimum of 3x safety factor.

NOTE: Thermal expansion of the fluid in a distribution system can cause an increase in system pressure that can damage lubrication system components. Use pressure relief valve kit included with this pump.

**Warning!** Do not use any Lion™ 450/600 series products with flammable fluids.

Verify fluid compatibility with MSDS sheets.

Contact Balcrank for specific system design performance and technical data.

MODELS AVAILABLE	DESCRIPTION
<b>1430-001</b>	Lion™ 450 3:1 stub pump

### TEST FLUID: SAE 10

Cycles/min.

