

Oil Piston Pumps

Lion™ 600 - 12:1 Pump

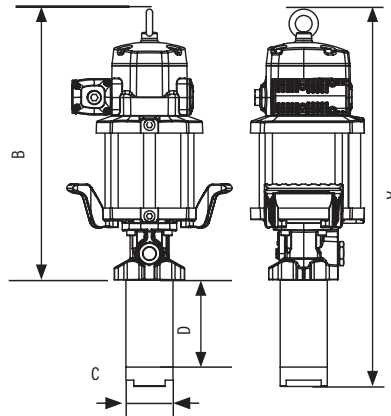

Dimensions inches (MM)			
A	B	C	D
28 1/4" (716 mm)	20 1/3" (516 mm)	2 3/4" (70 mm)	8" (200 mm)

Synthetic And Mineral Based Lubricants Hydraulic Fluid Gear Oil Transmission Fluid

High pressure pump and high-volume, can be used with simultaneous dispense points. This pump operates at slow cycle rates for large shops requiring long pumping distances applications or when cold weather or low air pressure could limit pump performance.

Applications

- Heavy duty truck/fleet
- Railroad/mass transit vehicle maintenance
- In-plant high volume transfer
- Marine
- Mining vehicle maintenance
- Large automotive dealerships

Pressure relief valve kit included with this pump.

Wall or floor mount only. Pump OD does not fit 2" bung adapter. See pg. 32 for mounting bracket (4411-031).

TECHNICAL DATA

Operating air pressure	30 to 180 psi (2 to 12.4 bar)
Cycles per gallon	11
Air Consumption ⁽¹⁾	41 CFM (1,150 NI/min)
Max fluid outlet pressure ⁽³⁾	2,040 psi (144 bar)
Air motor effective diameter	6" (150 mm)
Air motor stroke	4" (100 mm)
Delivery at 60 cpm	5 gal/min (20 l/min)
Max free flow delivery	17 gal/min (65 l/min)
Air inlet	1/2" NPT(F)
Fluid inlet	1 1/2" NPT(F)
Fluid outlet	3/4" NPT(F)
Wetted materials	Cast Iron, Hard Chromed Steel, Steel, Polyurethane, and Buna-N™
Noise level ⁽²⁾	80 dB
Service Bulletin	SB 1138

(1) Maximum air consumption with 75 psi (5 bar) air inlet pressure and 80 cpm.

(2) Maximum noise level measured at 3' (1 m) from the pump, 100 psi (7 bar) air pressure and free delivery.

(3) Ensure that all hose fittings and piping are rated for fluid outlet pressures. Balcrank recommends a minimum of 3x safety factor.

NOTE: Thermal expansion of the fluid in a distribution system can cause an increase in system pressure that can damage lubrication system components. Use pressure relief valve kit included with this pump.

Warning! Do not use any Lion™ 450/600 series products with flammable fluids.

Verify fluid compatibility with MSDS sheets.

Contact Balcrank for specific system design performance and technical data.

MODELS AVAILABLE

1430-006

DESCRIPTION

Lion™ 600 12:1 stub pump

TEST FLUID: SAE 10

Cycles/min

