

Used Fluid Equipment Evacuators



Overview

- Extract used oil and other fluids from any vehicle - safer, cleaner
 - No more stripped drain plugs
 - Great for cars, boats, motorcycles, and small engines
 - Easily remove overfills
 - Vacuum-charged unit is completely portable and easy to use
 - Includes six suction probes (metal and flexible)
 - Suction probes equipped with quick disconnect couplers
 - Adapters for BMW and Volkswagen included
 - Self-evacuating feature makes emptying clean and easy
 - Available version with clear bowl
- Capacity: 2 gal (7.5 l)

MODELS AVAILABLE	DESCRIPTION
<input type="checkbox"/> 4140-056	Oil Evacuators
<input type="checkbox"/> 4140-057	Oil Evacuators with Clear Domes and Mercedes Adapter

TECHNICAL DATA		
	4140-056	4140-057
Tank capacity	18.5 gal (64.35 l)	18.5 gal (64.35 l)
Max. draining capacity	70%	80%
Air pressure for vacuum	100 psi (7 bar)	100 psi (7 bar)
Depressurization time	2' 15"	2' 15"
Suction hose	6 1/2" (2m)	6 1/2" (2m)
Draining hose	5' (1.5 m)	5' (1.5 m)
Service Bulletin	SB 4081	SB 4082

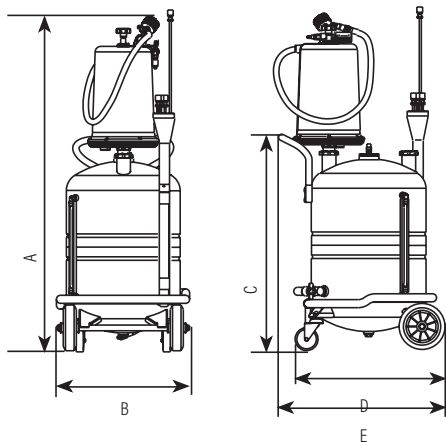

DIMENSIONS INCHES (MM)				
A	B	C	D	E
46.06" (1,170)	18.5" (470)	29.5" (750)	18.70" (475)	22.84" (580)