

Lion™ 600 - 6:1

Pumps
Piston

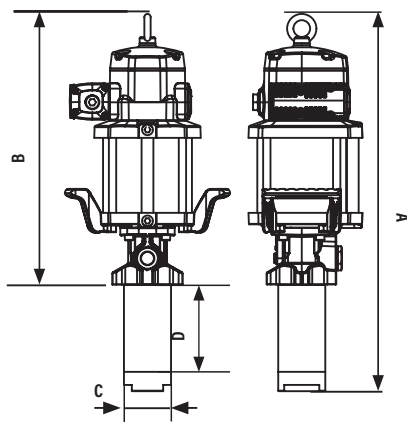

DIMENSIONS INCHES (MM)			
A	B	C	D
28 3/8" (721 mm)	20 23/64" (517 mm)	3 35/64" (90 mm)	8 1/32" (204 mm)

Fluids

- Synthetic and mineral based
- Lubricants
- Hydraulic fluid
- Gear oil
- Transmission fluid

Applications

- Heavy duty truck/fleet
- Railroad/mass transit vehicle maintenance
- In-plant high volume transfer
- Marine
- Mining vehicle maintenance
- Large automotive dealerships

TEST FLUID: SAE 10
Cycles/min

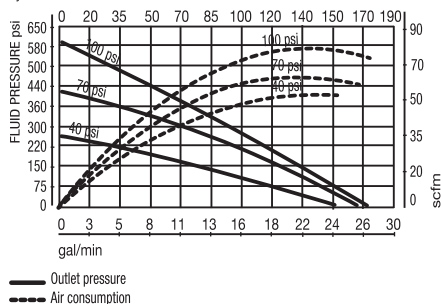

Overview

Lion™ 600 - 6:1 operates at slow cycle rates for high volume applications. Medium/high pressure pump for oil systems where high volume dispensing using simultaneous dispense points is required.

Medium/high pressure pump is recommended for longer pumping distances.

MODELS AVAILABLE	DESCRIPTION
1430-005	Lion™ 600 6:1 stub pump

TECHNICAL DATA	
Pump Ratio	6:1
Operating air pressure	30 to 175 psi (2 to 12 bar)
Cycles per gallon	6
Air Consumption ⁽¹⁾	39 cfm (1,100 l/min)
Max fluid outlet pressure ⁽³⁾	1,020 psi (72 bar)
Air motor effective diameter	6" (150 mm)
Air motor stroke	4" (100 mm)
Delivery at 60 cpm	9 gal/min (35 l/min)
Max free flow delivery @ 100 psi (7 bar)	26 gal/min (100 l/min)
Air inlet	1/2" NPT(F)
Fluid inlet	1 1/2" NPT(F)
Fluid outlet	3/4" NPT(F)
Wetted materials	Cast iron, aluminum, nickel, steel, polyurethane, Buna-N™ and zinc
Noise level ⁽²⁾	80 dB
Service Bulletin	SB 1137

(1) Maximum air consumption with 75 psi (5 bar) air inlet pressure and 60 cpm.

(2) Maximum noise level measured at 3' (1 m) from the pump, 100 psi (7 bar) air pressure and free delivery.
 (3) Ensure that all hose fittings and piping are rated for fluid outlet pressures. Balcrank recommends a minimum of 3 x safety factor.

NOTE: Thermal expansion of the fluid in a distribution system can cause an increase in system pressure that can damage lubrication system components. Use pressure relief valve kit included with this pump.

Warning! Do not use any Lion™ 450/600 series products with flammable fluids.

Verify fluid compatibility with MSDS sheets.

Contact Balcrank for specific system design performance and technical data.