

# Grease Inductor - Lion™ Inductor

Pumps  
Piston

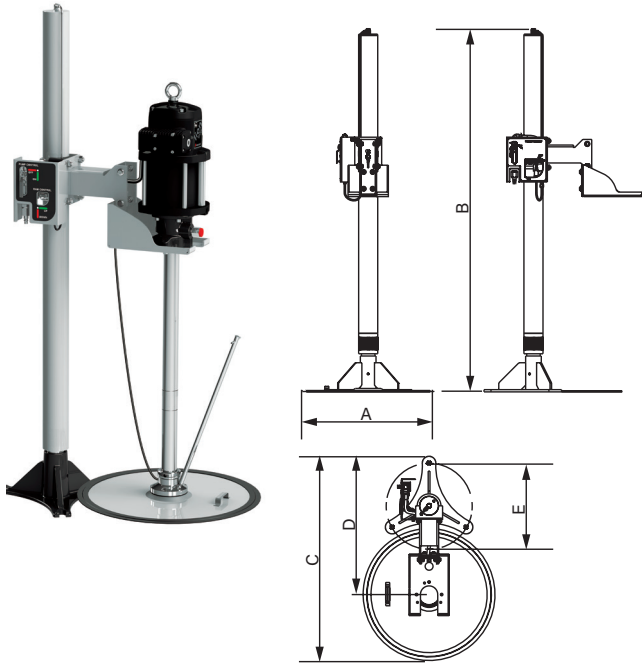

DIMENSIONS INCHES (MM)				
A	B LOWERED/ RAISED	C	D	E
23.25" (588 mm)	58" (1470 mm) 94.5" (2400 mm)	35.75" (910 mm)	24.03" (617 mm)	15" (381 mm)

## Fluids

- NLGI #2 Grease

## Applications

- High volume grease applications such as fifth wheel
- Medium / large volume vehicle maintenance shops
- Grease transfer
- In-plant grease supply

## Overview

Lion™ 450 and Lion™ 600 grease pumps are used with 400 lb drums in applications where higher volumes of grease are required. The air operated pump hoist lifts and lowers the pump, making drum changes easier, faster and safer. The pumps lower end is rigidly fixed to a follower plate with a single rubber lip. The weight of the pump, pump bracket and follower plate plus atmospheric pressure push the assembly against the grease eliminating channeling and air pockets, keeping grease free from contaminants, minimizing waste and aiding pump priming.

MODELS AVAILABLE	DESCRIPTION
<input type="checkbox"/> <b>1451-004</b>	Package, Lion™ 450, 40:1 Inductor Includes: 1450-002 Lion™ 450, 40:1 pump 4450-003 Inductor, Gravity, Pump Lift & follower plate
<input type="checkbox"/> <b>1451-005</b>	Package, Lion™ 450, 70:1 Inductor Includes: 1450-005 Lion™ 450, 70:1 pump 4450-003 Inductor, Gravity, Pump Lift & follower plate
<input type="checkbox"/> <b>1451-006</b>	Package, Lion™ 600, 80:1 Inductor Includes: 1450-008 Lion™ 600, 80:1 pump 4450-003 Inductor, Gravity, Pump Lift & follower plate

TECHNICAL DATA	
Diameter of the pneumatic cylinder	3" (75 mm)
Stroke of the pneumatic cylinder	36.6" (930 mm)
Minimum height of equipment	58" (1,470 mm)
Maximum height of equipment	94.5" (2,400 mm)
Air inlet	1/2" NPT(M)
Maximum air pressure	116 psi (8 bar)
Service Bulletin	SB 4228

**Warning!** Do not use any Lion™ 450/600 series products with flammable fluids.

Verify fluid compatibility with MSDS sheets.

Contact Balcrank for pumping grease higher than NLGI-2 and specific system design performance technical data.