



Used Fluid

## Overview

The Roughneck II drain captures used fluids and transfers them to any bulk storage tank. The unit uses regular shop air and can be pressurized to allow for self-evacuating.

- Patented automatic fluid evacuation valve eliminates gravity draining, pouring, or the need for an evacuation pump.
- 23 gallon storage tank; fewer drain intervals
- A low pressure safety valve prevents over pressurization of tank.
- Clear evacuation hose; provides fast fluid evacuation and shows fluid levels in tank.

### Includes:

- 19.25" diameter catch basin that features an inlet filter screen and s-hooks for tools.
- Splashguard bowl design prevents splattering, speeds drainage.
- Fully adjustable bowl height from 45" to 72"
- One hand operation. No ball valves required for evacuation of fluid.
- Roughneck outlet tube mounts securely into bulk used fluid reservoir.
- 7' evacuation tube provides sight gauge for fluid level.
- Tank handle makes maneuvering easy.
- Heavy gauge, all-Steel construction guarantees long life.
- Tip-resistant balanced design.
- Large diameter rear rubber wheels and non-marking wide front casters maneuver the toughest shop floors.

MODELS AVAILABLE	DESCRIPTION
<input type="checkbox"/> 4110-022	Roughneck II™ Used Oil Drain
<input type="checkbox"/> 4110-023	Roughneck II™ Used Anti-freeze Drain

TECHNICAL DATA	
Air Pressure Operating Range	5-25 psi (.34-1.72 bar)
Tank Capacity	23 gal (87 l)
Telescoping Range	45"-72" (1.14-1.83 m)
Maximum Pressure	25 psi (1.72 bar)
Pressure Relief Valve	30 psi (2.07 bar)
Air Inlet Size (quick connect)	1/4" NPT
Fluid Outlet Nozzle	1" OD
Estimated Evacuation Time	3 - 4 min.
Wetted Materials	Zinc Plated Steel, Steel, Viton®, HDPE, and PVC
Service Bulletin	SB 4027

## Roughneck II™ Drain Description

The Balcrank Roughneck II™ Drain will capture used fluids and transfer to any bulk storage tank. Unit will use regular shop air and be pressurized to allow for self-evacuating.

## Roughneck II™ Drain Details

- 2.1. The Balcrank Roughneck II™ drain will have an all Steel tank and base design made from heavy-gauge Steel, guaranteeing long life
- 2.2. The Balcrank Roughneck II™ drain will have patented one step-automatic fluid evacuation valve, which eliminates gravity draining, pouring, or the need for an evacuation pump.
- 2.3. The Balcrank Roughneck II™ drain will have a low-pressure safety valve to prevent over-pressurization.
- 2.4. The Balcrank Roughneck II™ drain will have 10" non-marking rubber wheels and 4" casters for easy maneuvering on any floor surface.
- 2.5. The Balcrank Roughneck II™ drainage bowl to be made from high strength poly to provide collapsible safety feature to assist in preventing tank failure when object is lowered onto drainage bowl. Drain will prevent splattering and include filter to keep debris from entering tank and speed drainage.
- 2.6. The Balcrank Roughneck II™ drain will have a 19.25" splashguard bowl design to prevent splattering and speeds drainage.
- 2.7. The Balcrank Roughneck II™ drain will have a tip resistant balanced design.
- 2.8. The Balcrank Roughneck II™ drain will be NFPA approved design.
- 2.9. The Balcrank Roughneck II™ drain will be powder coated for corrosion resistance with high quality powder coating. Drains are offered in black for used oil and green for used antifreeze.
- 2.10. The Balcrank Roughneck II™ drain will have a seven-foot evacuation tube that provides a built-in sight gauge for fluid level for fast and accurate viewing.

## Self-Evacuating Drain Models Available

- 4110-022** Used oil
- 4110-023** Anti-freeze

## Self-Evacuating Drain Specifications

- 4.1. Roughneck II™ drain will be 24" W x 45"H (72" H fully extended)
- 4.2. Roughneck II™ drain will have a bowl dimensions of 19.25" diameter
- 4.3. Roughneck II™ drain will have an operating air pressure of 5-25 psi (.34-1.72 bar)
- 4.4. Roughneck II™ drain will have a fluid outlet hose of 3/4" ID x 7' long
- 4.5. Roughneck II™ drain will have a fluid outlet nozzle of 1" OD
- 4.6. Roughneck II™ drain will have a pressure relief valve of 30 psi (2 bar)
- 4.7. Roughneck II™ drain will have a capacity of 23 gal (87 l)
- 4.8. Roughneck II™ drain will have a telescoping range of 47"-74" (1.14-1.83 m)
- 4.9. Roughneck II™ drain will have an estimated evacuation time of 3-4 minutes

## Materials

- 5.1. The Balcrank Roughneck II™ drain wetted materials will consist Zinc plated Steel, Steel, Viton, HDPE, and PVC

## Warranty

- 6.1. The Balcrank Roughneck II™ drain will have a 1-year parts, labor, and mileage warranty (defects in materials and workmanship only)

# Used Fluid Equipment - Premium Duty



## Overview

Premium drains capture used fluids and transfers them to any bulk storage tank using a cam-lock kit and evacuation system.

- All Steel tank and base design made from heavy gauge Steel, guaranteeing long life
- Non-marking rubber wheels and 4" casters for easy maneuvering on any floor surface.
- Drainage bowl made from high strength poly to provide collapsible safety feature.
- Tip resistant balanced design.
- Prevents splattering and include filter to keep debris from entering tank and speed drainage.
- High quality powder coating for corrosion resistance. Drains are offered in black for used fluid and green for used Anti-freeze (Glycol).
- Used oil drains will come with a 1" cam-lock nipple and dust cap.
- Used anti-freeze drains will come with a 3/4" cam-lock nipple and dust cap.

MODELS AVAILABLE	DESCRIPTION
<input type="checkbox"/> 4110-024	Premium Duty Used Oil Drain
<input type="checkbox"/> 4110-025	Premium Duty Used Anti-freeze (Glycol) Drain

TECHNICAL DATA	
Tank Capacity	23 gal (87 l)
Telescoping Range	45" - 72" (1.14 - 1.83 m)
Air Inlet Size (quick connect)	1/4" NPT
Fluid Outlet	Used oil 1" cam-lock nipple Used anti-freeze 3/4" cam-lock nipple
Wetted Materials	Zinc Plated Steel, Steel, Viton®, HDPE, and PVC
Service Bulletin	SB 4226

## Premium Duty Drain Description

The Balcrank Premium Drains will capture used fluids and transfer to any bulk storage tank using a quick coupler and evacuation system.

## Premium Duty Drain Details

- 2.1. Drain will have an all Steel tank and base design made from heavy-gauge Steel, guaranteeing long life
- 2.2. Drain will have non-marking rubber wheels and 4" casters for easy maneuvering on any floor surface.
- 2.3. Drainage bowl to be made from high strength poly to provide collapsible safety feature to assist in preventing tank failure when object is lowered onto drainage bowl. Drain will prevent splattering and include filter to keep debris from entering tank and speed drainage.
- 2.4. Drain will have a tip resistant balanced design.
- 2.5. Drain will be NFPA approved design.
- 2.6. Drainage bowl to be made from high strength poly to provide collapsible safety feature to assist in preventing tank failure when object is lowered onto drainage bowl.
- 2.7. Drain will prevent splattering and include filter to keep debris from entering tank and speed drainage.
- 2.8. Drain will be powder coated for corrosion resistance with high quality powder coating. Drains are offered in black for used oil and green for used antifreeze.

## Premium Duty Drain Models Available:

- 4110-024**            **Used oil**
- 4110-025**            **Anti-freeze**

## Premium Duty Drain Specifications:

- 4.1. Drain will be 24" W x 45"H (72" H fully extended)
- 4.2. Drain will have a capacity of 23 gal (87 l)
- 4.3. Drain will have a telescoping range of 45"-72" (1.14-1.83 m)
- 4.4. Drain will have fluid outlet of 3/4" NTP(M)

## Materials:

- 5.1 The wetted materials will consist Zinc plated Steel, Steel, Viton, HDPE, and PVC

## Warranty:

- 6.1 Drain will have a 1-year parts, labor, and mileage warranty (defects in materials and workmanship only)

# Used Fluid Equipment Spillguard



Used Fluid

## Overview

Spillguard drains capture used fluids and transfer to any bulk storage tank using a cam-lock kit and evacuation system

- Balcrank "wide track" 4" caster dolly set for easy maneuvering on any floor surface.
- All Steel cover, container, and base design
- Drainage bowl made from high strength poly to provide collapsible safety feature and to assist in preventing container failure when an object is lowered onto drainage bowl.
- Drain bowl prevents splattering and includes filter to keep debris from entering container and speed drainage.
- Tip resistant balanced design.
- High quality powder coating for corrosion resistance. Drains are offered in black for used fluid and green for used Anti-freeze (Glycol).
- Used oil drains will come with a 1" cam-lock nipple and dust cap.
- Used anti-freeze drains will come with a 3/4" cam-lock nipple and dust cap.

MODELS AVAILABLE	DESCRIPTION
<input type="checkbox"/> 4110-026	Spillguard used oil drain
<input type="checkbox"/> 4110-027	Spillguard used oil drain drumless
<input type="checkbox"/> 4110-028	Spillguard used anti-freeze (Glycol) drain
<input type="checkbox"/> 4110-029	Spillguard used anti-freeze (Glycol) drain drumless

TECHNICAL DATA	
Tank Capacity	16 gal (60.5 l)
Telescoping Range	0-27 in. (0-69 m)
Air Inlet (quick connect)	1/4" NPT
Fluid Outlet	Used oil 1" cam-lock nipple Used anti-freeze 3/4" cam-lock nipple
Wetted Materials	Zinc Plated Steel, Steel, Viton®, HDPE, and PVC
Service Bulletin	SB 4225

## Spillguard Drain Description

The Balcrank Spillguard Drains will capture used fluids and transfer to any bulk storage tank using a quick coupler and evacuation system.

## Spillguard Drain Details

- 2.1. Drain will have Balcrank "wide track" 4" caster dolly set for easy maneuvering on any floor surface.
- 2.2. Drain will have an all Steel cover, container, and base design, made in USA.
- 2.3. Drain will have a drainage bowl to be made from high strength poly to provide collapsible safety feature, to assist in preventing container failure when object is lowered onto drainage bowl.
- 2.4. Drain bowl will prevent splattering and include filter to keep debris from entering container and speed drainage.
- 2.5. Drain will have a tip resistant balanced design.
- 2.6. Drain will have a fluid level gauge included.
- 2.7. Drain will be powder coated for corrosion resistance with high quality powder coating. Drains are offered in black for used oil and green for used antifreeze.

## Spillguard Drain Models Available:

- 4110-026** Used Oil
- 4110-028** Anti-freeze
- 4110-027** Drumless Used Oil Drain
- 4110-029** Drumless Anti-freeze Drain

## Spillguard Drain Specifications:

- 4.1. Drain will be 24" W x 55"H (61" H fully extended)
- 4.2. Drain will have bowl dimensions of 19.25" diameter
- 4.3. Drain will have a capacity of 16 gal (60.5 l)
- 4.4. Drain will have a telescoping range of 0-27 in. (0-69 m)
- 4.5. Drain will have fluid outlet of 3/4" NPT(M) for Anti-freeze and 1" NPT(M) for Used Oil

## Materials:

- 5.1. The wetted materials will consist of Zinc-plated Steel, Steel, Viton, HDPE, and PVC

## Warranty:

- 6.1. Drain will have a 1-year parts, labor, and mileage warranty (defects in materials and workmanship only)

# Used Fluid Equipment Evacuators



## Overview

- Extract used oil and other fluids from any vehicle - safer, cleaner
  - No more stripped drain plugs
  - Great for cars, boats, motorcycles, and small engines
  - Easily remove overfills
  - Vacuum-charged unit is completely portable and easy to use
  - Includes six suction probes (metal and flexible)
  - Suction probes equipped with quick disconnect couplers
  - Adapters for BMW and Volkswagen included
  - Self-evacuating feature makes emptying clean and easy
  - Available version with clear bowl
- Capacity: 2 gal (7.5 l)

MODELS AVAILABLE	DESCRIPTION
<input type="checkbox"/> 4140-056	Oil Evacuators
<input type="checkbox"/> 4140-057	Oil Evacuators with Clear Domes and Mercedes Adapter

TECHNICAL DATA		
	4140-056	4140-057
Tank capacity	18.5 gal (64.35 l)	18.5 gal (64.35 l)
Max. draining capacity	70%	80%
Air pressure for vacuum	100 psi (7 bar)	100 psi (7 bar)
Depressurization time	2' 15"	2' 15"
Suction hose	6 1/2" (2m)	6 1/2" (2m)
Draining hose	5' (1.5 m)	5' (1.5 m)
Service Bulletin	SB 4081	SB 4082

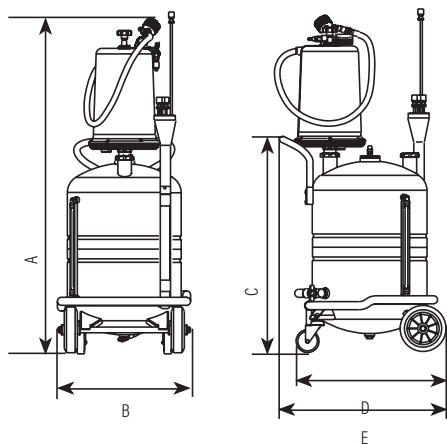

DIMENSIONS INCHES (MM)				
A	B	C	D	E
46.06" (1,170)	18.5" (470)	29.5" (750)	18.70" (475)	22.84" (580)

### Evacuator Details

- 2.1. Evacuator will have six suction probes (metal and flexible)
- 2.2. Evacuator will have suction probes equipped with quick disconnect couplers
- 2.3. Evacuator will have adapters for BMW and Volkswagen included
- 2.4. Clear bowl version will have a capacity of 2 gal (7.5 l)

### Evacuator Models Available:

- 4140-056** Oil Evacuator
- 4140-057** Oil Evacuator with Clear Dome and Mercedes Adaptor

### Evacuator Specifications:

- 4.1. Evacuator will have a tank capacity of 18.5 gal (64.35 l)
- 4.2. Evacuator will have 100 psi (7 bar) air pressure for vacuum
- 4.3. Evacuator will have depressurization time of 2 hr and 15 min
- 4.4. Evacuator drain hose will be 5' (1.5 m) in length
- 4.5. Evacuator will have a 6.5" (2 m) suction hose

### Warranty:

- 6.1. Evacuator will have a 1-year parts, labor, and mileage warranty (defects in materials and workmanship only)



# Used Fluid Equipment Truck Drain





## Features

The Truck Drain comes pre-assembled allowing for immediate use. Designed to capture used fluids. Includes "used oil only" and "used anti-freeze only" decals for fluid identification. Connects to a used oil evacuation system using a dry-break or cam-lock kit (sold separately) and evacuation system.

- Two fixed 8" wheels and one swivel caster on rear
- Double baffles with upper screen and a catch lip help prevent fluid from splashing out
- Tubular U-handle design for excellent maneuvering
- Powder coated for corrosion resistance with high quality powder coating. Drains are available in safety yellow.
- All Steel design

### Cam-Lock Coupler & Nipple rated for vacuum or up to 3,000 psi (207 bar)

Cam-Lock Kits		4140-061 Cam-Lock Kit 1" for used oil for use with Pit Boss Bare 4140-020  Includes: Fluid Ball Valve, Cam-Lock nipple, Cap, and Hex nipple
		4140-067 Cam-Lock Kit 3/4" for anti-freeze for use with Pit Boss Bare 4140-020  Includes: Fluid Ball Valve, Cam-Lock nipple, Cap, and Hex nipple
Hose Kit for waste oil evacuation		4140-013 Hose Kit for waste oil evacuation Includes: 4140-017 - Cam-lock coupler 1" x 1", 8181-002X - Hose low pressure 2.5' x 1"

MODELS AVAILABLE	DESCRIPTION
<input type="checkbox"/> 4120-006	Truck Drain Bare

TECHNICAL DATA	
MODELS	4120-006
Tank Capacity	26 gal (98.4 l)
Fluid Outlet	1"
Measurements	9" H x 24" W x 36" L
Wetted Materials	Zinc Plated Steel, Steel, Viton®, HDPE, and PVC
Service Bulletin	SB 4051

## Truck Drain Description

The Balcrank Truck drain will come pre-assembled allowing for immediate use. Truck drain will be designed to capture used fluids. Truck drain will include "used oil only" and "used anti-freeze only" decals, for ease of fluid identification. Truck drain can connect to a used fluid evacuation system.

## Truck Drain Details

- 2.1. Drain will have two fixed 8" wheels and 1 swivel caster for easy maneuvering.
- 2.2. Drain will have an all Steel design, not to be more than 9" in height, made in USA.
- 2.3. Drain will have double baffles with upper screen and a catch lip help prevent oil from splashing out.
- 2.4. Drain will have a tubular U-handle design for excellent maneuvering.
- 2.5. Drain will be powder coated for corrosion resistance with high quality powder coating. Drains are available in safety yellow.

## Truck Drain Models Available:

- 4120-006** Truck Drain

## Truck Drain Specifications:

- 4.1. Drain will be 36"L x 24"W x 9"H
- 4.2. Drain will have a fluid outlet of 1" NPT (F)
- 4.3. Drain will have a capacity of 26 gal (98.4 l)

## Materials:

- 5.1. The wetted materials will consist of Zinc-plated Steel, Steel, Viton, HDPE, and PVC

## Warranty:

- 6.1 Drain will have a 1-year replacement only warranty (defects in materials and workmanship only)

# Used Fluid Equipment Drain-Pit Boss



## Overview

The Pit Boss rolling pit drain captures used fluids. Specifically designed to easily roll on guide tracks in the user's pit and connect to a used fluid evacuation system.

- Two anti-splash baffles, side splash guards and a metal catch screen.
- Front and rear drain ports.
- 3" diameter wheels which are mounted to accommodate a pit track width of 34" to 53".
- Tool shelf below the tank for pit service tools.
- All Steel design

MODELS AVAILABLE	DESCRIPTION
<input type="checkbox"/> 4140-060	Drain - Pit Boss with Quick Connect Kit 4140-061
<input type="checkbox"/> 4140-020	Drain - Pit Boss Bare

Cam-Lock Coupler & Nipple rated for vacuum or up to 3,000 psi (207 bar)		
Cam-Lock Kits		4140-061 Cam-Lock Kit 1" for used oil for use with Pit Boss Bare 4140-020  Includes: Fluid Ball Valve, Cam-Lock nipple, Cap, and Hex nipple
		4140-067 Cam-Lock Kit 3/4" for anti-freeze for use with Pit Boss Bare 4140-020  Includes: Fluid Ball Valve, Cam-Lock nipple, Cap, and Hex nipple
Hose Kit for waste oil evacuation		4140-013 Hose Kit for waste oil evacuation Includes: 4140-017 - Cam-lock coupler 1" x 1", 8181-002X - Hose low pressure 2.5' x 1"

TECHNICAL DATA	
MODELS	4140-060 4140-020
Tank Capacity	34 gal (128.7 l)
Fluid Outlet	4140-060 1" cam-lock nipple 4140-020 1" NPT(F) bare
Measurements	16.72" H x 28.4" W x 34" L, 2" adjustable unit height
Wetted Materials	Zinc Plated Steel, Steel, Viton®, HDPE, and PVC
Service Bulletin	SB 4018

## Rolling Pit Drain Description

The Balcrank Pit Boss Rolling pit drain will capture used fluids. Pit Boss will be specifically designed to easily roll on guide tracks in the user's pit and connect to a used fluid evacuation system.

## Rolling Pit Drain Details

- 2.1. Pit Boss Rolling pit drain will include a metal catch screen.
- 2.2. Pit Boss Rolling pit drain will have two anti-splash baffles.
- 2.3. Pit Boss Rolling pit drain will have side splash guards.
- 2.4. Pit Boss Rolling pit drain will have a ball drain valve.
- 2.5. Pit Boss Rolling pit drain will have a cam-lock half coupler included.
- 2.6. Pit Boss Rolling pit drain will have front and rear drain ports.
- 2.7. Pit Boss Rolling pit drain will have 3" diameter wheels which are mounted to accommodate a pit track width of 34" to 53."
- 2.8. Pit Boss Rolling pit drain will have a tool shelf below the tank for pit service tools.
- 2.9. Pit Boss Rolling pit drain will have an all Steel design, made in USA.
- 2.10. Pit Boss Rolling pit drain will be powder coated for corrosion resistance with high quality powder coating. Drain is available in safety yellow.

## Rolling Pit Drain Models Available:

- 4140-020** Bare
- 4140-060** Pit drain with connection kit

## Rolling Pit Drain Specifications:

- 4.1. Drain will be 34" L x 28.4" D x 16.72"H (extends to 53.50")
- 4.2. Drain will have adjustable roller height is 2" (51 mm)
- 4.3. Drain will have capacity is 34 gal (1287 l)
- 4.4. Drain will have fluid outlet of 1" NPT (F)

## Materials:

- 5.1. The wetted materials will consist of Zinc-plated Steel, and Steel, Viton, HDPE and PVC

## Warranty:

- 6.1. Drain will have a 1-year parts replacement only warranty (defects in materials and workmanship only)