

Oil Piston Pumps

LYNX® 1:1 - 1:1 Stainless Steel Pump

The LYNX® 1:1 ratio double acting pump is engineered for outstanding performance and reliability to dispense lubricating oils and similar products up to SAE 90.

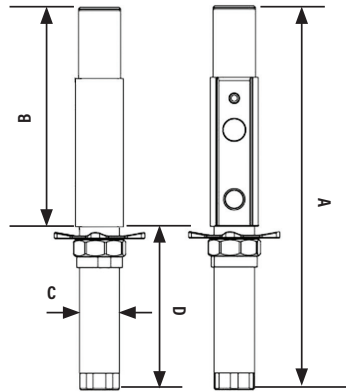

DIMENSIONS INCHES (MM)			
1110-010			
A	B	C	D
19 9/16" (497 mm)	11 1/4" (286 mm)	2 3/64" (52 mm)	8 5/16" (211 mm)
1110-009			
46 1/2" (1181 mm)	11 1/4" (286 mm)	2 3/64" (52 mm)	35 1/4" (895 mm)
1160-008			
47 1/4" (1200 mm)	11 1/4" (286 mm)	2" (50 mm)	36" (914 mm)

TECHNICAL DATA	
Operating air pressure	45 -150 psi (3 -10 bar)
Cycles per gallon	31 cyc/gal (8.2 cyc/liter)
Air consumption 100 psi (7 bar) & 3 gal/min (11 l/min)	3.50 scfm
Max Fluid stall pressure @ 150 psi (10 bar) ⁽¹⁾	145 psi (10 bar)
Effective Air Piston Diameter	1.375" (35 mm)
1110-010, 1110-009 Free flow pump delivery with SAE 10W30 oil, 68 °F (20 °C), 150 psi (10 bar) air pressure	10.6 gal/min (40 l/min)
1160-008 Free flow pump delivery with SAE 10W30 oil, 68 °F (20 °C), 150 psi (10 bar) air pressure	8.2 gal/min (30 l/min)
Air inlet	1/4" NPT(F)
Fluid inlet (stub only)	1" NPT(F)
Fluid outlet 1110-010, 1110-009	3/4" NPT(F)
Fluid outlet 1160-008	3/4" NPT(F)
Wetted materials 1110-010 & 1110-009	Steel, Brass, Aluminum, Buna-N™, and Polyurethane
1160-008	Stainless Steel, Viton, and PTFE
Service Bulletin 1110-010, 1110-009	SB 1102
Service Bulletin 1160-008	SB 1143

NOTE: Thermal expansion of the fluid in a distribution system can cause an increase in system pressure that can damage lubrication system components. Use pressure relief valve kit 3120-086 for this pump.

(1) Ensure that all hose fittings and piping are rated for fluid outlet pressures. Balcrank recommends a minimum of 3x safety factor.

Warning! Do not use any LYNX® series products with flammable fluids.

Verify fluid compatibility with MSDS sheets.

Contact Balcrank for specific system design performance and technical data.

Fluids & Applications

1

The LYNX® series pump is perfect for small volume users, for synthetics, gear oils, and standard mineral oils.

The 1:1 version is best for higher volume with short distance requirements such as oil bars, taper pumps and medium to light viscosity oils pumping short distances.

Fluids

- Synthetic and mineral based lubricants
- Hydraulic fluid
- Transmission fluid
- Anti-freeze/windshield wash fluids (stainless version)

Applications

- Taper pumps
- Oil bar supply (pumping short distance)
- Roll-around synthetic or mineral oil packages
- Medium volume dispensing in agricultural, in-plant, and maintenance shop applications

Pressure relief valve kit 3120-086 for this pump not included.

MODELS AVAILABLE	DESCRIPTION
1110-010	1:1 Bare carbon steel stub pump with bung adapter
1110-009	1:1 Bare carbon steel drum pump with bung adapter
1160-008	1:1 Bare stainless steel drum pump with bung adapter
3120-086	Kit, Pressure Relief, 3/4", 850 psi (59 bar)

