

Oil Piston Pumps PANTHER® HP 3:1 Pumps

The Panther® HP 3:1 ratio double acting pump is engineered for outstanding performance and reliability for dispensing lubricating oils and similar products up to SAE 90.

1

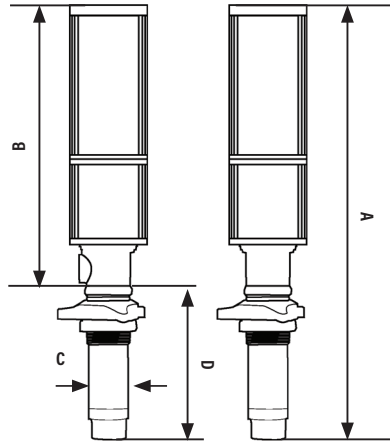

DIMENSIONS INCHES (MM)			
1130-015 & 1130-020			
A	B	C	D
23.5" (523.9 mm)	14 3/8" (285 mm)	2 1/8" (54 mm)	6 1/2" (158.7 mm)
1130-017			
21 8/9" (555.6 mm)	14 3/8" (285 mm)	2 1/8" (54 mm)	7 1/2" (190.5 mm)

TECHNICAL DATA	
Operating air pressure	10-150 psi (7-10 bar)
Cycles per gallon	34 cyc/gal (8.98 cyc/liter)
Air consumption 100 psi (7 bar) & 4 gal/min (15 l/min)	19.70 SCFM
Max. fluid stall pressure @150 psi (10 bar) ⁽¹⁾	490 psi (33.7 bar)
Effective air piston diameter	2.5" (63.5 mm)
Free Flow pump delivery with SAE 10W30 oil, 68° F (20° C), 100 psi (7 bar) air pressure	8 gal/min (30 l/min)
Air inlet	1/4" NPT(F)
Fluid inlet	1" NPT(F); 1 1/2" NPT(M)
Fluid outlet	3/4" NPT(F)
Wetted materials	Steel, Nickel Plated Steel, Stainless Steel, Aluminum, Ultrathane, Buna-N™, and Nylon
Service Bulletin	SB 1064

NOTE: Thermal expansion of the fluid in a distribution system can cause an increase in system pressure that can damage lubrication system components. Use pressure relief valve kit included with this pump.

(1) Ensure that all hose fittings and piping are rated for fluid outlet pressures. Balcrank recommends a minimum of 3 x safety factor.

Warning! Do not use any Pride series products with flammable fluids.

Verify fluid compatibility with MSDS sheets.

Contact Balcrank for specific system design performance and technical data.



Fluids & Applications

Pride Series pumps are manufactured with a mechanical air valve and piston design which is more forgiving to environments with contaminated air. The 3:1 version is a medium pressure pump for supplying higher volume than the 5:1 version but at lower operating pressures ideal for medium pumping distances and overall flow rates of 4-5 gpm.

Fluids

- Synthetic and mineral based lubricants
- Hydraulic fluid
- Transmission fluid

Applications

- Medium sized tank packages
- Medium volume maintenance shops
- Small car dealerships
- Quick lubes

Pressure relief valve kit included with this pump.

MODELS AVAILABLE	DESCRIPTION
1130-015	3:1 Bare carbon steel stub pump
1130-017	3:1 Bare carbon steel stub pump, flange mount
1130-020	3:1 Bare carbon steel pump with bung adapter

