

Description

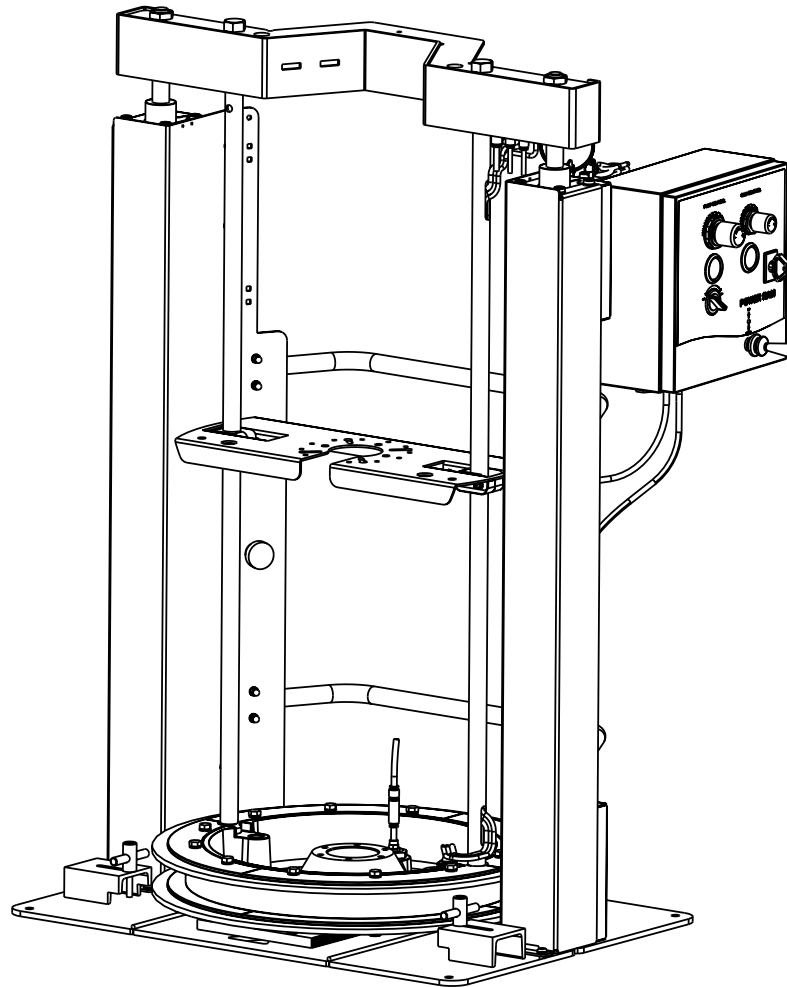

Fig. 1

Fixed inductor for the supply of grease. Operated by compressed air. This unit uses two pneumatic cylinders connected with a metal structure and protected with metal fairing fixed to a reinforced base plate, resulting in a very robust piece of equipment that is very small for the type of drums with which it can work.

This unit, supplied with all the components necessary for its use, was designed to supply grease with the greater guarantee of priming of the pump, and maximum use of the grease drums, compatible with this model of inductor.

It incorporates a robust aluminium inductor plate, which has a sealing system made up of lip seals or double O-rings. This system guarantees the walls of the drum are clean and that it is perfectly

sealed, which keeps impurities from getting in and protects from the weather. There are also different pump kits designed to optimise the work depending on the use required of this unit.

When the unit is correctly secured, the plate can be raised together with the pump to a given height to facilitate changing the used drum.

This unit has a control cabinet for the inductor and for the pump installed in the unit. This control cabinet has all the systems necessary to facilitate the inductor plate going into and out of the drum.

2018_06_06-820

Warning and cautions

WARNING

THIS SYMBOL BE AWARE OF SERIOUS BODILY INJURY OR DEATH IF YOU IGNORE THE WARNING DESCRIBED.

CAUTION

THIS SYMBOL BE AWARE OF PERSONAL INJURY OR PROPERTY DAMAGE IF YOU IGNORE THE CAUTION DESCRIBED.

CALIFORNIA PROPOSITION 65

THIS PRODUCT CONTAINS A CHEMICAL KNOWN TO THE STATE OF CALIFORNIA TO CAUSE CANCER, BIRTH DEFECTS OR OTHER REPRODUCTIVE HARM. WASH HANDS AFTER HANDLING.

Read before use

WARNING

Read all instruction manuals, tags, and labels before operating the equipment.

This equipment is for professional use only.

Do not alter or modify this equipment. Use genuine components provided from Balcrank Corporation.

Non compatible fluids may cause damage in the pump and serious personal injury.

The pump generates high or very high pressures. Do not exceed the maximum air inlet pressure of 145 psi (10 bar).

Do not exceed the drum's pressure limits. Be sure of the drum's pressure limitations and regulate the pressure within the safety limits when supplying air to the inductor plate. Do not try to use the unit until you have taken all possible precautions to guarantee that the unit has been

installed correctly, is level, and that the base has been firmly secured to the concrete floor.

Avoid electrical discharges. Ensure there are no electrical cables, devices or accessories above the lift. Examine the work area and take the measures necessary to ensure that enough space is maintained for the installation of the lift and for the pump to be lifted as much as necessary and that they work correctly.

Maintain a minimum safety distance when raising and lowering the inductor. Do not get too close; operate it from a safe place, so you cannot get trapped between the unit and its mobile elements. Take care when inserting the inductor plate into the drum.

When not in use, be sure to shut off the air supply to avoid accidents.

Check that all the operators that work with this unit have been trained in safe working practices, that they understand their limitations and use safety equipment when required.

Installation

WARNING

IF THE UNIT IS NOT INSTALLED CORRECTLY THIS CAN RESULT IN SERIOUS INJURY OR MATERIAL DAMAGE. READ THE WARNINGS. (SEE WARNINGS AND PRECAUTIONS).

This unit comes completely assembled, apart from the following details for proper installation and commissioning.

The unit is supplied with the control cabinet in the transport position. To place the control panel in the working position, simply disconnect pipes A and B from the control panel (fig. 5) and remove the pin from the hole locking the control panel (see upper arrows) and lower the control panel into its new working position (see arrow for rotational direction). Once the control panel is in place, insert the pin making sure the holes of the new position coincide. This will lock it in the working position. Then connect the pipes in the lower part of the control panel according to the diagram (see fig. 5).

To facilitate its handling, the unit is supplied with a pallet system integrated in the design. This system is composed of two galvanised sheet metal profiles bolted to the base plate. Once you have selected where you will secure the unit, it is necessary to remove these profiles; to do this, loosen and remove the screws that secure them and then

remove the profiles in the direction of the arrows (Fig. 3). Take care when doing so to avoid possible accidents.

Once the definitive location of the unit has been decided, pay special attention to the work area that will be above the inductor; this work area shall be free of objects and any electrical devices and ensure that the floor is level. Once you have finished the above step, secure the unit definitively. To do this, firmly secure the base to the concrete floor using anchor bolts (not included in the supply). The base plate itself can be used as a pattern to establish the correct fixing locations.

To finish the installation process, connect pipes A and B (Fig. 5) to the pneumatic control panel according to the details in the drawing. The unit is tested and verified in the factory but it is a good idea to check it at its destination. Connect it to a compressed air inlet with a maximum pressure of 145 psi (10 bar) and check that all the accessories of the pneumatic system are in good condition after transport. The control cabinet enables you to regulate the pneumatic actuator for raising and lowering the cylinders independently and to regulate the pump pressure.

To extend the life of the unit and the pump, use a filter at the control panel input.

The control panels are regulated in the factory to an approximate pressure of 72.5 psi (5 bar) for the pneumatic actuator and 72.5 psi (5 bar) for the pneumatic pump.

¡TRANSPORT POSITION! ¡WORKING POSITION!

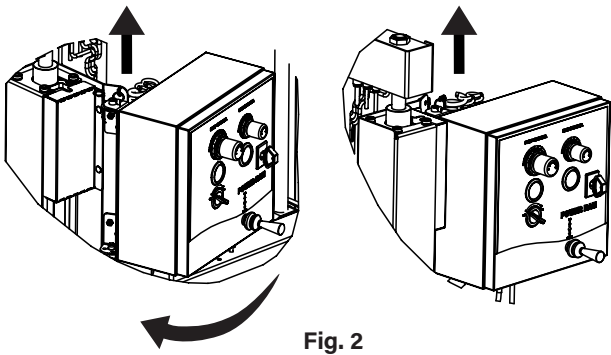

Fig. 2

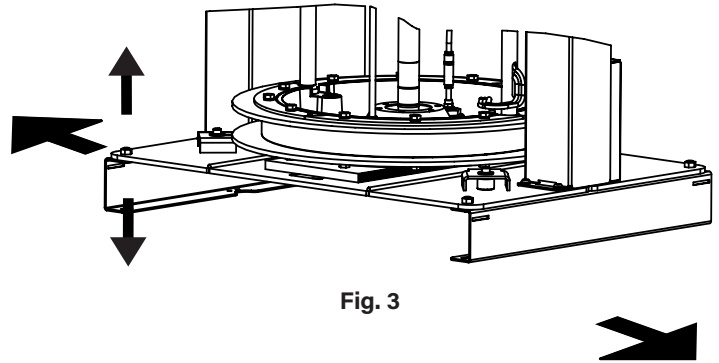

Fig. 3

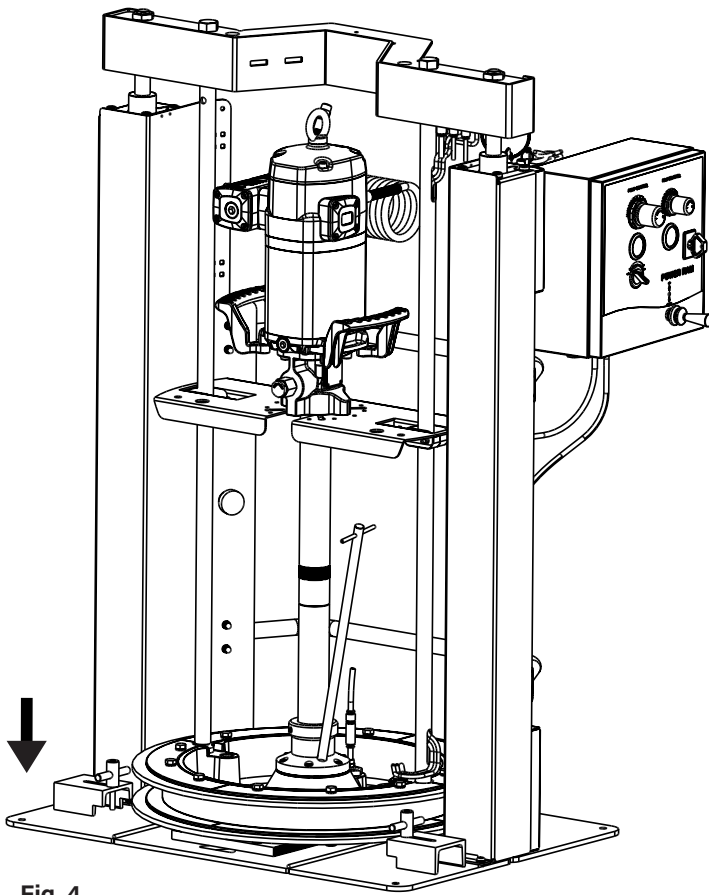

Fig. 4

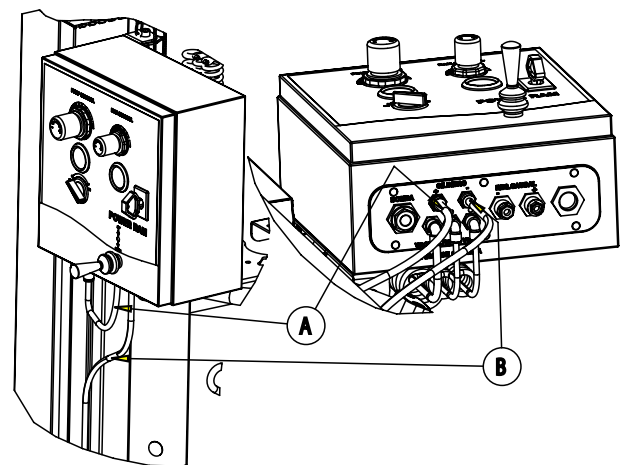

Fig. 5

2018_06_06-820

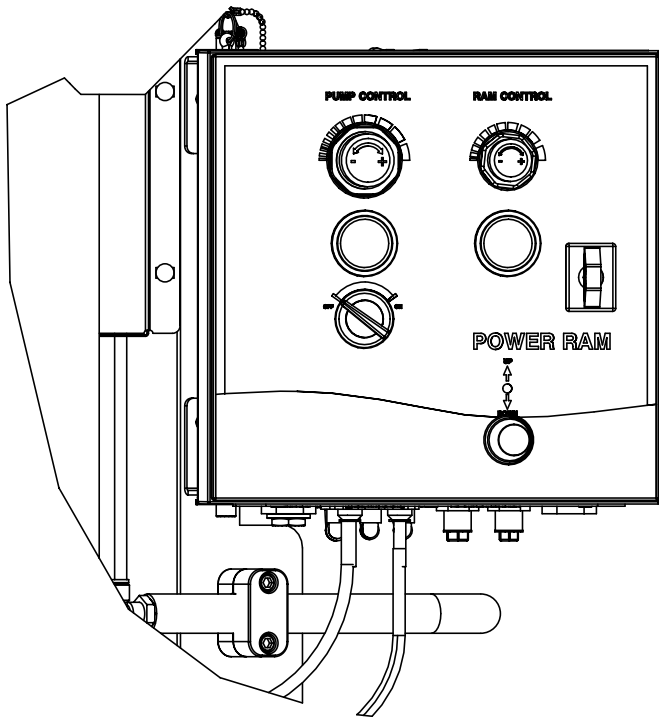

Fig. 6

 **CAUTION**

To raise the inductor for the first time:

1. Ensure there is nothing above the lift. In addition, read the WARNINGS AND PRECAUTIONS on page 2.
2. Move the control cabinet lever to the "UP" position. Do not touch any part of the unit while it is moving!
3. Lift the inductor plate higher than the top of the drum. Stop the lift ascending further by moving the control cabinet lever to the "NEUTRAL" position (center).

To raise the inductor, (normal operation):

1. Before raising the inductor, the pump control valve must be in the "OFF" position.
2. With new gaskets the pressure indicated on the "Ram Control" dial must be 87-100 psi (6-7 bar) (with softer used gaskets the pressure may be lower, to reduce slight fluid leakage). To adjust the inductor air pressure, pull out the "Ram Control" regulator control so it can be turned, clockwise to increase the pressure and counter-clockwise to reduce it. To set the pressure, push the regulator towards the control box and lock it again.
3. Move the control cabinet lever to the "UP" position.
4. Lift the inductor plate higher than the top of the drum. Stop the lift from ascending further by moving the control cabinet lever to the "NEUTRAL" position (center).

Grease drum installation

1. Check that the control cabinet lever is in the "NEUTRAL" position (center).
2. Slide the 400 lb drum along the base of the inductor. It will stop up against the inductor limiters. Always use drums that are compatible with this unit. Do not use damaged drums as they can cause the inductor plate to get stuck in the drum.
3. Unscrew the bleed rod from the inductor plate, keeping it nearby or using the housing designed to hold it in the inductor pump brackets.
4. Move the control cabinet lever to the "DOWN" position.
5. Let the inductor plate descend through the drum. When the air stops and the grease starts to flow through the bleed hole, stop the inductor by moving the control cabinet lever to the "NEUTRAL" position (center).
6. Insert the bleed rod and tighten it correctly.
7. The unit is now ready to work with. The pump should already be operative.

Grease supply

1. Select the "DOWN" position in the lift control cabinet, the inductor plate will compress the grease, priming the pump.
2. Start the pump by placing the "Pump Control" valve in the "ON" position.
3. The pump/inductor can now supply grease through the output hose until the drum is empty, the speed of emptying can be monitored by opening and closing the end of the output hose. When the inductor plate touches the bottom of the drum the inductor plate sensor is activated and stops the pump.
4. Before raising the inductor to replace the drum, the pump control valve must be in the "OFF" position.
5. Move the control cabinet lever to the "UP" position. In this position the cylinders go up in the unit and a current of air enters the drum to push the inductor plate.
6. Lift the inductor plate higher than the top of the drum. Stop the lift ascending further by moving the control cabinet lever to the "NEUTRAL" position (center).

 **WARNING**

WHILE THE EQUIPMENT IS CONNECTED TO THE AIR LINE, BE AWARE OF THE DANGER OF BEING TRAPPED BY THE MOBILE ELEMENTS OF THIS EQUIPMENT.

FOR YOUR OWN SECURITY AND TO PROLONG YOUR PUMPS LIFETIME UNPLUG THE AIR INLET COUPLER AFTER USING THIS EQUIPMENT.

2018_06_06-820

Inductor Packages

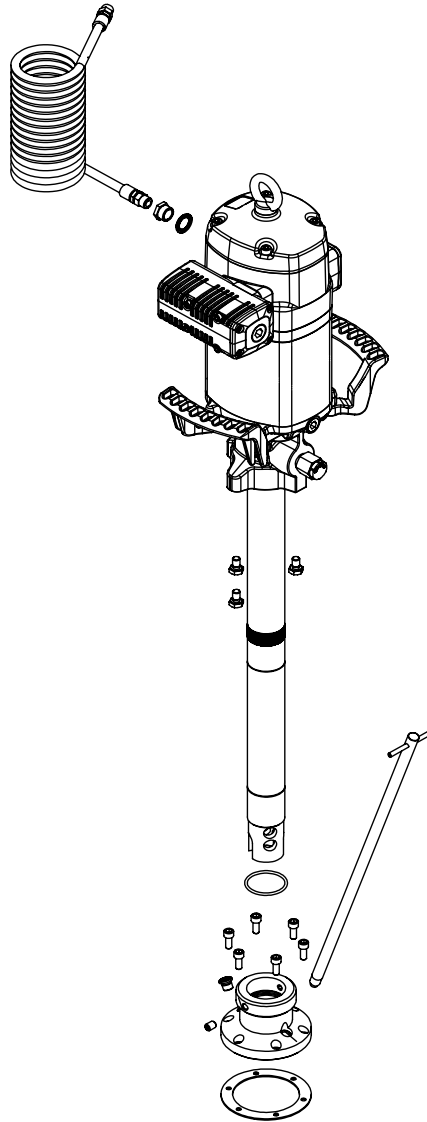

DOUBLE POST: 4450-004*

*Includes a follower plate

Designed for pumps:

1450-003 Lion 450, 40:1 120 LB

1450-006 Lion 450, 70:1 120 LB

1450-009 Lion 600, 80:1 120 LB

INDUCTOR PACKAGE		INDUCTOR		PUMP		COLLAR KIT	FOLLOWER KIT
Item #	Description	Inductor	Description	Item #	Description	Item #	Item #
1451-001	Lion 450, 40:1	4450-004	Double Post	1450-003	Lion 450, 40:1 120 LB	833650*	Included in 4450-004
1451-002	Lion 450, 70:1			1450-006	Lion 450, 70:1 120 LB		
1451-003	Lion 600, 80:1			1450-009	Lion 600, 80:1 120 LB		

Technical data

Pumps	Lion 450, 40:1 1450-003	Lion 450, 70:1 1450-006	Lion 600, 80:1 1450-009
Maximum air pressure	200 psi (14 bar)	100 psi (7 bar)	100 psi (7 bar)
Minimum air pressure	21 psi (1.5 bar)	21 psi (1.5 bar)	21 psi (1.5 bar)
Maximum grease delivery (A)	24.25 lbs/min (11 kg/min)	16.53 lbs/min (7.5 kg/min)	17.64 lbs/min (8 kg/min)
Air inlet thread	1/2" NPT	1/2" NPT	1/2" NPT
Grease outlet thread	1/2" NPT	1/2" NPT	1/2" NPT
Air piston diameter	4 1/2" (115 mm)	4 1/2" (115 mm)	6" (150 mm)
Air piston stroke	4" (100 mm)	4" (100 mm)	4" (100 mm)

INDUCTOR TECHNICAL DATA	
Diameter of the pneumatic cylinder	3.15 in (80 mm)
Stroke of the pneumatic cylinder	39.37 in (1000 mm)
Minimum height of equipment	52 in (1320 mm)
Maximum height of equipment	87.81 in (2230 mm)
Dimensions of the base	32.68 in x 23.62 in (830 mm x 600 mm)
Air inlet thread	1/2" NPT
Maximum air pressure	140 psi (10 bar)
Wetted Parts	Aluminum, zinc plated steel, Buna-n, Viton

***KIT: 833650 includes collar, air hose, hardware, bleed rod.**

Dimensions

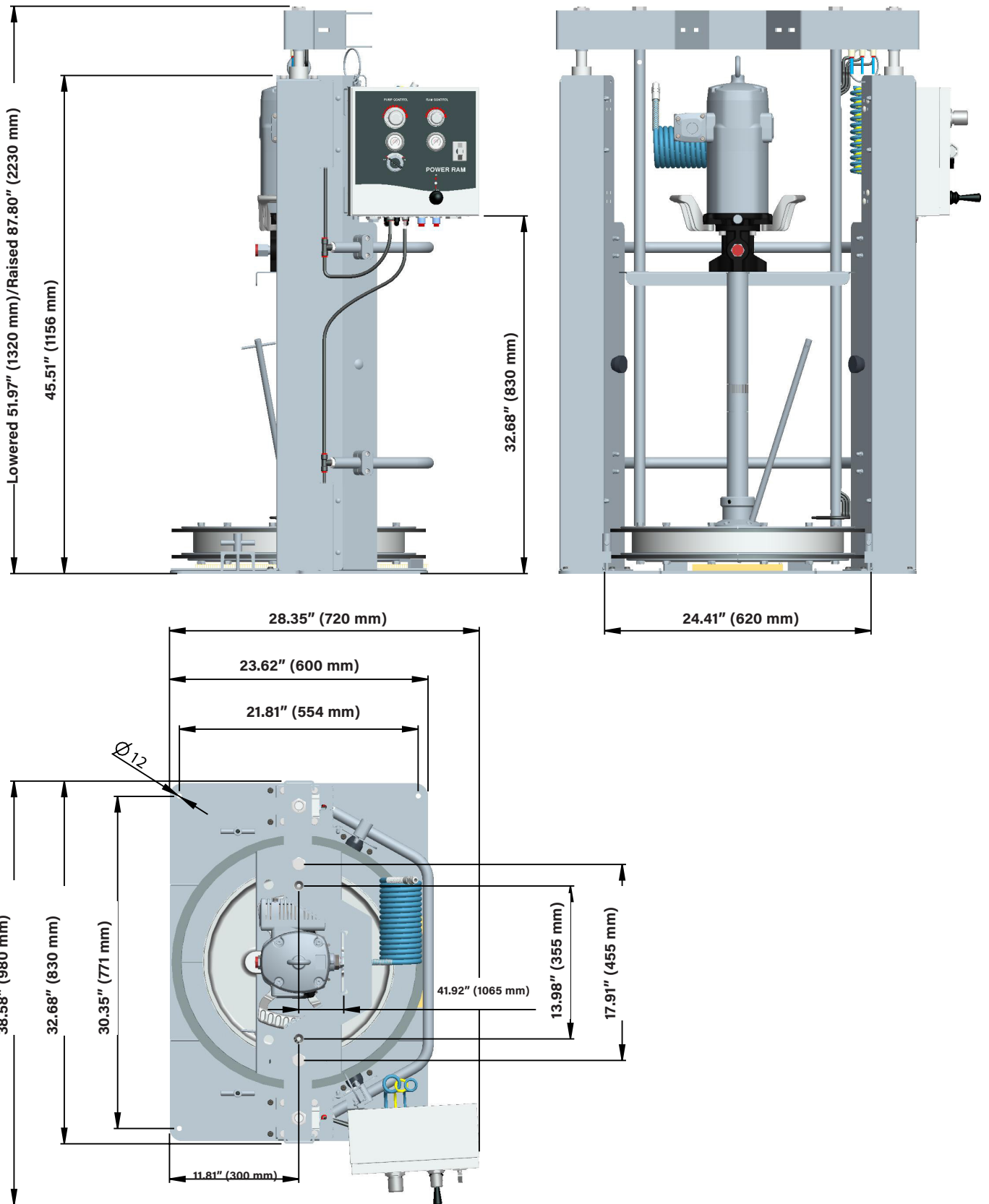

2018_06_06-820

Spare parts

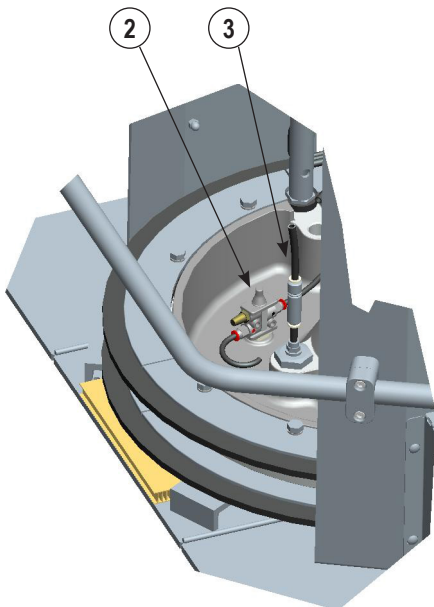
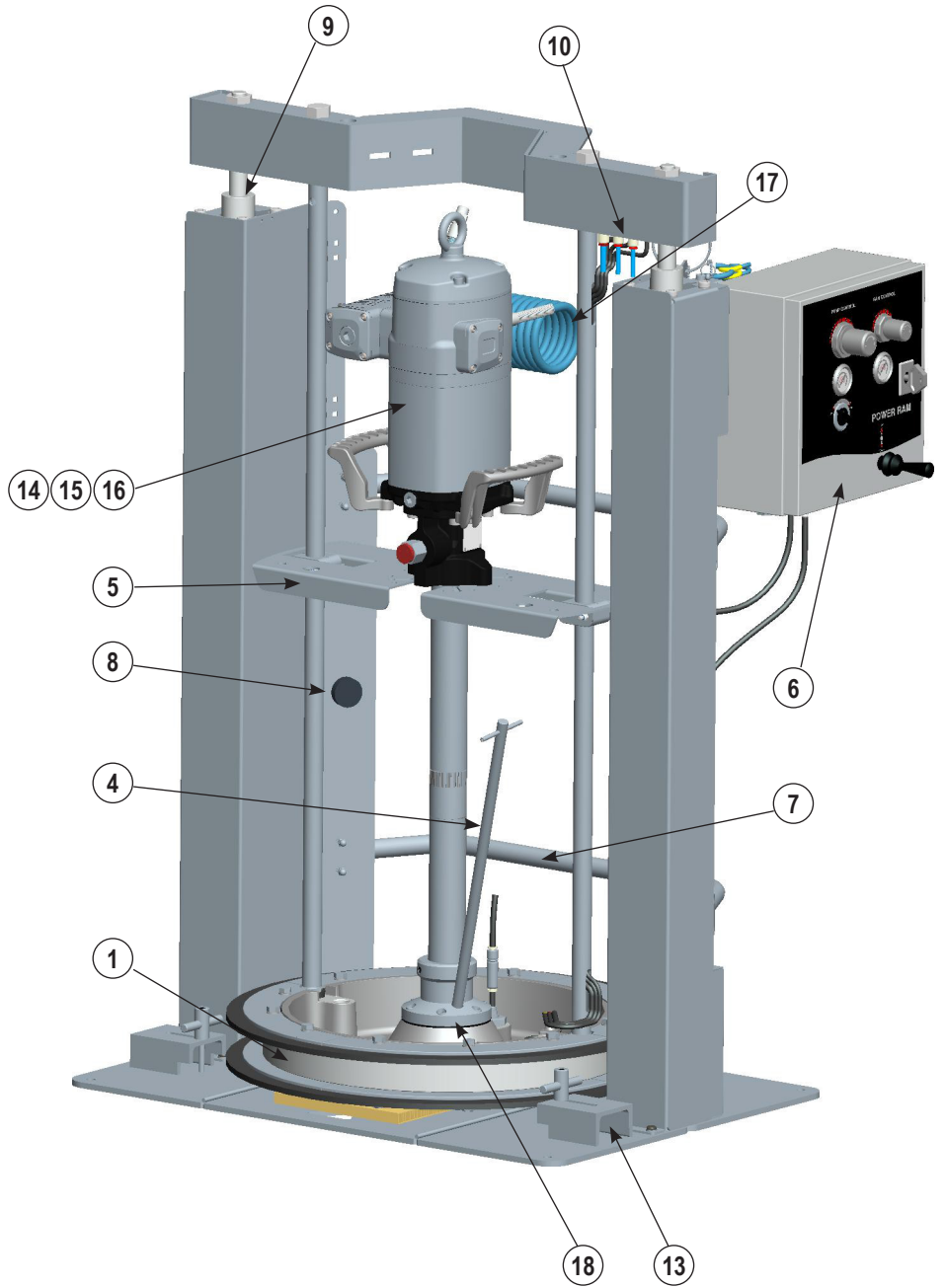
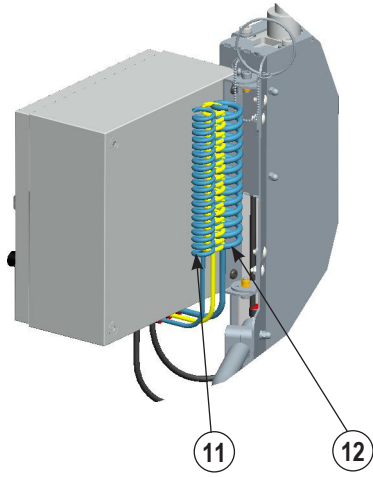

2018_06_06-820

Spare parts

Pos.	Part No.	Description	Qty.
1	739 100	Inductor plate body	1
	739 201	Strip for closing inferior lower	4
	739 202	Strip for closing upper	4
	739 225	Strip for closing intermediate	4
	839 500	Gasket cleaning plate (lower)	1
	839 501	Gasket cleaning plate (upper)	1
	940 042	Hexagonal bolt M10x30 DIN-933	12
	940 044	Hexagonal bolt M10x25 DIN-933	12
	942 210	Spring washer B10 DIN-127	24
2	839200-3	Limiter valve 3/2 NC R1/8"	1
	839200-4	Straight connector R1/8" to pipe of 6 mm	2
	839200-5	Limiter silencer R1/8"	1
3	839200-8	In-line anti-return for pipe of 8 mm	1
	839200-11	Straight connector R1/4" M for pipe of 8 mm	1
4	842 406	Bleed rod set	1
5	739 214	Pump support	1
	940 221	Flat-headed bolt M6x60 DIN-603	4
	941 107	Self-locking nut M6 DIN-985	4
	960 306	Stauff clamp G3/4"	2
6	839200-1	Pneumatic control panel	1
7	739 217	Air receiver	1
	839200-6	Compact elbow 1/2" for pipe of 8 mm	1
	839200-7	Connector << T >> R1/2" for pipe of 8 mm	1
	940 384	Cylindrical bolt M6x45 DIN-912	4
	941 306	Cap nut M6 DIN-917	4
	960 306	Stauff clamp G3/4"	2
8	843 505	Drum stop	1
	940 840	Flat-headed bolt M10x20 DIN-603	1

Pos.	Part No.	Description	Qty.
9	839200-2	Pneumatic cylinder	1
10	839200-9	Straight bulkhead connector for pipe of 6 mm	2
	839200-10	Straight bulkhead connector for pipe of 8 mm	1
11	931 250	Extendible hose ES 4x6x2 B (Blue)	1
	931250.001	Extendible hose ES 4x6x2 Y (Yellow)	1
12	931 251	Extendible hose ES 5,5x8x5 A	1
13	839 415	Fixing tank	1
	839 416	Tightening shaft, fixing drum	1
	839 419	Drum fixing handle	1
	941 542	Threaded python M10x15 DIN-913	1
14	531 420	B.N.G. PM45 40:1	1
	940 040	Screw M10X16 DIN-933	3
15	531 720	B.N.G. PM45 70:1	1
	940 040	Screw M10X16 DIN-933	3
16	532 820	B.N.G. PM60 80:1	1
	940 040	Screw M10X16 DIN-933	3
17	243 504	Hose 12x8 - M3/8" G. LENGTH = 4 m	1
	945 556	Connection reducer R1/2" R3/8" MH	1
	946 605	Steel and elastomer gasket J-12	1
	842 492	Adapter PM45 80:1 plato s.	1
18	842 500	Adaptor gasket	1
	940 334	Cylindrical bolt M8x20 DIN-912	6
	941 542	Threaded nozzle M10x15 DIN-913	2
	945 100	Plug DIN-908-1/4" BSP	1
	946 112	O-ring 50x3,5 Viton 90 shore-A	1
19	931 206	Polyurethane flexible tube D. 8x6 black	5 m
20	931 204	Polyurethane flexible tube D. 6x8 black	3,5 m

Troubleshooting

Symptoms	Possible Reasons	Solutions
The pump is not working or there is no fluid delivery.	No suitable air supply pressure.	Increase the air supply pressure.
	Some outlet circuit element is clogged or closed.	Clean or open the outlet circuit.
	Air between the follower plate and the grease.	Bleed the air.
The pump begins to operate very fast.	The drum is empty or the grease level is beneath the suction tube inlet.	Replace the drum.
The pump keeps on operating although the grease outlet is closed.	There is a grease leakage in some point of the circuit.	Verify and tighten or repair.
Grease leakage through the air outlet muffler.	Grease has passed over to the air motor caused by worn or damaged packing set.	Replace the packing set (repair kit).
Air leakage through the air outlet muffler.	The O-rings of the distributor axle or the bushing worn or damaged.	Replace the axle assembly and/ or the bushing assembly.
	The inverter O-rings are worn or damaged.	Replace the inverter O-rings.
Decrease of the grease delivery.	Dirt in upper valve or foot valve.	Dismount and clean, replace if damaged.
	Dirt in muffler.	Clean or replace the muffler.
The pump doesn't lift even without the pail.	The actuator is not working with proper pressure.	Regulate the pressure in the actuator with its control with a pressure higher than 2 bar.
Leakage between the follower plate adaptor and the pump's tube or between the follower plate and the adaptor.	The seals are damaged.	Replace the seals from the follower plate assembly.

2018_06_06-820

Area with horizontal dotted lines for writing notes.

2018_06_06-820

Declaración de conformidad

EN

SAMOA INDUSTRIAL, S.A., Pol. Ind. Porceyo, I-14 · Camino del Fontán, 831 · 33392 - Gijón - Spain, declares that the product(s):
conform(s) with the EU Directive(s):
2006/42/EC

ES

SAMOA INDUSTRIAL, S.A., Pol. Ind. Porceyo, I-14 · Camino del Fontán, 831 · 33392 - Gijón - España, declara que el(los) producto(s):
cumple(n) con la(s) Directiva(s) de la Unión Europea:
2006/42/CE

FR

SAMOA INDUSTRIAL, S.A., Pol. Ind. Porceyo, I-14 · Camino del Fontán, 831 · 33392 - Gijón - Espagne, déclare que le(s) produit(s):
est(sont) conforme(s) au(x) Directive(s) de l'Union Européenne:
2006/42/CE

DE

SAMOA INDUSTRIAL, S.A., Pol. Ind. Porceyo, I-14 · Camino del Fontán, 831 · 33392 - Gijón - Spanien, bestätigt hiermit, dass das (die)
Produkt (e):
den(die) EG-Richtlinie(n):
2006/42/EG
entspricht (entsprechen).

PT

SAMOA INDUSTRIAL, S.A., Pol. Ind. Porceyo, I-14 · Caminho de Fontán, 831 · 33392 - Gijón - Espanha, declara que os produtos cumprem
as diretrizes da União Europeia:
2006/42/CE

Revisions:

B - Added California Proposition 65 to
Warnings

For SAMOA INDUSTRIAL, S.A.
Por SAMOA INDUSTRIAL, S.A.
Pour SAMOA INDUSTRIAL, S.A.
Für SAMOA INDUSTRIAL, S.A.
Por SAMOA INDUSTRIAL, S.A.



Pedro E. Prallong Álvarez

Production Director
Director de Producción
Directeur de Production
Produktionsleiter
Diretor de Produção