

Balcrank

1/2" DOUBLE DIAPHRAGM PUMP CF10 (10 gal/min)
 1/2" DOUBLE DIAPHRAGM PUMP CF15 (14 gal/min)
 1" DOUBLE DIAPHRAGM PUMP CF30 (28 gal/min)

Operation and maintenance
 manual

CF10 CF15 CF30
 CODES: 1120-029A 1120-025A 1120-040
 1120-034A 1120-027 1120-026A
 1120-023A 1131-031A

Technical data	1
Warnings and cautions	2
Description	3
Capacity curves	4
Dimensions	5
Installation	6
Operating instructions	7
Exploded views:	
CF10	8
CF15 Polypropylene	9
CF15 Metallic	10
CF30 Metallic	11
CF30 Polypropylene	12
Repair kits / Wetted parts	13
Troubleshooting	14
Maintenance guide	16

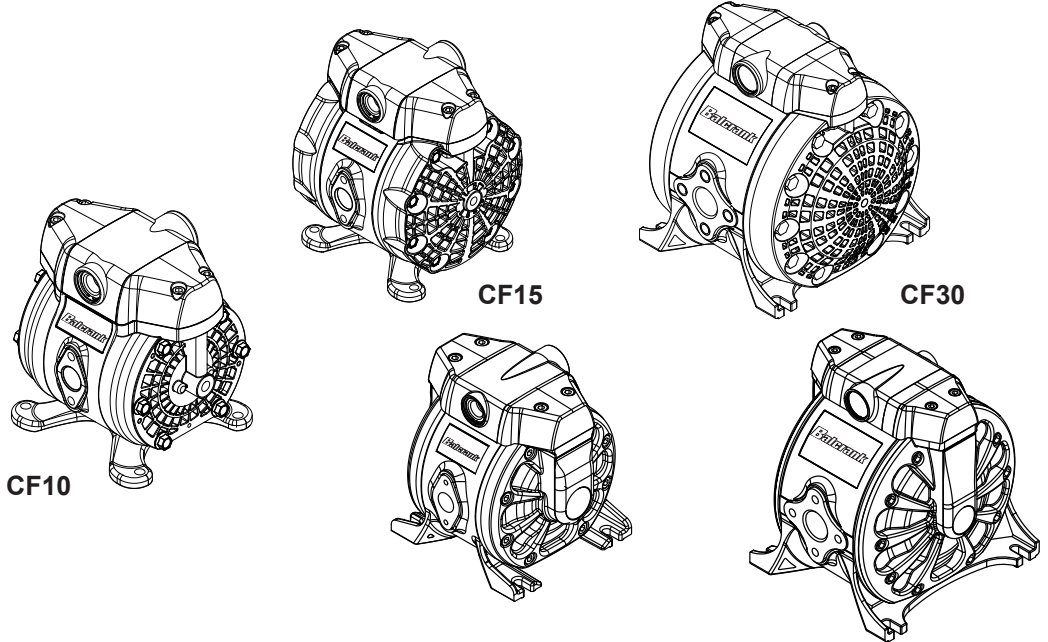

Technical data

	CF10	CF15	CF30
Ratio	1:1	1:1	1:1
Maximum free flow	10 gal/min (38 l/min)	13.2 gal/min (50 l/min)	26.4 gal/min (100 l/min)
Delivery per stroke	2.37 oz (0,07 l)	3.38 oz (0,1 l)	32 oz (0,25 l)
Air pressure operating range	43.51 to 100 psi (3 a 7 bar)	43.5 psi - 100 psi (3 a 7 bar)	43.5 psi - 100 psi (3 a 7 bar)
Solid in suspension max size	0.12 in (3 mm)	0.12 in (3 mm)	0.16 in (4 mm)
Maximum suction head	13.2 ft (4 m) dry 26.25 ft (8 m) wet	19.69 ft (6 m) dry 26.25 ft (8 m) wet	14.76 ft (4,5 m) dry 22.97 ft (7 m) wet
Weight	4.85 lb (2, 2 kg)	7.72 lb (3,5 kg) metallic 6.17 lb (2,8 kg) plastic	15.87 lb (7,2 kg) metallic 14.33 lb (6,5 kg) plastic
Fluid inlet (single inlet)	1/2" NPT (F)	1/2" NPT (F) and flange 1/2" BSP (F) and flange-DEF	1" NPT (F) and flange 1" BSP (F) and flange-DEF
Fluid outlet	1/2" NPT (F)	1/2" NPT (F) and flange 1/2" BSP (F) and flange-DEF	1" NPT (F) and flange 1" BSP (F) and flange-DEF
Air inlet	3/8" NPSM (F)	3/8" NPSM (F)	3/8" NPSM (F)
Wetted materials	See model specifications	See model specifications	See model specifications
Noise level	80 db	80 db	80 db
Temperature range (see material temperature range on page 3)	0 - 158 °F (0 - 70 °C)	0 - 158 °F (0 - 70 °C)	0 - 158 °F (0 - 70 °C)

2021_2_18-4-43

Product customization

* (oz,ft,gal/min) all in EEUU units

REV E. 7/24 SB 1145 1

Warnings and cautions

In this document you will find warnings and cautions for installation, use and maintenance of the Centerflo pumps.

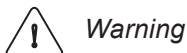

Warning

This symbol, be aware that there is a danger of serious bodily injury or death if you ignore the warning described.

Here's the meaning of symbols you may find in this document and general warnings that you should keep in mind.

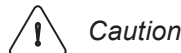

Caution

This symbol, be aware that there is a danger of personal injury or property damage if you ignore the caution described.

	WARNING
<p>DANGER: Not for use with fluids that have a flash point below 100°F (38°C). Examples: gasoline, alcohol. Sparking could result in an explosion which could result in serious injury or death.</p>	

CAUTION
<p>Pressure variations can cause vibration in piping systems. Connect the pump to the piping system using flexible hoses. Ensure pipes and fittings are properly secured to their supports. Do not use the pump as part of the support structure of the piping system.</p>

	WARNING
<p>In the presence of explosive vapors, take action to prevent static sparking. Failure to ground the pump, piping, valves, containers, or other miscellaneous equipment can result in fire or explosion.</p>	

	WARNING
<p>Do NOT use with solvents or other explosive fluids.</p>	

CALIFORNIA PROPOSITION 65
<p>This product contains a chemical known to the State of California to cause cancer, birth defects or other reproductive harm. Wash hands after handling</p>



Warning

Carefully read the instructions and warnings before operating the equipment!

- This equipment is for professional use only.
- Do not degrade the integrity of the equipment. Use only original replacement components from Balcrank Corporation.
- Fluids not suitable for the pump can cause damage to the pump unit and involve risk of serious personal injury.
- Consult Balcrank Corporation if you have any questions about the wetted materials of the pump, and always check compatibility of the fluids, and the pump materials, including elastomers with the fluid supplier.
- Install and use the pump according to all local and national regulations and abide all health and safety laws or legislation.
- The pump can produce fluid pressures equal to the air supply pressure. Do not exceed the maximum allowable pressure of 100 psi (7 bar) air supply. The total hydraulic pressure (differential pressure + system) should never exceed 100 psi (7 bar).
- Never use a pump that leaks, that is damaged, that is corroded or otherwise it may lack the capacity to contain the fluid.
- Frequently check that the bolts on the diaphragm covers of the pump to ensure they are torqued correctly (see page 14 for torque specifications).
- Do not use a model with aluminium wetted surfaces to pump fluids for human consumption, there is a possibility of trace contamination of lead.
- Danger of explosion if used 1,1,1-trichloroethane, methylene chloride or other halogenated hydrocarbon solvents with aluminium wetted materials. It could cause serious injury and property damage.
- Inside the pump, diaphragms separate the fluid that is being pumped from the air supply. If a diaphragm breaks, the fluid can leak out of the air exhaust and contaminate the environment.
- When handling hazardous fluids, always route the air exhaust into a suitable container and locate it in a safe place.
- When the fluid source level is situated higher than the pump, (flooded suction), the outlet tank must be at a higher level than the product to prevent spills.
- For pumps handling hazardous fluids that are a danger to humans or to the environment, install a suitable container surrounding the pump to prevent any leaks or spills.
- Ensure that the operators of this equipment are trained on the operation and limitations. Use safety equipment such as safety goggles or other equipment required.

2021_2_18-4:43

Description

Air operated double diaphragm pumps are air-powered, reciprocating positive displacement pumps with two pumping chambers. Two diaphragms, centrally located in the chambers, separate the compressed air (dry side) from the fluid being pumped (wet side). A shaft transmits the reciprocating motion of one diaphragm to the other. A directional valve alternatively distributes the air from one chamber to the other; thus a reciprocating movement of the diaphragms is created. With each stroke, fluid is discharged by one of the diaphragms whilst the opposite diaphragm sucks new fluid into the expanding chamber. Check valves, two on the discharge side and two on the suction side, control and direct the fluid flow.

Material	Temperature range
PTFE	5 °C - 105 °C / 41 °F - 221 °F
NBR	10 °C - 80 °C / 50 °F - 176 °F
Acetal	10 °C - 90 °C / 50 °F - 194 °F
Hytrel®	10 °C - 90 °C / 50 °F - 194 °F
Neopreno	-18 °C - 93 °C / 0 °F - 200 °F
Santoprene®	-29 °C - 135 °C / -20 °F - 275 °F
Viton®	-10 °C - 120 °C / -4 °F - 248 °F
Polypropylene®	10 °C - 80 °C / 50 °F - 176 °F

Capacity curves

CF10

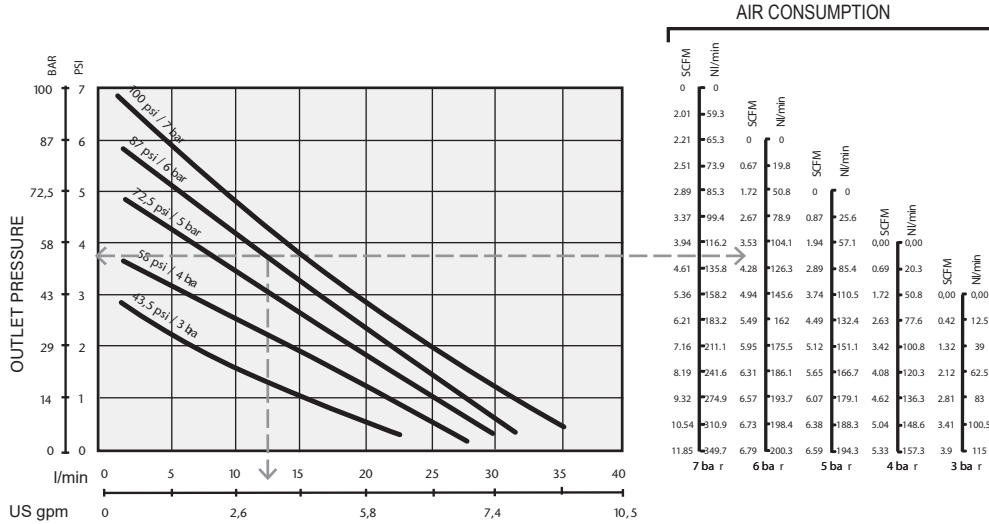

CF15

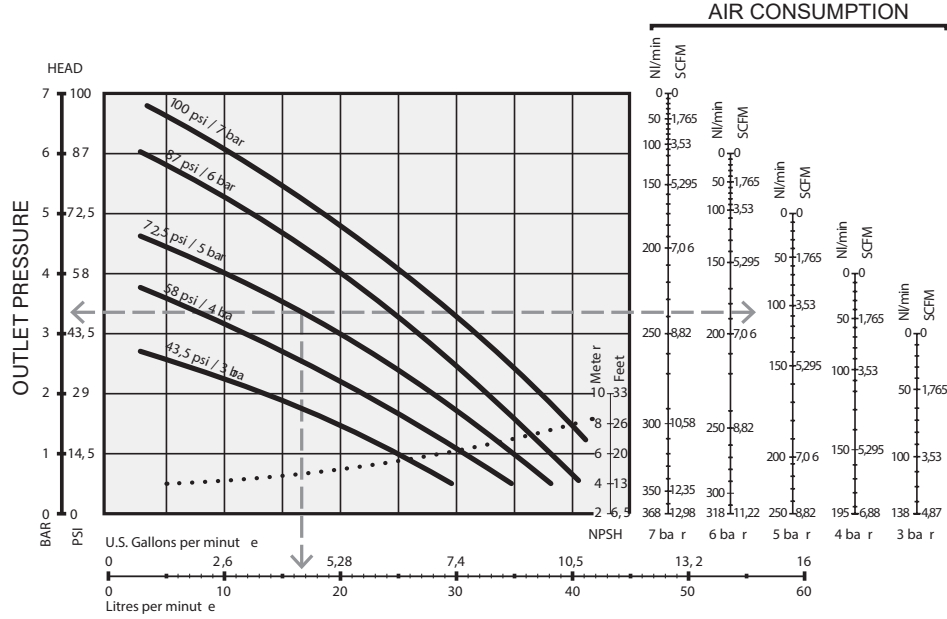

CF30

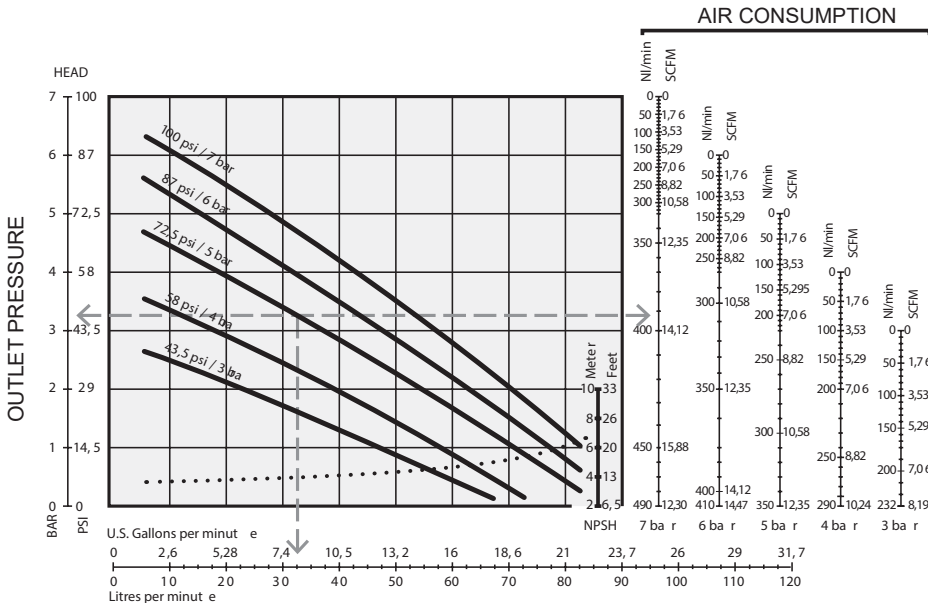

*Tested at room temperature, using water. Flooded pump with 3.5 inches, (80 mm), positive suction head.

Dimensions

CF10												
A	B	C	D	E	F	G	I	J	K	L	N	P
5.12"	6.3"	6.38"	4.13"	4.8"	0.31"	5.51"	2.76"	1/2" NPT	5.71"	3/8" NPSM	M6	1.61"
130 mm	160 mm	162 mm	105 mm	122 mm	8 mm	140 mm	70 mm		145 mm			41 mm

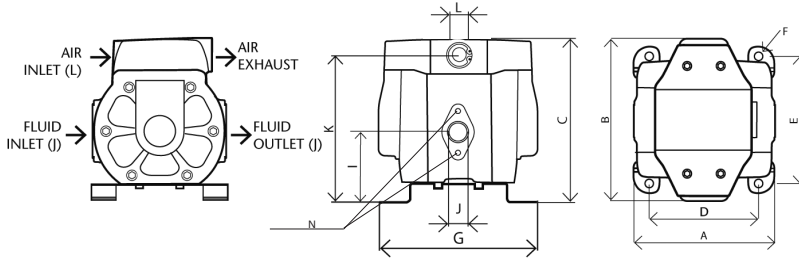

CF15						
A	B	C	D	E	F	G
6.14"	6.3"	6.57"	4.13"	4.8"	0.31"	5.75"
156 mm	160 mm	167 mm	105 mm	122 mm	8 mm	146 mm
I	J	J	K	L	M	N
2.76"	1/2" NPT	1/2" BSP	5.91"	3/8" NPSM	0.94"	M6
70 mm	1120-023A 1120-027	1120-025A	150 mm		24 mm	

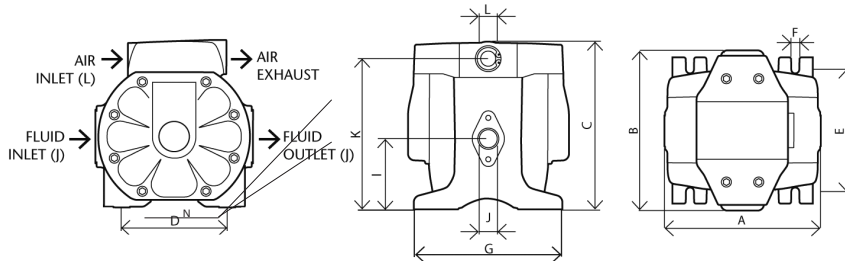

CF30											
A	B	C	D	E	F	G	I	J	J	K	L
8.5"	7.44"	8.94"	6.89"	6.06"	0.35"	7.24"	3.72"	1" NPT	1" BSP	8.27"	3/8" NPSM
216 mm	189 mm	227 mm	175 mm	154 mm	9 mm	184 mm	94,51 mm	1120-040 1120-026A	1120-031A	210 mm	

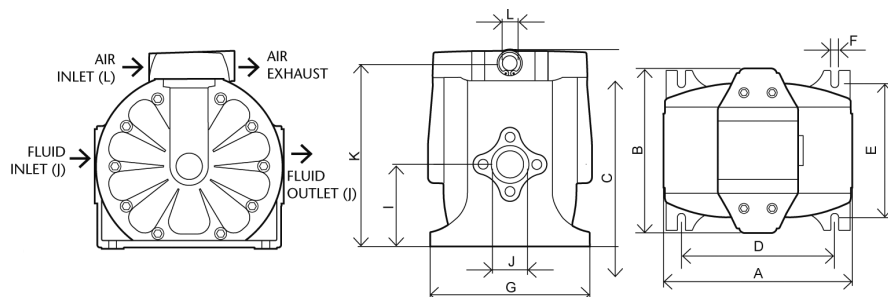

Installation

Installation recommendations

- Remove the pump from its package and install it on the chosen location.
- Try to minimize the suction head. Install the pump as close as possible to the fluid being pumped.
- Remember to have enough space around the pump to perform maintenance tasks.
- Keep in mind to connect the inlet and outlet of the pump correctly.
- In case of diaphragm failure, the air exhaust will expell the product being pumped.
- When the pump is installed in a place where a spill of fluid can cause an environmental impact, the exhaust should be directed to a place where this spill could be contained.
- When installing the pump in its place, use brackets to secure its base.
- Prior to operation, tighten all bolts according to the torques contained in this manual (see page 16).

CF pumps are very easily configured and easy to install.
Flooded:

The pumping system was designed with positive pressure at the inlet. This is the best possible installation when you need to evacuate the liquid from the drum or tank, or when working with viscous fluids. Not recommended for hazardous fluids.

Self-priming:

Pump is designed to generate vacuum. It is possible to evacuate all the air from a hose or pipe without damaging the pump. Maximum suction height is 19.69 ft (6 m), with the suction hose empty and up to 26.25 ft (8 m) with the hose primed. (See page 1 for corresponding suction lift).

Submerged:

All pumps can be immersed in fluids. It is important to verify that all components that are in contact with the fluid are chemically compatible. In this case, air exhaust and fluid must be carried by hoses (optional air connection).

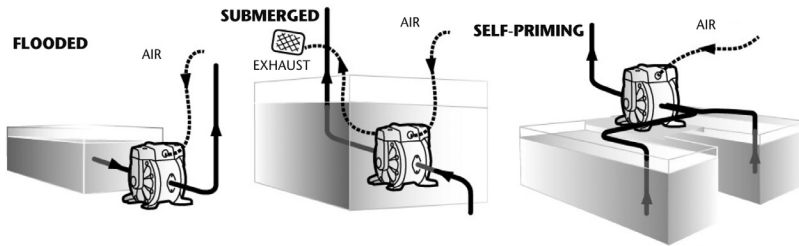

NOTE: Use a pressure regulator with built-in filter inlet.

NOTE: The compressed air supply must be between 43.5 psi (3 bar) and 100 psi (7 bar).

Recommended installation

The figure below shows the recommended configuration for the installation of a diaphragm pump. Read the warnings and recommendations of the previous page before starting.

Model	Fluid Inlet Hose	Fluid Outlet Hose
CF10	> =1/2"	> =1/2"
CF15	> =1/2"	> =1/2"
CF30	> =1"	> =1"

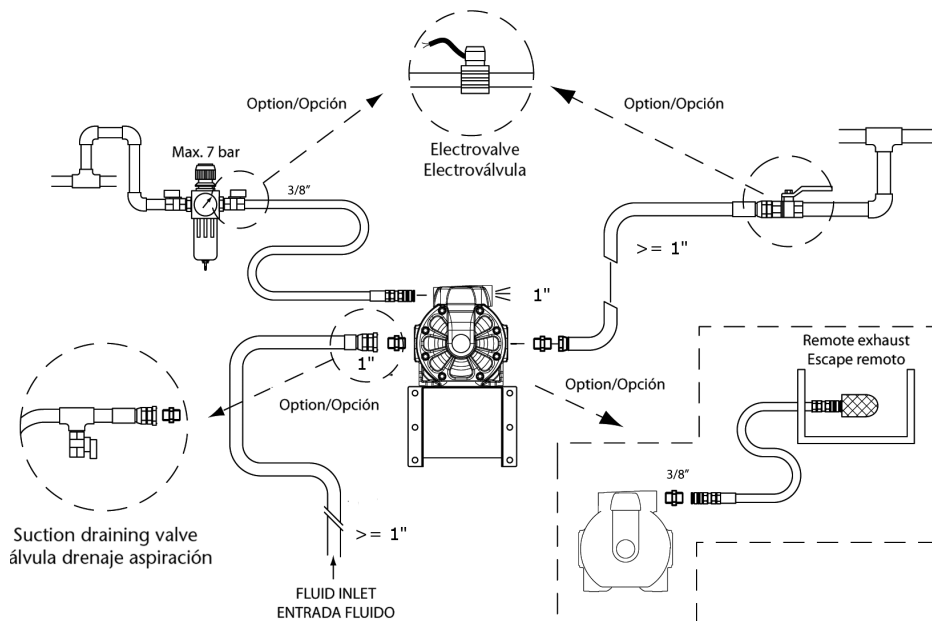

2021_2_18-4-43

Installation



Warning

Air connection

To ensure that the air supply is sufficient to meet the demand of the pump, the diameter of the pipe must be equal to the diameter of the supply port of the pump. Choose auxiliary air treatment equipment and fittings with sufficient airflow to exceed the air consumption of

the pump. In addition, peripheral air treatment equipment must be installed as close as possible to the pump unit.

The use of a coupler to connect the hoses aids future operation and maintenance tasks.

Operating instructions

This pump is self-priming.

To prime it the first time, you must connect the air pump supply at a low pressure using the pressure regulator while keeping the outlet valve open. Slowly increase the air pressure until fluid begins to flow from the pump outlet, and the desired fluid flow is achieved.

When fluid begins to flow from the pump outlet, the pump is primed. For regulation of fluid pressure, the unit must be supplied with an air pressure between 43.5 and 100 psi (3 and 7 bar). Adjust the discharge valve on the discharge side to control flow. For the performance characteristics of the pump see the capacity curve shown on page 4.

Stopping the pump

- Close the inlet valve of the pump and stop the air supply.
- Make sure for your safety that the air valve is closed.
- Turn off the air compressor, or close the valve on the air supply side of the auxiliary equipment.
- Close the discharge valve on the discharge side, then begin to slowly open the drain valve and discharge pressure fluid.
- Open the air valve of the pump, turn on the pump and flush the remaining fluid.
- After ensuring that the pump was turned off and the pressure was released, fully open and close the regulator valve and drain valve of the pump.

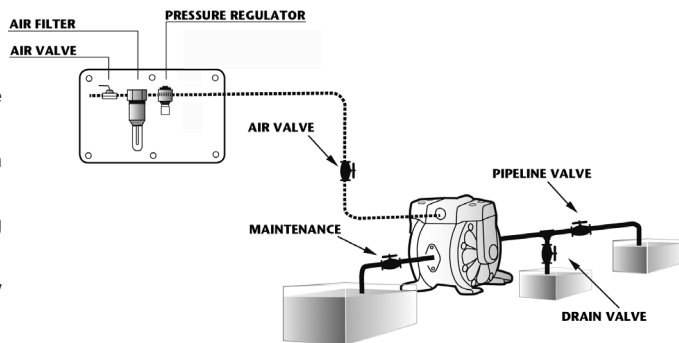

Grounding the pump

- When installing the pump, be sure to perform grounding in the specified location.
- Also connect ground wires for the auxiliary equipment and piping.
- Use a grounding cable of at least 12 gauge (2.0 mm²).
- If the pump you have purchased is valid for Atex, a specific Atex manual will accompany this one. Read this manual before operating the pump.
- If the unit is marked with the symbol,  it can be used in potentially explosive atmospheres. Below this symbol, in the nameplate of the pump, are indicated the areas for which the equipment is approved. You will also find the maximum allowable surface temperature in the same plate.

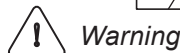
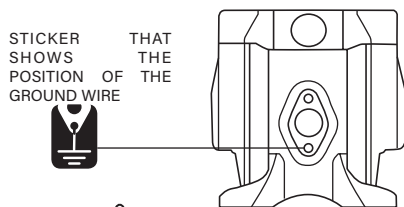

Warning

- Connect grounding wires to the pump, piping and all other equipment too.
- When the pump operates ungrounded or with an incorrect connection, friction between parts and abrasion caused by some fluids that flow inside the pump, can generate static electricity. Moreover, according to the type of fluid pump and the installation environment (such as gases in the air or the type of the surrounding facilities) static electricity can cause fire or electric shock.

Parts

CF10

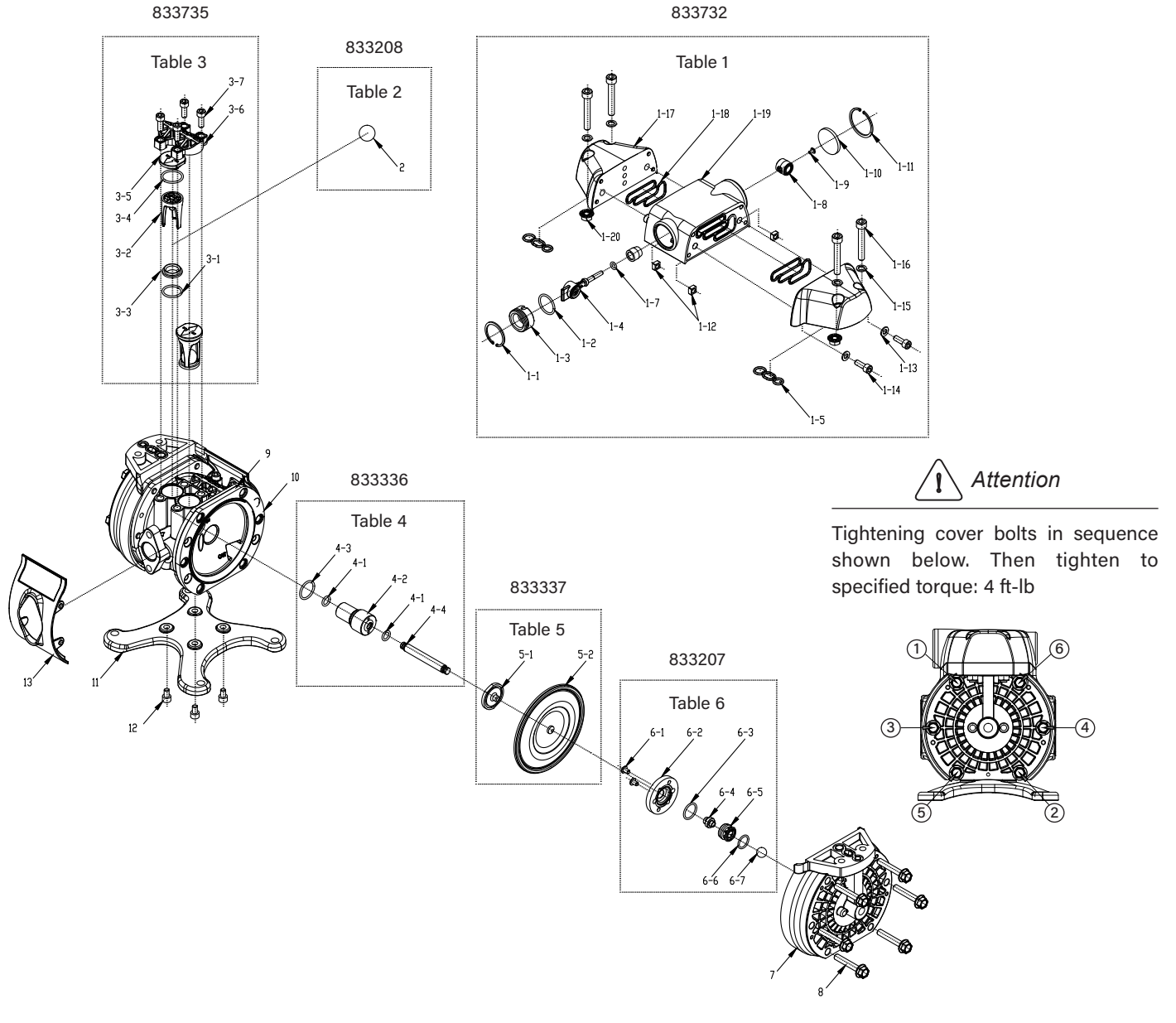

Attention

Tightening cover bolts in sequence shown below. Then tighten to specified torque: 4 ft-lb

No.	Code	Description	Qty.	Notes
1	See table 1	Air Valve	1	1-1 through 1-20. Assembled and verified
2	See table 2	Check Ball	4	2
3	See table 3	Ball Seat, O-rings and Ball Guide	4	3-1 through 3-7
4	See table 4	Bushing, O- rings and Push Rod	1	4-1 through 4-4
5	See table 5	Diaphragms	2	5-1 through 5-2. Assembled
6	See table 6	Stroke sensor	1	6-1 through 6-7.
7	Not Available	Diaphragm cover	2	Contact BALCRANK for assistance. Not sold as repair kit
8		Diaphragm cover bolts	12	
9		Diaphragm cover washers	4	
10		Body	1	
11		Pump support	1	
12		Support bolts	4	
13		Pump Shields	2	

2021_2_18-4:43

CF15 Polypropylene

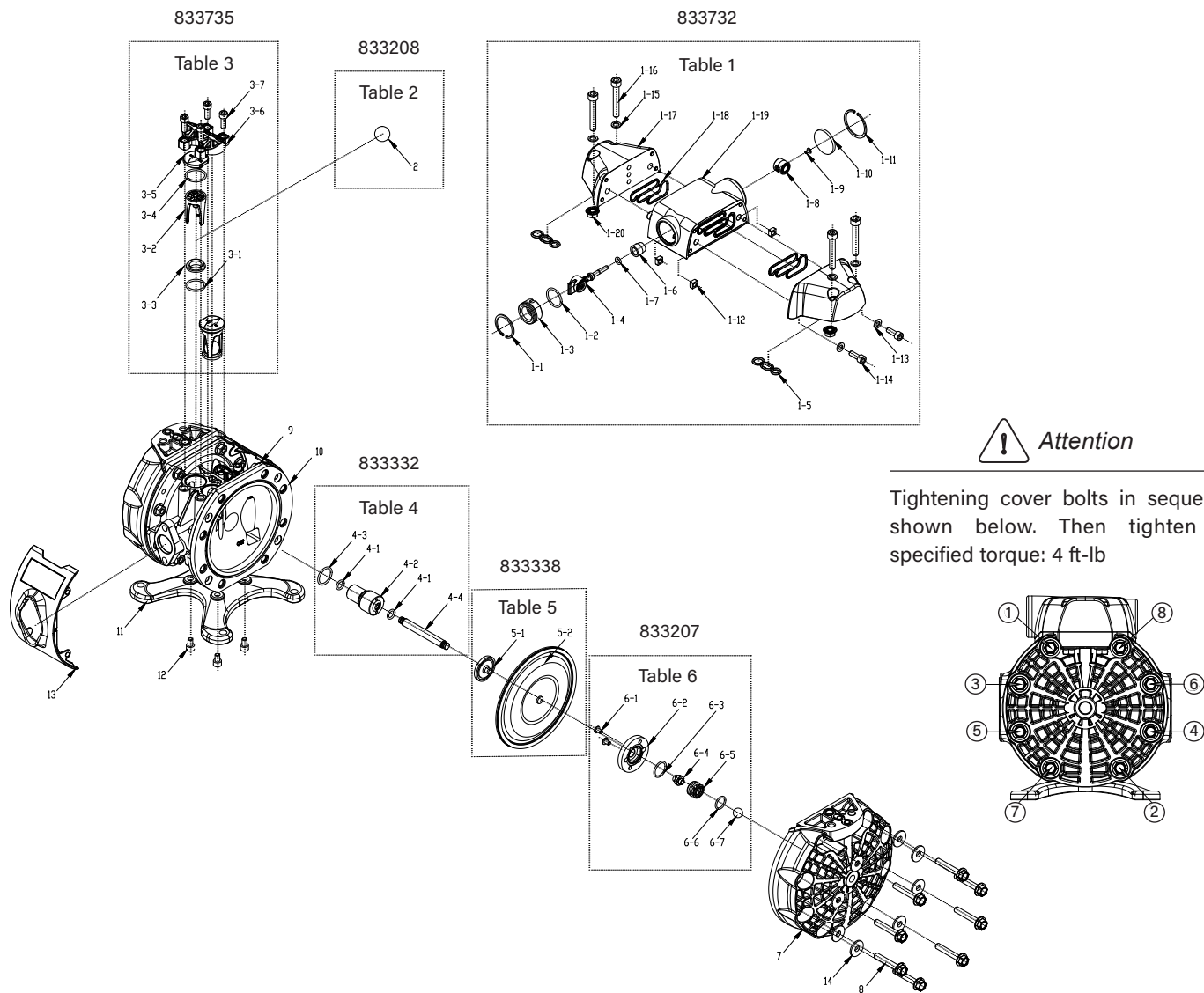

Attention

Tightening cover bolts in sequence shown below. Then tighten to specified torque: 4 ft-lb

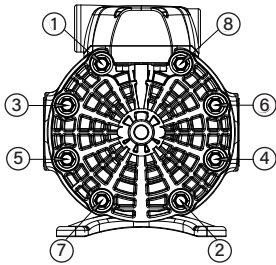

No.	Code	Description	Qty.	Notes
1	See table 1	Air Valve	1	1-1 through 1-20. Assembled and verified
2	See table 2	Check Ball	4	2
3	See table 3	Ball Seat, O-rings and Ball Guide	4	3-1 through 3-7
4	See table 4	Bushing, O- rings and Push Rod	1	4-1 through 4-4
5	See table 5	Diaphragms	2	5-1 through 5-2. Assembled
6	See table 6	Stroke sensor	1	6-1 through 6-7
7	Not Available	Diaphragm cover	2	Contact BALCRANK for assistance. Not sold as repair kit
8		Diaphragm cover bolts	16	
9		Diaphragm cover washers	4	
10		Body	1	
11		Pump support	1	
12		Support bolts	4	
13		Pump Shields	2	
14		Cover washers	16	

2021_2_18-4:43

CF15 Metallic

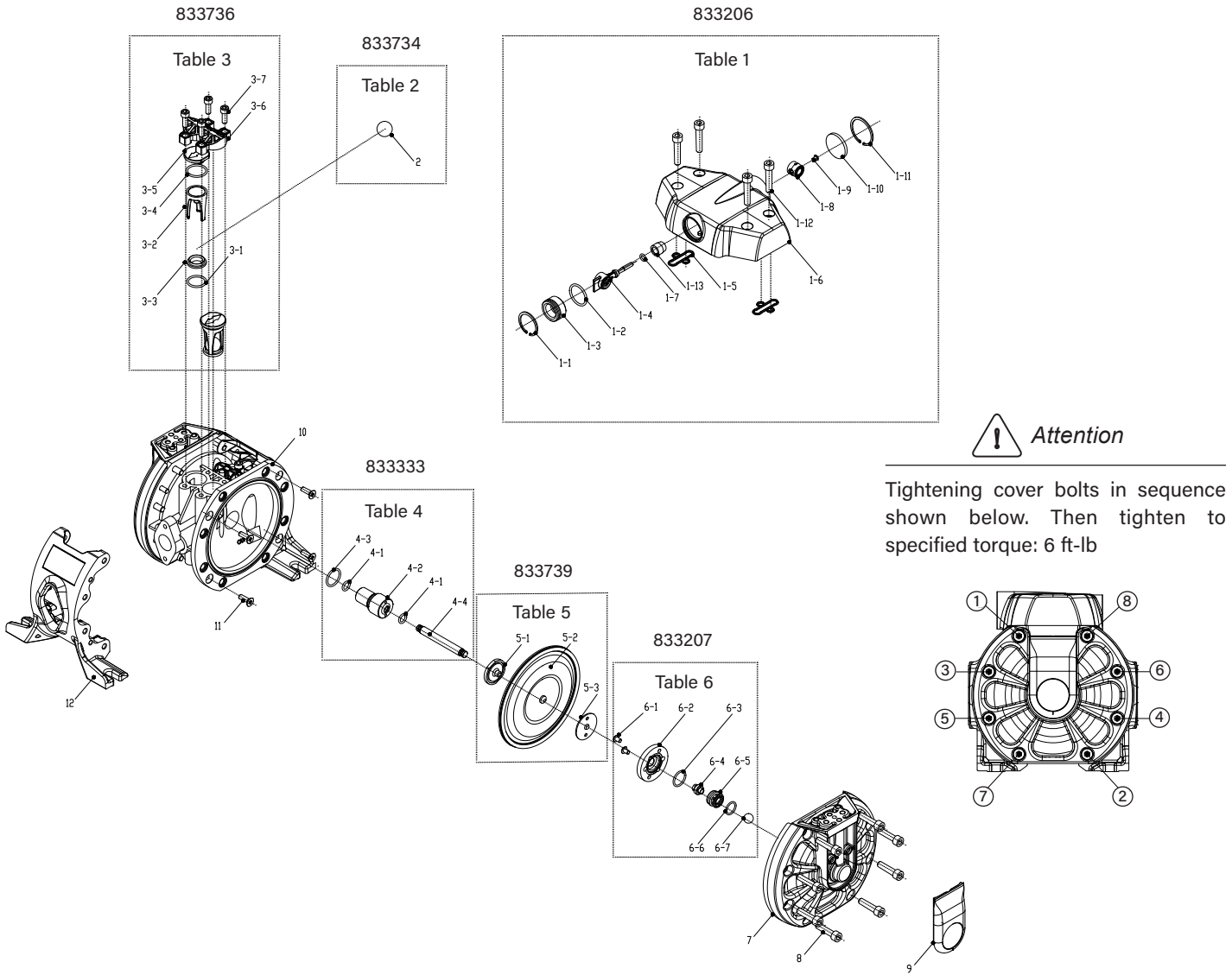

No.	Code	Description	Qty.	Notes
1	See table 1	Air Valve	1	1-1 through 1-13. Assembled and verified
2	See table 2	Check Ball	4	2
3	See table 3	Ball Seat, O-rings and Ball Guide	4	3-1 through 3-7
4	See table 4	Bushing, O- rings and Push Rod	1	4-1 through 4-4
5	See table 5	Diaphragms	2	5-1 through 5-3. Assembled
6	See table 6	Stroke sensor	1	6-1 through 6-7
7	Not Available	Diaphragm cover	2	Contact BALCRANK for assistance. Not sold as repair kit
8		Diaphragm cover bolts	16	
9		Cover	2	
10		Body	1	
11		Pump shield bolts	4	
12		Pump shield	2	

2021_2_18-4:43

CF30 Metallic

No.	Code	Description	Qty.	Notes
1	See table 1	Air Valve	1	1-1 through 1-12. Assembled and verified
2	See table 2	Check Ball	4	2
3	See table 3	Ball Seat, O-rings and Ball Guide	4	3-1 through 3-7
4	See table 4	Bushing, O- rings and Push Rod	1	4-1 through 4-4
5	See table 5	Diaphragms	2	5-1 through 5-3. Assembled
6	See table 6	Stroke sensor	1	6-1 through 6-7
7	Not Available	Diaphragm cover	2	Contact BALCRANK for assistance. Not sold as repair kit
8		Diaphragm cover bolts	20	
9		Cover	2	
10		Body	1	
11		Pump shield bolts	7	
12		Lower shield	1	
13		Upper shield	1	

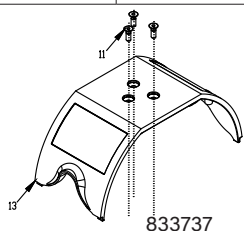

833737

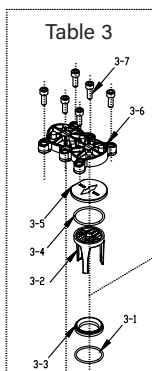
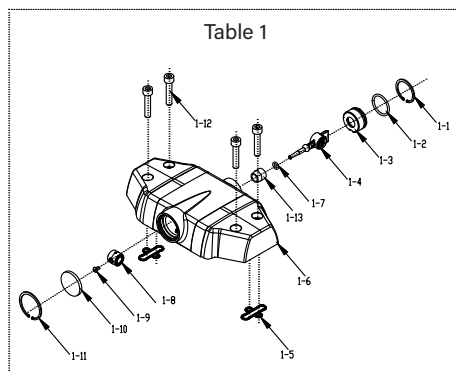

Table 3

833656

Table 2



833212

Table 1



Attention

Tightening cover bolts in sequence shown below. Then tighten to specified torque: 11 ft-lb

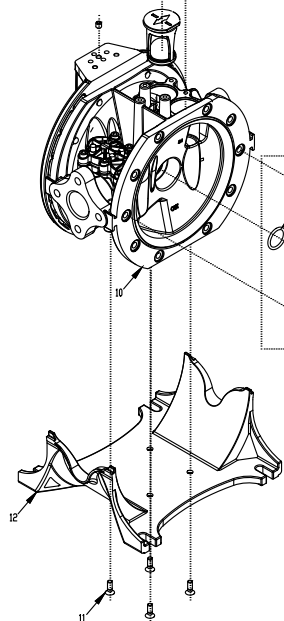
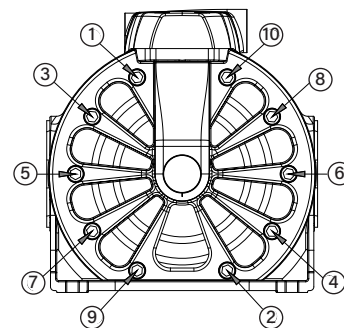

833657

Table 4

833658

Table 5

833207

Table 6

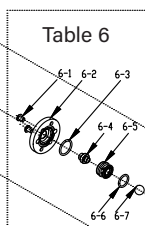
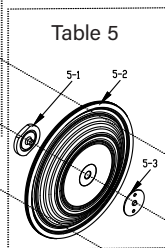
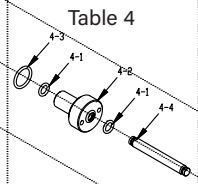

2021_2_18-4-43

Pumps repair kit codes

Pump		Table 1 - Air Valve		Table 2 - Check Ball		Table 3 - Ball Seat / Seal / Cage	
Size	Item	Material	Item	Material	Item	Material	Item
CF10	1120-029A	Polypropylene	833732	PTFE	833208	SS / Viton / Polypropylene	833735
	1120-034A	Polypropylene	833732	PTFE	833208	SS / Viton / Polypropylene	833735
CF15	1120-023A	Polypropylene	833732	PTFE	833208	SS / Viton / Polypropylene	833735
	1120-025A	Polypropylene	833732	PTFE	833208	SS / Viton / Polypropylene	833735
	1120-027	Standard	833206	Buna-N	833734	SS / Buna-N / Acetal	833736
CF30	1120-040	Standard	833212	Hytrel	833656	SS / Buna-N / Acetal	833737
	1120-026A	Polypropylene	833733	PTFE	833233	SS / Viton / Polypropylene	833738
	1120-031A	Polypropylene	833733	PTFE	833233	SS / Viton / Polypropylene	833738

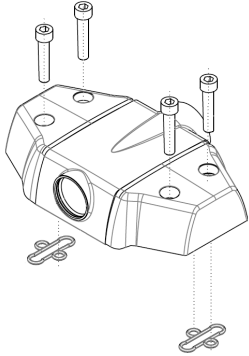

x1

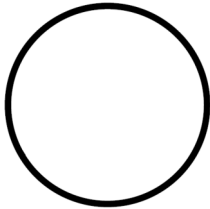

x4

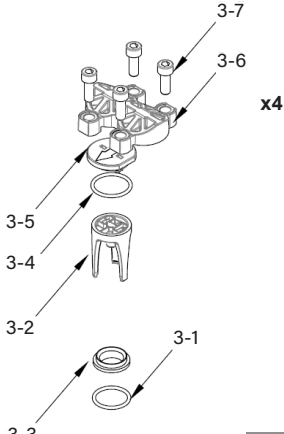

x4

Pump		Table 4 - Bushing / Seals / Rod		Table 5 - Diaphragms		Table 6 - Stroke Sensor	
Size	Item	Material	Item	Material	Item	Material	Item
CF10	1120-029A	PTFE / Viton / SS	833336	Hytrel, SS	833337	Aluminum, Bronze, Buna-N, SS	833207
	1120-034A	PTFE / Viton / SS	833336	Hytrel, SS	833337	Aluminum, Bronze, Buna-N, SS	833207
CF15	1120-023A	PTFE / Viton / SS	833332	Hytrel, SS	833338	Aluminum, Bronze, Buna-N, SS	833207
	1120-025A	PTFE / Viton / SS	833332	Hytrel, SS	833338	Aluminum, Bronze, Buna-N, SS	833207
	1120-027	PTFE / Buna-N / SS	833333	Buna-N, SS	833739	Aluminum, Bronze, Buna-N, SS	833207
CF30	1120-040	PTFE / Buna-N / SS	833657	Buna-N, SS	833658	Aluminum, Bronze, Buna-N, SS	833207
	1120-026A	PTFE / Viton / SS	833335	Hytrel, SS	833339	Aluminum, Bronze, Buna-N, SS	833207
	1120-031A	PTFE / Viton / SS	833335	Hytrel, SS	833339	Aluminum, Bronze, Buna-N, SS	833207

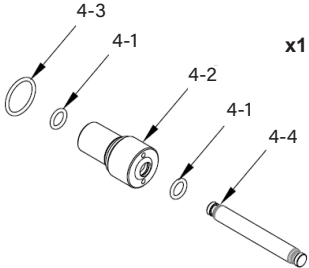

x1

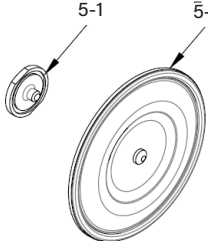

x2

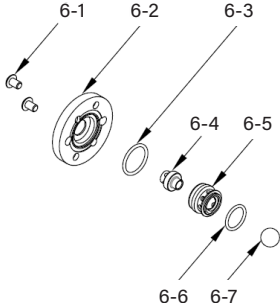

x2

2021_2_18-4:43

Troubleshooting

The pump does not work.	
Cause	Recommended measure
The discharge valve on the discharge side is not open.	Open the discharge valve on the discharge side.
No air supply.	Turn on the compressor and open the air valve and air regulator.
The air supply pressure is low.	Check the compressor and the configuration of the air line.
Air leaks in connecting elements.	Check the connection elements and the tightening of the screws.
The air pipes or ancillary equipment is clogged.	Check and clean the air line.
The exhaust port (muffler) of the pump is clogged.	Check and clean the exhaust port and muffler.
The fluid pipe is clogged.	Check and clean the fluid line.
Pump is clogged	Remove, inspect and clean the pump body.

The pump runs but no fluid comes out.	
Cause	Recommended measure
The valve on the suction side is not open.	Open the valve on the suction side.
Too much suction or discharge height.	Confirm the configuration of the pipe and reduce the height of the same.
Fluid pipe discharge side (including the filter) is clogged.	Check and clean the fluid line.
Pump is clogged.	Dismantle the pump, check and clean.
The ball and ball seat is worn or damaged.	Inspect and replace parts.

The flow is decreasing.	
Cause	Recommended measure
The air supply pressure is low.	Check the compressor and the configuration of the air line.
The air line or peripheral equipment clogged.	Check and clean the air line.
Valve discharge side drive will not open normally.	Adjust the discharge valve discharge side.
The air mixes with the fluid.	Replenish fluid and check the configuration of the pipe on the suction side.
Cavitation occurs.	Adjust air supply pressure and discharge pressure and reduce the suction.
Vibrations.	Adjust air supply pressure and discharge pressure. Reduce the flow of the inlet valve to adjust pressure and volume of fluid.
Ice formation in the air exhaust.	Remove ice from the air bypass valve and check and clean the air filter. Use a pipe in the exhaust air that the ice does not form in the muffler.
The fluid line (including the filter) clogged	Check and clean the fluid pipe and strainer.
The exhaust port (muffler) of the pump is clogged.	Check and clean the exhaust port and muffler.
Pump is clogged.	Remove, inspect and clean the pump body.

Leakage of fluid through the hollow exhaust (silencer).	
Cause	Recommended measure
The diaphragm is damaged.	Remove and inspect the pump and replace the diaphragm.

Irregular noise.	
Cause	Recommended measure
The air supply pressure is too high.	Adjust air supply pressure.
The pump is clogged with sludge particles larger than the diameter allowed.	Remove, check and clean the pump body.

Irregular vibration.	
Cause	Recommended measure
The elements of connection and the support of the pump are loose.	Review each element of connection and tighten the screws.
The air supply pressure is too high.	Adjust air supply pressure.
The range and ball valve vibrates.	Adjust air supply pressure and exhaust pressure.

Troubleshooting

Fluid is milky or has air bubbles.	
Cause	Recommended measure
Diaphragm damaged.	Replace diaphragm.
Suction hose loose or broken.	Tighten or replace.

Powered air leak pressure of 43.5 -100 psi (3 to 7 bar).	
Cause	Recommended measure
Wear directional valve.	Replace directional valve components.

No start-up and is leaking air without cycles.	
Cause	Recommended measure
Stiff air sensors.	Change air sensor.
Worn directional valve.	Replace.

2021_2_18-4:43

Torques necessary for the proper functioning of the pump

For proper operation of the pump and to prevent accidents which may damage equipment and in the worst case, people, you must PERIODICALLY REVIEW THE TORQUES OF THE DIAPHRAGMS COVERS AND THE DIRECTIONAL VALVE. In the next table are shown the appropriate torques for this purpose:

Pump		Air Valve	Diaphragm Cover	Valve Cap
Size	Item	Torque		
CF10	1120-029A	4 ft-lb (5 N.m)	4 ft-lb (5 N.m)	1.5 ft-lb (2 N.m)
	1120-034A	4 ft-lb (5 N.m)	4 ft-lb (5 N.m)	1.5 ft-lb (2 N.m)
CF15	1120-023A	4 ft-lb (5 N.m)	4 ft-lb (5 N.m)	1.5 ft-lb (2 N.m)
	1120-025A	4 ft-lb (5 N.m)	4 ft-lb (5 N.m)	1.5 ft-lb (2 N.m)
	1120-027	4 ft-lb (5 N.m)	6 ft-lb (8 N.m)	4 ft-lb (5 N.m)
CF30	1120-040	4 ft-lb (5 N.m)	11 ft-lb (15 N.m)	4 ft-lb (5 N.m)
	1120-026A	4 ft-lb (5 N.m)	11 ft-lb (15 N.m)	1.5 ft-lb (2 N.m)
	1120-031A	4 ft-lb (5 N.m)	11 ft-lb (15 N.m)	1.5 ft-lb (2 N.m)

Diaphragm replacement

Before any intervention: DISCONNECT AIR SUPPLY OF THE PUMP. IT IS NOT NECESSARY TO REMOVE THE PUMP FROM THE FLUID LINE.

1. Close fluid valves.
2. Drain the fluid inside the pump. Anticipate a drainage of fluid from inside the pump.
3. Remove the air valve while being careful not to damage the seals.
4. Remove the diaphragm cap.
5. Remove the cover by gently pulling back.
6. Remove the used diaphragm and place the new one in the proper position.
7. Assemble components.

NOTE: tightening cover bolts in sequence shown at spare parts section. A torque wrench must be used following the torques specification shown above.

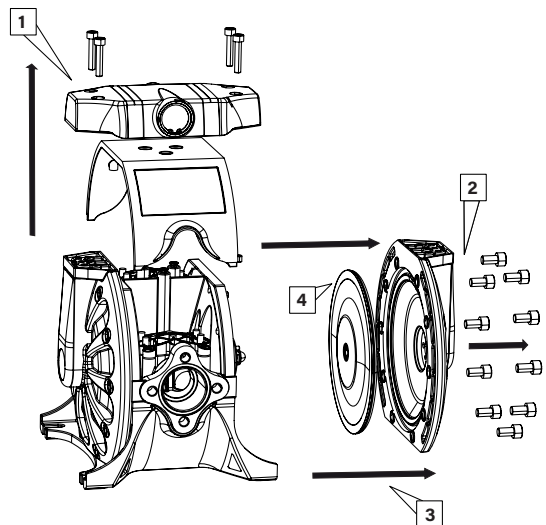

Pushing rod

Remove the side cover on the right of the fluid inlet as shown in the figure, following the procedure for "Diaphragm replacement".

Once the shaft is visible, use the following procedures:

1. Remove the shaft from its housing by pulling it from one end. The Teflon® sleeve is threaded into the body. To remove use snap ring pliers in the two holes indicated in the figure.
2. Once the sleeve has been removed, remove the quad ring inside the pump body.
3. Replace the kit following the correct order shown in the assembly drawing.
4. Reassemble the pump in reverse order.

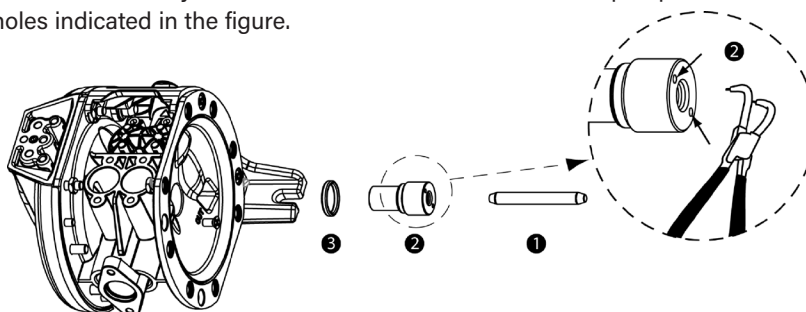

2021_2_18-4:43

Ball valves replacement

1. Close fluid valves.
2. Drain the fluid from inside the pump. Anticipate a drainage of fluid from inside the pump.
3. Loosen the screws to remove the directional valve. Take special care with the seals.
4. Remove the valve cover by loosening the screws with an Allen wrench. Take note of the orientation of the cap, as it is critical to replace it correctly during reassembly.



Attention

To avoid fluid restriction and leakages, follow the position of the ball checks guides in figure 1. The valves caps must be placed with the area indicated in the figure below facing the center of the pump body, shown in figure 2

5. Install a new set of valves according to these assembly drawings. Ensure that the ball guides are assembled as shown in the figure below, and tighten the screws with a maximum torque (see torque table page 16).
6. Assemble the directional valve being careful not to damage the O-rings and tighten the screws with a maximum torque of 4 ft-lb (5 N·m).

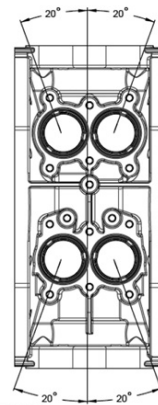

figure 1

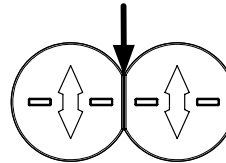
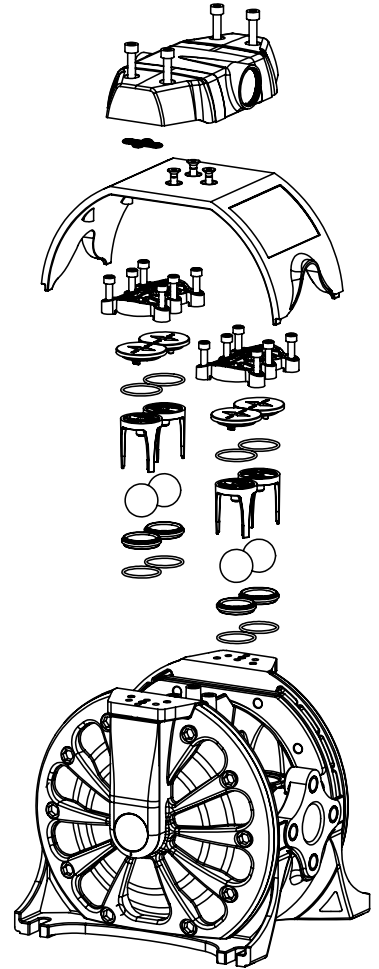

figure 2



Air sensor

The air sensors are on the inside part of the diaphragm covers. To access them, follow the procedure for "Diaphragm replacement".

Once the covers are removed follow the procedure below:

1. Remove the two screws that secure the air sensor to the top.
2. Remove all components of the sensor. Clean the area.
3. Install the new components in the order shown.
4. Fit the cover on the pump and tighten the screws to the body of the pump, with a maximum torque (see torque table page 14).
5. Fit the remaining components in reverse order.

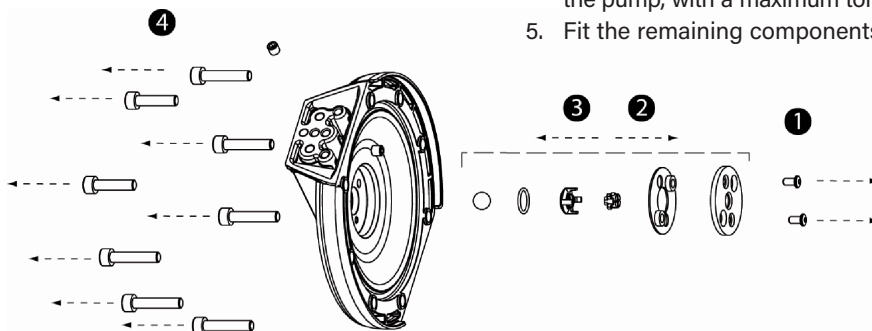

For warranty information visit:
www.balcrank.com

2021_2_18-4:43

Balcrank® Corporation
Weaverville, NC 28787
800-747-5300
800-763-0840 Fax
www.balcrank.com

Revision Log:

Rev. A - New release
replaces SB1121, SB1122, SB1123, SB1124

Rev. B - Product addition
1120-029A, 1120-034, 1120-025A, 1120-023A, 1120-028A, 1120-026A, 1120-031A

Rev. C - Replaced 1120-024 to 1120-040. Changed Buna to Hytrel in Wetted Materials for 1120-040

Rev. D - Replaced 1120-034 to 1120-034A.

Rev. E - Product subtraction
1120-028A