

Balcrank[®]

Signature PREMIUM™ Reels *Heavy Duty Transfer*

Model: 2111-XXX

See page 3 for Hose Reel Model
Numbers and Technical Data



Thoroughly read and understand this manual before
installing, operating or servicing this equipment.

**OPERATION, INSTALLATION,
MAINTENANCE AND REPAIR GUIDE**

General Safety

Thoroughly read and understand this manual before installing, operating or servicing this equipment.

	! IMPORTANT
	<p>Read these safety warnings instructions in this manual completely, before installation and start-up of the reel. It is the responsibility of the purchaser to retain this manual for reference. Failure to comply with the recommendations stated in this manual will damage the reel and void factory warranty.</p>

	! IMPORTANT
	<p>Because this Hose Reel can be incorporated into a pressurized systems, the following safety precautions should be observed.</p> <p>Check equipment regularly and repair or replace worn and damaged parts.</p> <p>Never alter or modify any parts of this hose reel, doing so may cause damage to hose reel and/or personal injury.</p> <p>Under no circumstances should the dispensing valve be aimed at any person at any time. Personal injury may result.</p> <p>Release pressures built up in the system before any service or repair is begun. See the pressure relief procedure below.</p> <p>Always read and follow the fluid manufacturer's recommendations regarding the use of protective eyewear, clothing and respirators.</p>

	! WARNING
	<p>Pressure Relief Procedure:</p> <p>Follow this procedure before maintaining and/or repairing your Signature Hose Reel and/or any part of system.</p> <ol style="list-style-type: none"> 1) Disconnect the air to the pump. 2) Point dispensing valve away from yourself and others. 3) Open dispensing valve until pressure is relieved.

	! WARNING
	<p>DANGER: Not for use with fluids that have a flash point below 100°F (38°C). Examples: gasoline, alcohol. Sparking could result in an explosion which could result in death.</p>

	CAUTION
	<p>Be aware of possible fluid thermal expansion! A pressure relief valve should be properly installed in any system where this product is used. Should this product fail as a result of thermal expansion and no pressure relief valve was installed, the product warranty will be voided.</p>

	CAUTION
	<p>Fully extend hose before pressurizing or damage may occur to side panels</p>

	! CAUTION
	<p>USE EXTREME CARE WHEN HANDLING THE POWER SPRING!</p> <p>The spring is ALWAYS under great tension and could be propelled from the case with enough force to cause serious bodily injury.</p>

	! WARNING
	<p>Be sure the mounting surface is strong enough to support the reels, the weight of the fluids and the stress caused by hard pulls on the service hoses. See page 3 for dry weights of the hose reel assemblies.</p>

	! WARNING
	<p>The MAXIMUM WORKING PRESSURE of a hose reel is determined by the lowest rated component in the assembly. The hose reel Technical Data chart on page 3 give the maximum working pressure of the reels at the factory with hose. The maximum working pressure of a hose reel is indicated on the hose reel identification plate located near the base of the reel.</p>

TABLE OF CONTENTS

Cover	1	Installation	4 & 5
General safety information	2	Maintenance	6-9
Technical data.....	3	Parts diagram & mounting foot print.....	10
Model numbers.....	3	Parts listing.....	11 & 12
Mounting dimensional data.....	4	Repair Kits.....	12

TECHNICAL DATA

Material inlet:

Low & med. pressure reels..... 1/2" NPT(F)
 High pressure reels 3/8" NPT(F)

Material outlet:

Low & med. pressure reels..... 1/2" NPT(F)
 High pressure reels 3/8" NPT(F)

Wetted parts:

Low pressure.....Brass, Acetal & NBR (Buna)
 Med. pressure..... Steel (plated) & NBR (Buna)
 High pressure.....Steel (phosphating surface treated) & Polyurethane

Hose working pressure ratings:

Air / water hose..... 3/8" – 300 psi
 1/2" – 300 psi
 Med. pressure..... 1/2" – 3000 psi
 High pressure 1/4" – 5000 psi
 3/8" – 4000 psi

Shipping weight:

Std. frame (50 ft hose or less) 61 lbs.
 Lrg. frame (60 ft hose)..... 66 lbs.

MODEL NUMBERS

Type of Service	Model Number	Hose Size	Maximum Working Pressure	Outlet Hose	Inlet Hose	Bare Reel
Low Pressure (LP) Air, Water, Antifreeze	2111-031	30' x 3/8"	300 psi	8136-030	8142-002X	2111-048
	2111-032	40' x 3/8"		8136-040		2111-048
	2111-033	50' x 3/8"		8136-050		2111-048
	2111-034 ⁽¹⁾	60' x 3/8"		8136-060		2111-049
	2111-035	40' x 1/2"		8141-040		2111-048
	2111-036	50' x 1/2"		8141-050		2111-048
	2111-037 ⁽¹⁾	60' x 1/2"		8141-060		2111-049
Medium Pressure (MP) Lubricants	2111-038	30' x 1/2"	3,000 psi	8241-030	8249-002X	2211-027
	2111-039	40' x 1/2"		8241-040		2111-027
	2111-040	50' x 1/2"		8241-050		2111-027
	2111-041 ⁽¹⁾	60' x 1/2"		8241-060		2111-028
High Pressure (HP) Grease	2111-042 ⁽²⁾	40' x 1/4"	5,000 psi	8323-040	8334-002X	2111-029
	2111-043 ⁽²⁾	50' x 1/4"		8323-050		2111-029
	2111-044 ⁽¹⁾⁽²⁾	60' x 1/4"		8323-060		2111-030
	2111-045 ⁽²⁾	40' x 3/8"	4,000 psi	8332-040		2111-029
	2111-046 ⁽²⁾	50' x 3/8"		8332-050		2111-029
	2111-047 ⁽¹⁾⁽²⁾	60' x 3/8"		8332-060		2111-030

(1) 50 feet of hose with 10 feet hanging below the roller outlet.

(2) Reference installation instructions on page 5 item #7, fully extend hose before pressurizing.

PRODUCT DESCRIPTION

The Signature Premium Series hose reel is designed to provide efficient delivery of air, water, oil, or grease through various hose lengths, at an economical price. The roller outlet arm can be adjusted to any one of six positions, which allows floor, table, wall or ceiling mounting (when mounting directly to I-beam, clamping kit no. 2230-017 is available for ease of assembly.)

DIMENSIONS & MOUNTING DIAGRAM

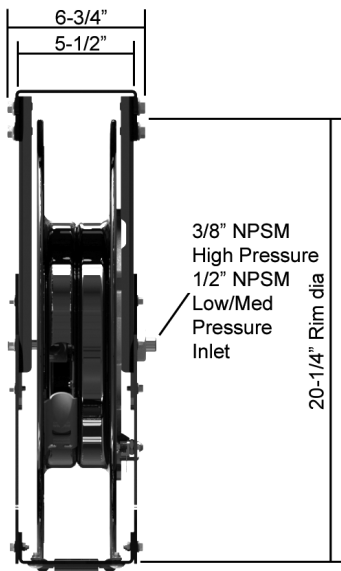

Figure 1

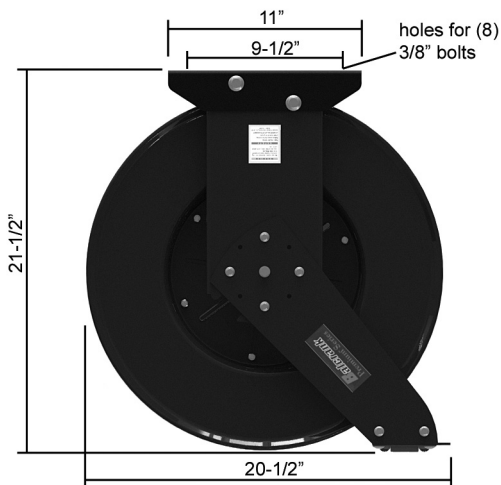

Figure 2

INSTALLATION

The hose reel is shipped ready to use; the power spring tension has been adjusted to maximum tension preset.

1. Select the mounting location. Be sure the mounting structure is secure and will not tip when reel is in operation. Tables should be bolted to floor and wall should be part of building structure. If the ceiling is very high, suspend a suitable support structure for the reels, so the hoses will be long enough to reach service area.
2. Locate the mounting holes for drilling, using measurements on previous page. If mounting directly to H-Beam use mounting kit 2230-017 (no drilling required).
3. To move the hose guide arm and the hose outlet mouth, remove screws I (figure 3), place arm and outlet in correct position and replace screws again.
4. Fasten the base using bolts of a sufficient strength to prevent the reel from "shearing bolts" during operation when hose is pulled.

	WARNING
	<p>Be sure the mounting surface is strong enough to support the reels, the weight of the fluids and the stress caused by hard pulls on the service hoses. See page 3 for dry weights of the hose reel assemblies.</p>

5. Connect supply line to the inlet of hose reel.

NOTE
<p><i>Do not hard pipe inlet/swivel to any existing structure/system. Flexible connection hose must be used to maintain swivel performance.</i></p>

6. Hose reels shipped with hoses come from the factory with the maximum tension preset for ceiling installation. For a typical table/wall installation you would need to adjust to less tension by removing one to two wraps of hose from the spool.

NOTE: Check the power spring tension; the hose must pull out fully and retract fully. Wrap *ONE* more loop onto spool, extend the hose, and latch it. Do this as many times as necessary until the power spring has the desired tension.



CAUTION: Do Not put so many loops onto the reel that the power spring winds tightly before the hose is fully extended. A power spring that has been wound too tight stops rotating before the hose is fully extended. This condition will wear the hose and power spring prematurely. To decrease tension, remove one to two loops of hose from the reel.

7. Install the hose stop and dispensing valve. Position the hose stop so the hose extends far enough for all operators to reach it. **CAUTION:** Always Fully Extend hose before pressurizing or damage may occur to side panels.
8. For smooth operation and longer life, position the reel mounting brackets as per figure 4, with hose outlet always allowing for the tangent in relation to the reel and hose.

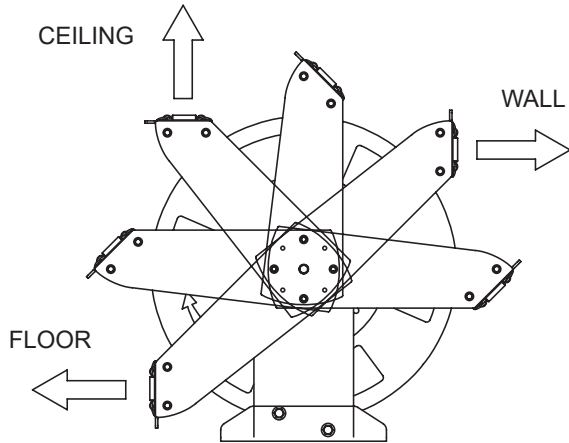

Figure 3

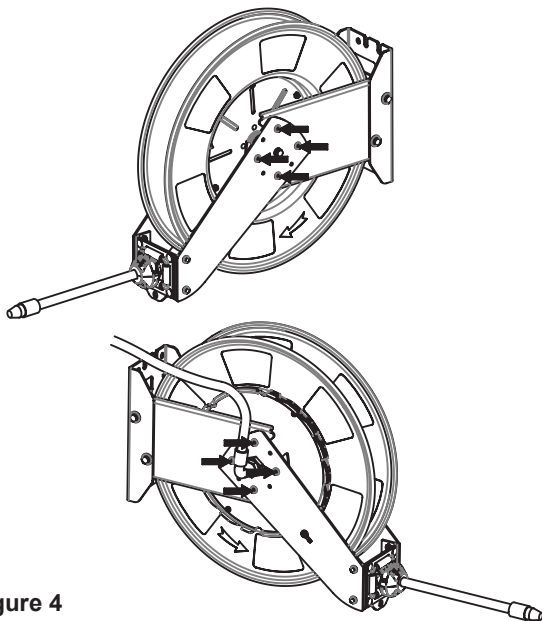

Figure 4

Model 2230-014

Hose reel mounting plate

1. Bolt the hose reel mounting plate onto the mounting channel.
2. Install rear bolts loosely on the mounting plate.
3. Slide the slotted side of the hose reel base into position and hold with the integrated swing clamp which is part of the adapter plate.
4. This leaves both hands free to install and tighten the nuts and bolts which secure the hose reel in final installed position.

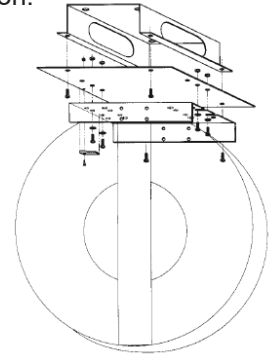

Figure 5

TYPICAL INSTALLATIONS

Ceiling Mounting

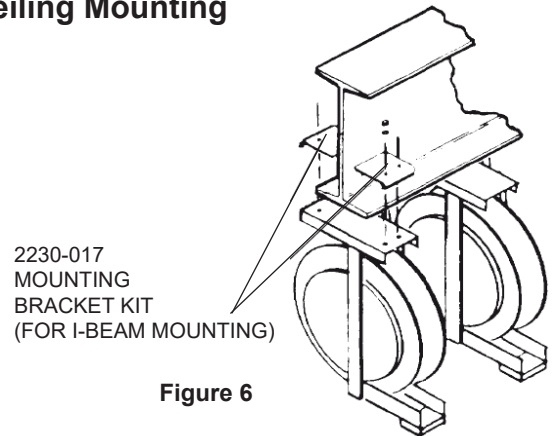

Figure 6

Typical Inlet Line Configuration

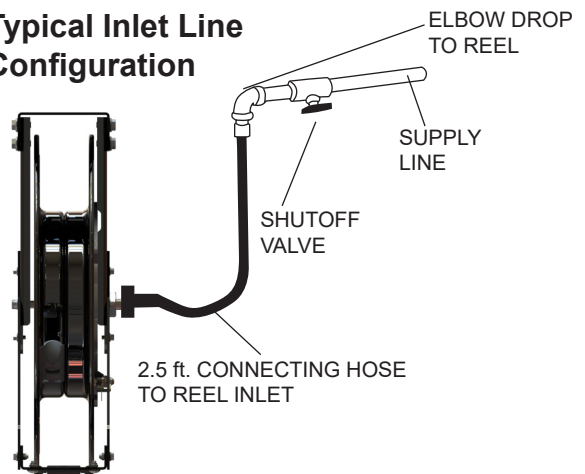

Figure 7

Maintenance

Replacing Service Hose:

1. Be sure the pressure supply has been relieved when replacing the service hose. **Follow the pressure relief procedures below.**
2. Fully extend the service hose. Stop the reel where the hose swivel union is accessible and where the stop pawl is securely latched.
3. Secure spool from accidental rotation by placing a C-Clamp onto the spool. See figure 8 for proper placement of C-Clamp. This will keep the spool from rotating while installing the new service hose.
4. Disconnect and remove service hose.
5. Uncoil the new hose and assemble the bumper stop, attach the new hose to the reel, and remove the C-Clamp carefully.
6. Firmly grasp the hose and pull it to release the stop pawl. Then slowly allow the hose to retract.

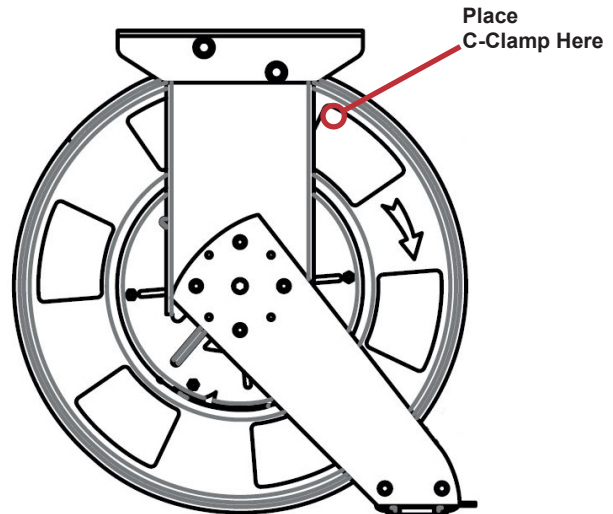

Figure 8



WARNING: Never allow the reel to spin freely. Doing so will cause the hose to spin out of control, which could cause serious injury.

NOTE: Check the power spring tension. The hose must pull out and retract fully. Wrap ONE more loop onto or off the spool, extend the hose, and latch it. Do this as many times as necessary until power spring has the desired tension.



ALWAYS ensure proper operation after spring tension has been set by fully extending the hose & retracting. If the hose reel cannot pull the control handle all the way up to bumper stop setting, more tension is required. Add a wrap to the hose reel. If the hose reel pulls too quickly and jerks the control handle up too fast, less tension is required. Remove a wrap from the hose reel.



NOTE: A spring wound too tightly stops rotating before the hose is fully extended. This condition will place excessive strain on the hose and power spring that could damage and/or shorten the life of the reel.



WARNING

Pressure Relief Procedure:

Follow this procedure before maintaining and/or repairing your Premium Hose Reel and/or any part of system.

- 1) Disconnect the air to the pump.
- 2) Point dispensing valve away from yourself and others.
- 3) Open dispensing valve until pressure is relieved.

Replacing Seals in Swivel:

1. Be sure the pressure supply has been relieved. **Follow the pressure relief procedures on page this page.**
2. Retract the hose fully and allow the spool to latch. Remove the hose stop & dispensing valve.
3. Remove tension from reel. Wearing heavy leather gloves, firmly grasp the outside edge of the spool with both hands and unlatch the spool. Let the spool rotate slowly through your hands until the spool stops. When the spool stops the spring tension will be released.

4. Unscrew the hose from the swivel.

 Note
<p>Refer to parts diagram on page 10 for the following steps.</p>

5. Remove the arm (43). For this, it is necessary to unscrew the bolts (14 & 18), the bolt (46), and remove the washers (44 & 45).
6. It will be necessary to loosen or remove the upright (3) for the next step.
7. Remove the snap ring (42) and pull the swivel off of the shaft.
8. Remove the worn o-rings (low/medium pressure reels) or polyurethane seals (high pressure reel). Clean the swivel and shaft. Inspect for wear and damage. Install new o-rings/seals in the swivel (see figure 9). Grease the o-rings/seals.
9. Slide the swivel back into place being careful not to damage the new o-rings/seals. Secure swivel with snap ring & reassemble.

Swivel Seal Assembly

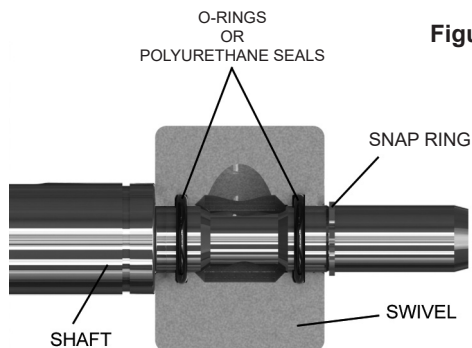



Figure 9

MAINTENANCE

Replacing Power Spring Assembly:

1. Be sure the system pressure has been relieved. **Follow the pressure relief procedure on page 6.**
2. Disconnect inlet hose. Remove the reel to work bench and clamp reel base securely.
3. Retract the hose totally. Then, be sure to let the hose reel latch.
4. Remove the hose stop and dispensing valve.
5. Wearing heavy leather gloves, firmly grasp the outside edge of the spool with both hands

and unlatch the spool. Let the spool rotate slowly through your hands until the spool stops. When the spool stops the spring tension will be released. The spool can now be removed.

 WARNING: <i>Wear Heavy Leather Gloves</i> when replacing service hose and/or replacing power spring to protect your hands from injury.

 Note
<p>Refer to figure 10 on page 8 for the following steps.</p>

6. Remove the arm (17) with the latch mount on it. For this, it is necessary to unscrew the bolts (14 & 18), the nut (15), and the washer (16).
7. Unscrew the bolts (26) in order to open the spring canister.

 CAUTION	
USE EXTREME CARE WHEN HANDLING THE POWER SPRING!	
<p>The spring is ALWAYS under great tension and could be propelled from the case with enough force to cause serious bodily injury. To reduce the risk of serious bodily injury, use extreme caution when removing the top cover. Be sure the spring case is lying flat, and then carefully lift up the cover to expose the power spring.</p>	

8. Removing the power spring; use locking type pliers to compress and hold several rows of the power spring together, then lift out the power spring slowly and place two hose clamp style clamps around the power spring and keeper before disposing of power spring.

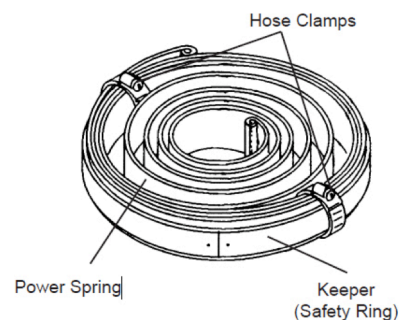

9. Apply a light coat of grease inside the spring case and cover.

10. Install the new power spring, making sure that it is laid into the spring case Clockwise and that the outside end loop is around the flange sited inside the spool.
11. Cover the spring, making sure the lid (27) is well fitted to the bushing (34). And assemble the arm (17). Pay special attention when mounting the inner end loop of the spring to ensure it is aligned with the flange on the spring hub (35).
12. Once the hose reel is reassembled, it is necessary to adjust the spring tension. For this, wearing heavy leather gloves, firmly grasp the

outside edge of the spool with both hands and manually rotate the spool in the hose extraction direction two to three turns (without extending the hose) and allow the spool to latch.

13. After the pre tension turns (with the spool latched), pass the hose through the hose outlet and assemble the hose stop to the required length.
14. Pull the hose hard enough to release the latch, and slowly allow the hose to retract.

! **NOTE:** A spring wound too tightly stops rotating before the hose is fully extended. This condition will place excessive strain on the hose and power spring that could damage and/or shorten the life of the reel.

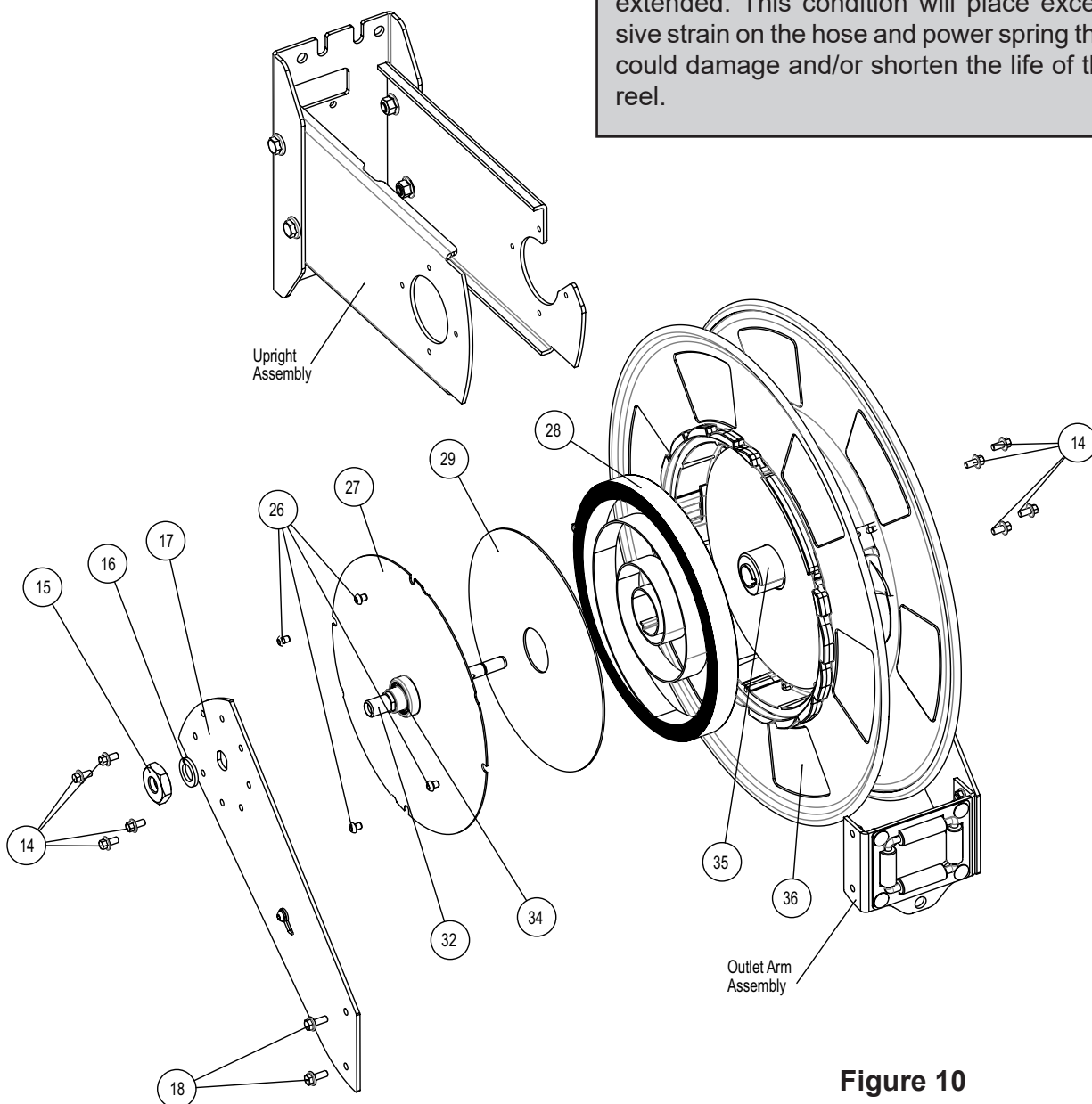





Figure 10

MAINTENANCE

Stop Pawl Replacement:

	 WARNING
Pressure Relief Procedure:	
<p>Follow this procedure before maintaining and/or repairing your Signature Hose Reel and/or any part of system.</p>	
<ol style="list-style-type: none"> 1) Disconnect the air to the pump. 2) Point dispensing valve away from yourself and others. 3) Open dispensing valve until pressure is relieved. 	

1. Make sure the hose is totally rewound. The spool must be held by the hose stop.
2. Remove the bolt (19) that fixes the latch (21).
3. Remove the snap ring (25) and replace the stop pawl (23) and/or the pawl spring (24).
4. Re-assemble the pieces in reverse order.

	<p>CAUTION: Never alter or modify any parts of this reel. Doing so may cause damage to reel and/or personal injury and will void warranty. Always use genuine Balcrank replacement parts.</p>
---	--

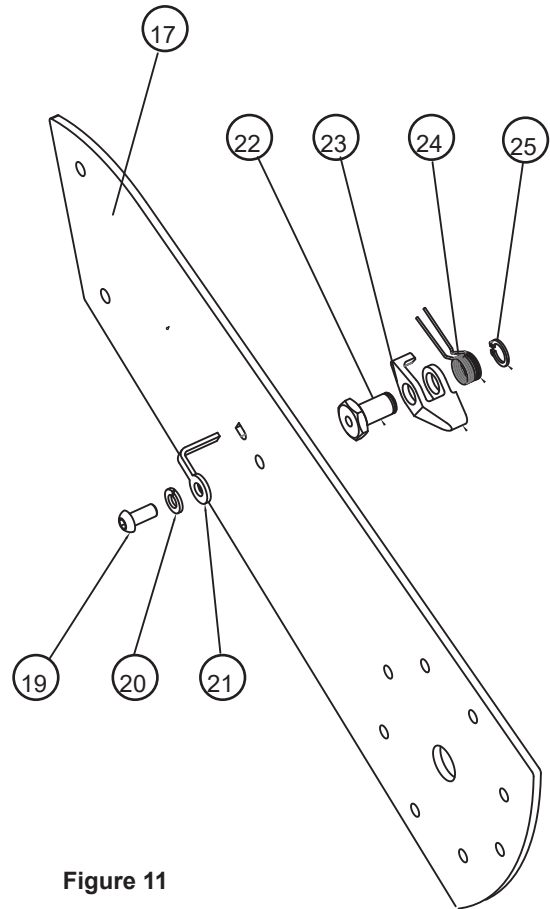
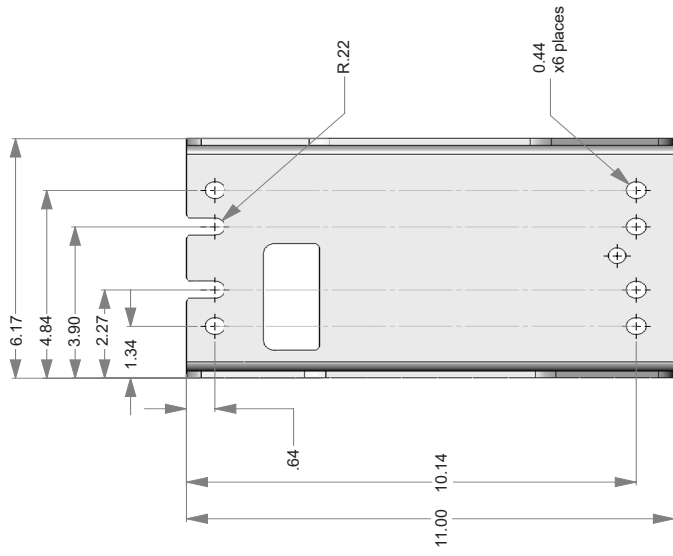

Figure 11

TROUBLESHOOTING GUIDE

Symptom	Possible Causes	Solution
Hose does not rewind	Spring is not tensioned enough	Increase spring tension
Leaking hose reel	Hose has a hole or is damaged	Replace the hose
Leaking swivel	Damaged O-rings	Replace the O-rings
Hose does not extend out as much as required	Spring is over tensioned	Decrease spring tension
Hose reel does not latch	Damaged stop pawl	Replace the stop pawl
	Stop pawl not fitted	Assemble the stop pawl properly
	Damaged stop pawl spring	Replace the stop pawl spring

PARTS DIAGRAM SIGNATURE PREMIUM REELS



Signature Premium Reel
Mounting Footprint

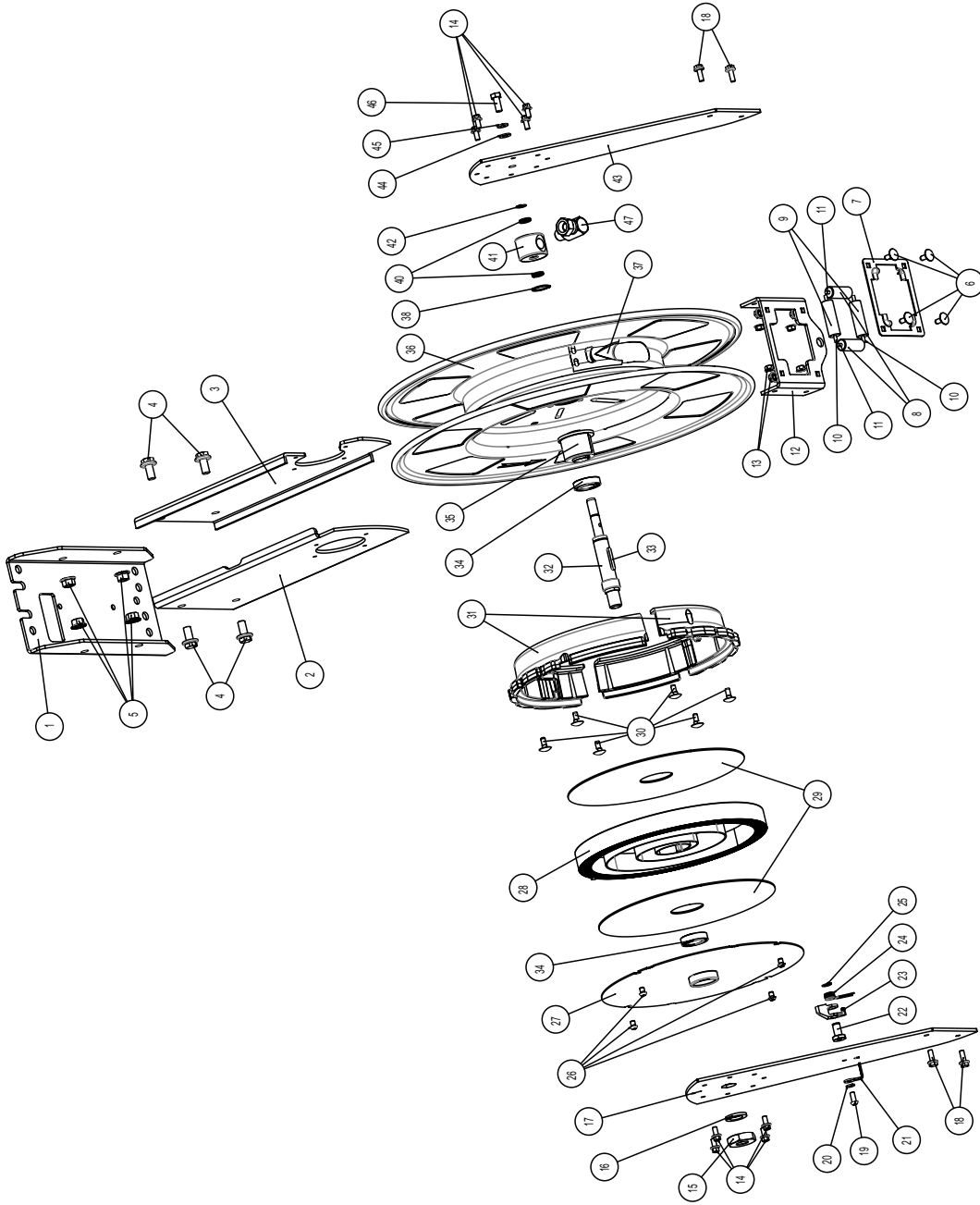

PARTS LISTING

PREMIUM REELS

ITEM	DESCRIPTION	QTY	Bare Reel 2111-048 50' LP	Bare Reel 2111-049 50+10' LP	Bare Reel 2111-027 50' MP	Bare Reel 2111-028 50'+10' MP	Bare Reel 2111-029 50' HP	Bare Reel 2111-030 50+10' HP
1	Base	1	X	X	X	X	X	X
2	Lower arm latch	1	X	X	X	X	X	X
3	Lower arm swivel	1	X	X	X	X	X	X
4	Base bolt	4	X	X	X	X	X	X
5	Base nut	4	X	X	X	X	X	X
6	Roller support bolt	4	X	X	X	X	X	X
7	Roller support	1	X	X	X	X	X	X
8	Short roller	2	X	X	X	X	X	X
9	Long roller	2	X	X	X	X	X	X
10	Long roller axle	2	X	X	X	X	X	X
11	Short roller axle	2	X	X	X	X	X	X
12	Hose outlet	1	X	X	X	X	X	X
13	Hose outlet nut	8	X	X	X	X	X	X
14	Upper arms bolt	4	X	X	X	X	X	X
15	Shaft nut 3/8"	1					X	X
	Shaft nut 1/2"		X	X	X	X		
16	Lock washer 3/8" shaft	1					X	X
	Lock washer 1/2" shaft		X	X	X	X		
17	Upper arm latch 3/8"	1					X	X
	Upper arm latch 1/2"		X	X	X	X		
18	Hose outlet bolt	4	X	X	X	X	X	X
19	Stop pawl bolt	1	X	X	X	X	X	X
20	Stop pawl lock washer	1	X	X	X	X	X	X
21	Stop pawl spring stop	1	X	X	X	X	X	X
22	Stop pawl axle	1	X	X	X	X	X	X
23	Stop pawl	1	X	X	X	X	X	X
24	Stop pawl spring	1	X	X	X	X	X	X
25	Stop pawl spring washer	1	X	X	X	X	X	X
26	Power spring cover bolt	4	X	X	X	X	X	X
27	Power spring cover	1	X	X	X	X	X	X
28	Power spring for 50' + 10' hose	1	X	X	X	X	X	X
29	Silencer	2	X	X	X	X	X	X
30	Ratchet anchor bolt	6	X	X	X	X	X	X
31	Ratchet	2	X	X	X	X	X	X
32	HP shaft 3/8" NPT (M)	1					X	X
	MP shaft 1/2" NPT (M)				X	X		
	LP brass shaft 1/2" NPT (M)		X	X				
33	Key	1	X	X	X	X	X	X
34	Bushing	2	X	X	X	X	X	X
35	Spring hub	1	X	X	X	X	X	X
36	Spool	1	X	X	X	X	X	X
37	Hose support	1	X	X	X	X	X	X
38	Shaft snap ring	1	X	X	X	X	X	X

ITEM	DESCRIPTION	QTY	Bare Reel 2111-048 50' LP	Bare Reel 2111-049 50+10' LP	Bare Reel 2111-027 50' MP	Bare Reel 2111-028 50'+10' MP	Bare Reel 2111-029 50' HP	Bare Reel 2111-030 50+10' HP
40	Polyurethane seal for 3/8" shaft	2					X	X
	O-ring NBR for 1/2" shaft		X	X	X	X		
41	LP swivel	1	X	X				
	MP swivel				X	X		
	HP swivel						X	X
42	Swivel snap ring for 3/8" shaft	1					X	X
	Swivel snap ring for 1/2" shaft		X	X	X	X		
43	Upper arm swivel	1	X	X	X	X	X	X
44	Upper arm swivel washer for 3/8"	1					X	X
	Upper arm swivel washer for 1/2"		X	X	X	X		
45	Upper arm swivel lock washer for 3/8"	1					X	X
	Upper arm swivel lock washer for 1/2"		X	X	X	X		
46	Upper arm swivel bolt for 3/8"	1					X	X
	Upper arm swivel bolt for 1/2"		X	X	X	X		
47	Elbow, 1/2" NPSM	1	X	X	X	X		
	Elbow, 3/8" NPSM						X	X

REPAIR KITS

Description	Part Number	Included Items
Kit, Stop pawl	833147	19, 20, 21, 22, 23, 24, 25
Kit, Roller outlet	833031	6, 7, 8, 9, 10, 11,13
Kit, Swivel Seals replacement (LP/MP)	833029	40, 42
Kit, Swivel Seals replacement (HP)	833030	40, 42
Kit, LP Swivel assembly	833703	40, 41, 47
Kit, MP Swivel assembly	833701	40, 41, 47
Kit, HP Swivel assembly	833702	40, 41, 47

REPLACEMENT POWER SPRINGS

Description	Part Number	Included Items
Power spring (up to 50' + 10' of hose)	833146	28

**For Warranty Information Visit:
www.balcrank.com**

Balcrank™ Corporation
Weaverville, NC 28787
800-747-5300
800-763-0840 Fax
www.balcrank.com

SERVICE BULLETIN SB2027
REV. H 4/2018

Revision Log:

- Rev. A - Release
- Rev. B - Removed item 39 (not used) and changed description of item 40 for grease reel models
- Rev. C - Changed figure 9 & exploded view on page 10 to reflect current parts. Removed item 39 from parts list
- Rev. D - Updated exploded views on pages 8 & 10. Updates tables on pages 11 & 12. Items updated/added - 29 & 47
- Rev. E - Added new LP reels to product line.
- Rev. F - Revised Installation step 6 copy
- Rev. G - Added repair kits to page 12 and edited descriptions
- Rev. H - Removed power spring for up to 50' hose on pages 11 & 12