

Balcrank[®]

Signature EV Reels *Extended Volume*

Models: 2310-XXX

2400-010

2400-011

See page 3 for Hose Reel Model
Numbers and Technical Data



Thoroughly read and understand this manual before installing, operating or servicing this equipment.

**OPERATION, INSTALLATION,
MAINTENANCE AND REPAIR GUIDE**

General Safety

Thoroughly read and understand this manual before installing, operating or servicing this equipment.

	<p>! IMPORTANT</p>
<p>Read these safety warnings instructions in this manual completely, before installation and start-up of the reel. It is the responsibility of the purchaser to retain this manual for reference. Failure to comply with the recommendations stated in this manual will damage the reel and void factory warranty.</p>	

	<p>! IMPORTANT</p>
<p>Because this Hose Reel can be incorporated into a pressurized systems, the following safety precautions should be observed.</p> <p>Check equipment regularly and repair or replace worn and damaged parts.</p> <p>Never alter or modify any parts of this hose reel, doing so may cause damage to hose reel and/or personal injury.</p> <p>Under no circumstances should the dispensing valve be aimed at any person at any time. Personal injury may result.</p> <p>Release pressures built up in the system before any service or repair is begun. See the pressure relief procedure below.</p> <p>Always read and follow the fluid manufacturer's recommendations regarding the use of protective eyewear, clothing and respirators.</p>	

	<p>! WARNING</p>
<p>Pressure Relief Procedure:</p> <p>Follow this procedure before maintaining and/or repairing your Signature Hose Reel and/or any part of system.</p> <ol style="list-style-type: none"> 1) Disconnect the air to the pump. 2) Point dispensing valve away from yourself and others. 3) Open dispensing valve until pressure is relieved. 	

	<p>! WARNING</p>
<p>DANGER: Not for use with fluids that have a flash point below 100°F (38°C). Examples: gasoline, alcohol. Sparking could result in an explosion which could result in death.</p>	

	<p>CAUTION</p>
<p>Be aware of possible fluid thermal expansion! A pressure relief valve should be properly installed in any system where this product is used. Should this product fail as a result of thermal expansion and no pressure relief valve was installed, the product warranty will be voided.</p>	

	<p>CAUTION</p>
<p>Fully extend hose before pressurizing or damage may occur to side panels</p>	

	<p>! WARNING</p>
<p>Be sure the mounting surface is strong enough to support the reels, the weight of the fluids and the stress caused by hard pulls on the service hoses. See page 3 for dry weights of the hose reel assemblies.</p>	

	<p>! WARNING</p>
<p>The <i>MAXIMUM WORKING PRESSURE</i> of a hose reel is determined by the lowest rated component in the assembly. The hose reel Technical Data chart on page 3 give the maximum working pressure of the reels at the factory with hose. The maximum working pressure of a hose reel is indicated on the hose reel identification plate located near the base of the reel.</p>	

TABLE OF CONTENTS

Cover	1	Installation	4 & 5
General safety information	2	Maintenance	6 & 7
Technical data.....	3	Troubleshooting.....	8
Model numbers.....	3	Parts listing.....	8
Dimensional data.....	4	Parts diagram	9

TECHNICAL DATA

Fluid inlet/outlet port:

Low /Med. pressure reels	3/4" NPT(F)
Low /Med. pressure DEF reels	3/4" BSPP(F)
High pressure reels.....	3/8" NPT(F)

Wetted parts (Air/Water, Lube & Diesel):

Steel (electroless nickel coated) & NBR (Buna)

Wetted parts (Diesel Exhaust Fluid):

Stainless Steel, Polypropylene, & Viton

Wetted parts (Grease):

Nickel Plated Steel, Hardened steel and Polyurethane

Hose working pressure ratings:

Low pressure (Air / water)	1/2" – 300 psi
	3/4" – 300 psi
Med. pressure.....	1/2" – 2,750 psi
	3/4" – 1,950 psi
High pressure	3/8" – 5,000 psi
Diesel Fuel.....	3/4" – 50 psi
Diesel Exhaust Fluid.....	3/4" – 150 psi

Shipping weight:

50 ft hose (3/4" Oil).....	95 lbs.
65 ft hose (1/2" Oil).....	92 lbs.
65 ft hose (3/8" Grease).....	91 lbs.
Bare Reel.....	73 lbs.

MODEL NUMBERS

Type of service	Model number	Hose size	Maximum working pressure	Outlet hose	Inlet hose	Bare Reel Model
Low pressure air, water	2310-027	65' x 1/2"	300 psi	8141-065	8161-002X	2310-033
	2310-028	50' x 3/4"	300 psi	8161-050	8161-002X	2310-033
Med. pressure oil, ATF, anti-freeze	2310-029	65' x 1/2"	2,750 psi	8250-065	8264-002X	2310-033
	2310-031	50' x 3/4"	1,950 psi	8264-050	8264-002X	2310-033
Grease	2310-046	65' x 3/8"	5,000 psi	8332-065	8334-002X	N/A
Diesel	2310-032	50' x 3/4"	50 psi	8466-050	8466-002X	2310-033
DEF (Diesel Exhaust Fluid)	2400-011	50' x 3/4"	50 psi	8569-050	8562-003	2400-010
Bare Reel (DEF)	2400-010 ⁽¹⁾	N/A	50 psi	N/A	N/A	N/A

(1) Up to 50 feet of 3/4" hose.

PRODUCT DESCRIPTION

The Signature EV Series hose reel is designed to provide efficient delivery of air, water, oil, or diesel through various hose lengths. The roller outlet arm can be adjusted to any one of seven positions, which allows floor, table, wall or ceiling mounting.

DIMENSIONS

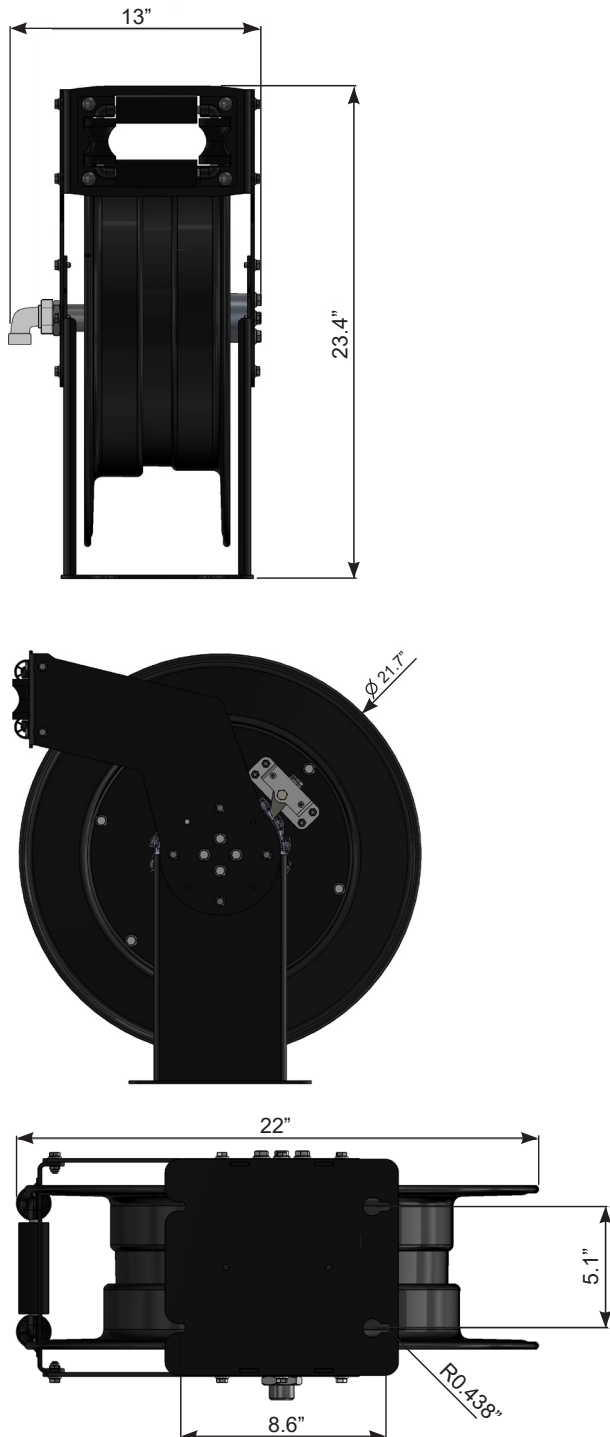

Figure 1

INSTALLATION

The hose reel is shipped ready to use; the power spring tension has been adjusted for table/wall mounting.

1. Select the mounting location. Be sure the mounting structure is secure and will not tip when reel is in operation. Tables should be bolted to floor and wall should be part of building structure. If the ceiling is very high, suspend a suitable support structure for the reels, so the hoses will be long enough to reach the service area.
2. Locate the mounting holes for drilling.
3. To move the hose guide arm and the hose outlet mouth, remove screws (1) (figure 2), place arm and outlet in correct position (figure 3) and replace screws.



CAUTION

Do not attempt to change the guide arms position without having the reel placed on a horizontal support surface (floor, workbench, etc.).

4. Fasten the base using bolts of a sufficient strength to prevent the reel from "shearing bolts" during operation when hose is pulled.
5. Connect supply line to the inlet hose of reel.



WARNING

Be sure the mounting surface is strong enough to support the reels, the weight of the fluids and the stress caused by hard pulls on the service hoses. See page 3 for dry weights of the hose reel assemblies.



NOTE

Do not hard pipe inlet/swivel to any existing structure/system. Flexible connection hose must be used to maintain swivel performance.

6. Hose reels shipped with hoses come from the factory with the tension preset for a typical table/wall installation. For a ceiling installation you will need to adjust for more or less tension, by removing or adding one to two wraps of hose from spool.

NOTE: Check the power spring tension; the hose must pull out fully and retract fully. Wrap *ONE* more loop onto spool, extend the hose, and latch it. Do this as many times as necessary until the power spring has the desired tension.

CAUTION: Do Not put so many loops onto the reel that the power spring winds tightly before the hose is fully extended. A power spring that has been wound too tight stops rotating before the hose is fully extended. This condition will wear the hose and power spring prematurely. To decrease tension, remove one to two loops of hose from the reel.

7. Install the hose stop and dispensing valve. Position the hose stop so the hose extends far enough for all operators to reach it. **CAUTION:** Always Fully Extend hose before pressurizing or damage may occur to side panels.
8. For smooth operation and longer life, position the reel mounting brackets, with hose outlet always allowing for the proper tangent in relation to the reel and hose.

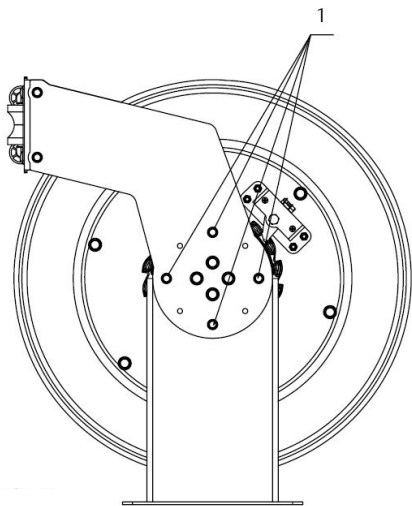

Figure 2

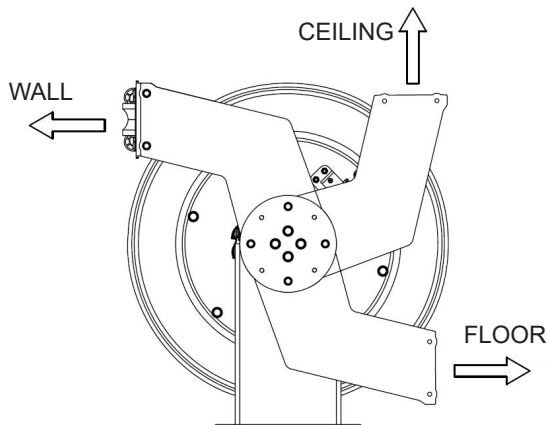

Figure 3

TYPICAL INSTALLATIONS

Ceiling Mounting

Model 2230-014

Hose reel mounting plate

1. Bolt the hose reel mounting plate onto the mounting channel.
2. Install rear bolts loosely on the mounting plate.
3. Slide the slotted side of the hose reel base into position and hold with the integrated swing clamp which is part of the adapter plate.
4. This leaves both hands free to install and tighten the nuts and bolts which secure the hose reel in final installed position.

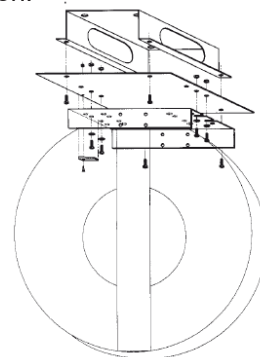

Figure 4

Typical Inlet Line Configuration

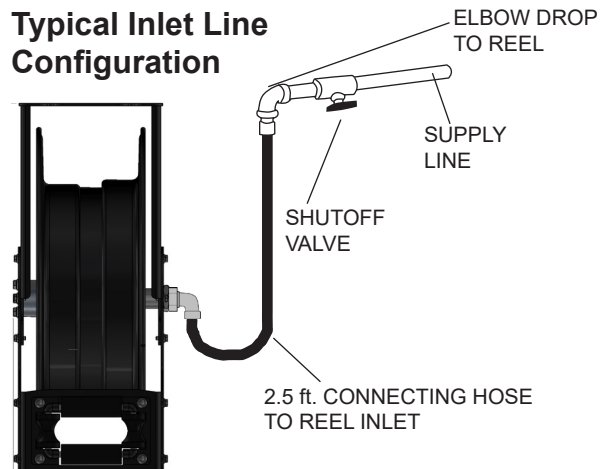

Figure 5

Maintenance

Replacing Service Hose:

1. Be sure the pressure supply has been relieved when replacing the service hose. **Follow the pressure relief procedures below.**
2. Fully extend the service hose. Stop the reel where the hose swivel union is accessible and where the stop pawl is securely latched.
3. Secure spool from accidental rotation by placing a C-Clamp onto the spool. See figure 6 for proper placement of C-Clamp. This will keep the spool from rotating while removing and installing the new service hose.
4. Disconnect and remove service hose U- bolt by loosening nuts (1) and disconnect hose from 90° adapter (2) (figure 7).
5. Uncoil the new hose and assemble the hose stop, attach the new hose to the reel, reinstall U-bolt and carefully remove the C-Clamp.
6. Firmly grasp the hose and pull it to release the stop pawl, then slowly allow the hose to retract.

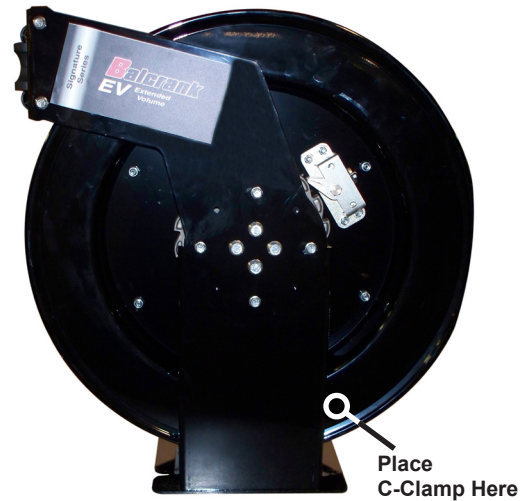

Figure 6

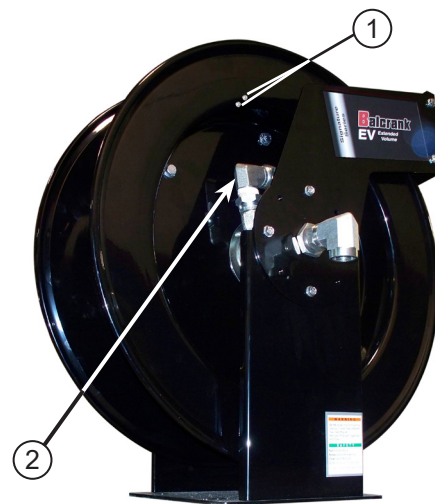

Figure 7



WARNING: Never allow the reel to spin freely. Doing so will cause the hose to spin out of control, which could cause serious injury.

NOTE: Check the power spring tension. The hose must pull out and retract fully. Wrap ONE more loop onto or off the spool, extend the hose, and latch it. Do this as many times as necessary until power spring has the desired tension.



WARNING

Pressure Relief Procedure:

Follow this procedure before maintaining and/or repairing your hose reel and/or any part of system.

- 1) Disconnect the air to the pump.
- 2) Point dispensing valve away from yourself and others.
- 3) Open dispensing valve until pressure is relieved.



ALWAYS ensure proper operation after spring tension has been set by fully extending the hose & retracting. If the hose reel cannot pull the control handle all the way up to hose stop setting, more tension is required. Add a wrap to the hose reel. If the hose reel pulls too quickly and jerks the control handle up too fast, less tension is required. Remove a wrap from the hose reel.



NOTE: A spring wound too tightly stops rotating before the hose is fully extended. This condition will place excessive strain on the hose and power spring that could damage and/or shorten the life of the reel.

Replacing Swivel / Swivel Seals:

1. Be sure the pressure supply has been relieved. **Follow the pressure relief procedures on page 6.**
2. Retract the hose fully and allow the spool to latch. Remove the hose stop & dispensing valve.
3. Disconnect inlet hose (1) (figure 8).
4. Remove tension from reel. Wearing heavy leather gloves, firmly grasp the outside edge of the spool with both hands and unlatch the spool. Let the spool rotate slowly through your hands until the spool stops. When the spool stops the spring tension will be released.

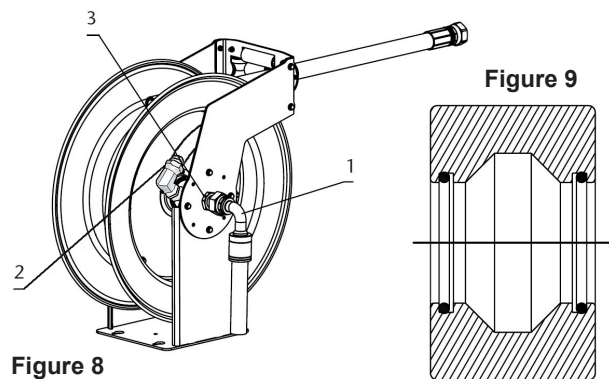

Figure 8

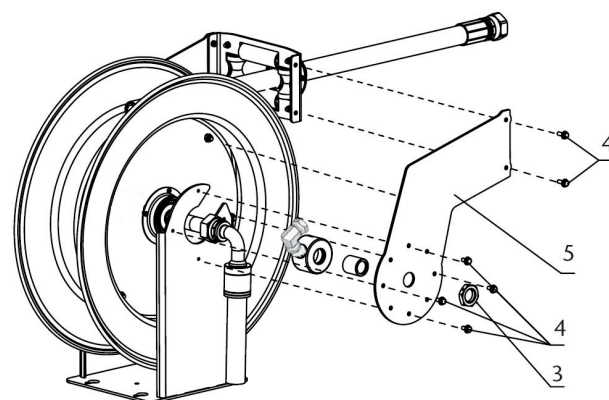

Figure 10

5. Disconnect main hose at 90° adapter joint (2) (figure 8)
6. Loosen set screw in nut (3) (figure 8) and remove nut.
7. Remove screws (4) and arm (5) (figure 10)
8. Remove the swivel and replace or replace seals. Clean the swivel and shaft. Inspect for wear and damage. If only replacing the seals, install the new o-rings in the swivel and ensure they are properly installed (figure 9).
9. Grease the interior of the swivel and carefully slide it on to the shaft until it touches the bearing on the spool. **(Ensure the o-rings/seals do not touch the threads on the reel shaft).**
10. Reassemble reel following the steps above in reverse order.

11. Once the hose reel is reassembled, it is necessary to adjust the spring tension. For this, wearing heavy leather gloves, firmly grasp the outside edge of the spool with both hands and manually rotate the spool in the hose extraction direction two to three turns (without extending the hose) and allow the spool to latch.
12. After the pre tension turns (with the spool latched), pass the hose through the hose outlet and assemble the hose stop to the required length.
13. Pull the hose hard enough to release the latch, and slowly allow the hose to retract.

Maintenance

Stop Pawl Replacement:

1. With the hose fully wound on the spool and the hose stop touching the rollers, remove the screws (1) (figure 11). **(Use the access holes in the bracket).**
2. Unscrew the stop pawl shaft (2) and remove the stop pawl assembly.
3. Clean the parts or replace them if necessary, and assemble them again in reverse order.
4. Extend and retract the hose to ensure the stop pawl assembly works properly.

CAUTION: Never alter or modify any parts of this reel. Doing so may cause damage to reel and/or personal injury. Always use genuine Balcrank replacement parts.

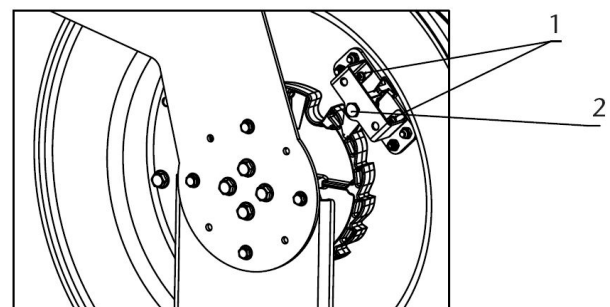
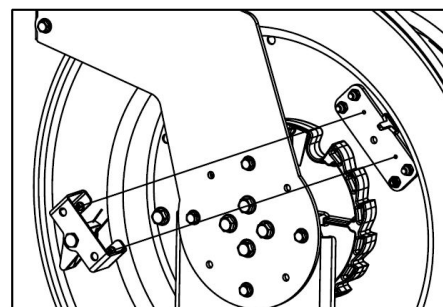

Figure 11



TROUBLESHOOTING GUIDE

Symptom	Possible Causes	Solution
Hose does not rewind	Spring is not tensioned enough	Increase spring tension
Leaking hose reel	Hose has a hole or is damaged	Replace the hose
Leaking swivel	Damaged swivel seals	Replace the seals
Hose does not extend out as much as required	Spring is over tensioned	Decrease spring tension
Hose reel does not latch	Damaged stop pawl	Replace the stop pawl
	Stop pawl not fitted	Assemble the stop pawl properly
	Damaged stop pawl spring	Replace the stop pawl spring

PARTS LISTING SIGNATURE EV REELS

Description	Item Number(s)	Part Number
Roller outlet assembly	7 2, 3, 4, 6 (x2) 1, 5, 8 (x4)	833265
Stop pawl assembly	9, 10, 12, 13, 14, 15 11 (x2)	833262
Swivel seals only	17 (x2)	833266
Swivel with seals	16 & 17 (x2)	833267
Union, Swivel 90, 3/4"NPSM X 3/4"NPT(F)	18	3270-058
Union, Swivel 45, 3/4"NPSM X 3/4"NPT(M)	19	3270-062
Union, Swivel 90, 3/4"NPSM X 3/4"NPT(M)	20	3270-057

PARTS LISTING SIGNATURE EV DEF REELS

Description	Item Number(s)	Part Number
Roller outlet assembly	7 2, 3, 4, 6 (x2) 1, 5, 8 (x4)	833265
Stop pawl assembly	9, 10, 12, 13, 14, 15 11 (x2)	833262
Swivel seals only (DEF Reels)	17 (x2)	833316
Swivel with seals (DEF Reels)	16 & 17 (x2)	833315
Swivel 1"BSPP (F) X 3/4" BSPP (M) (DEF Reels)	18	832947
Elbow, 1" BSPP(M) X 3/4" BSPP(F), 90DEG (DEF Reels)	19	832964
Elbow, 90, SS, 3/4" BSPP(F) Swivel B/E (DEF Reels)	20	833406

PARTS DIAGRAM SIGNATURE EV REELS

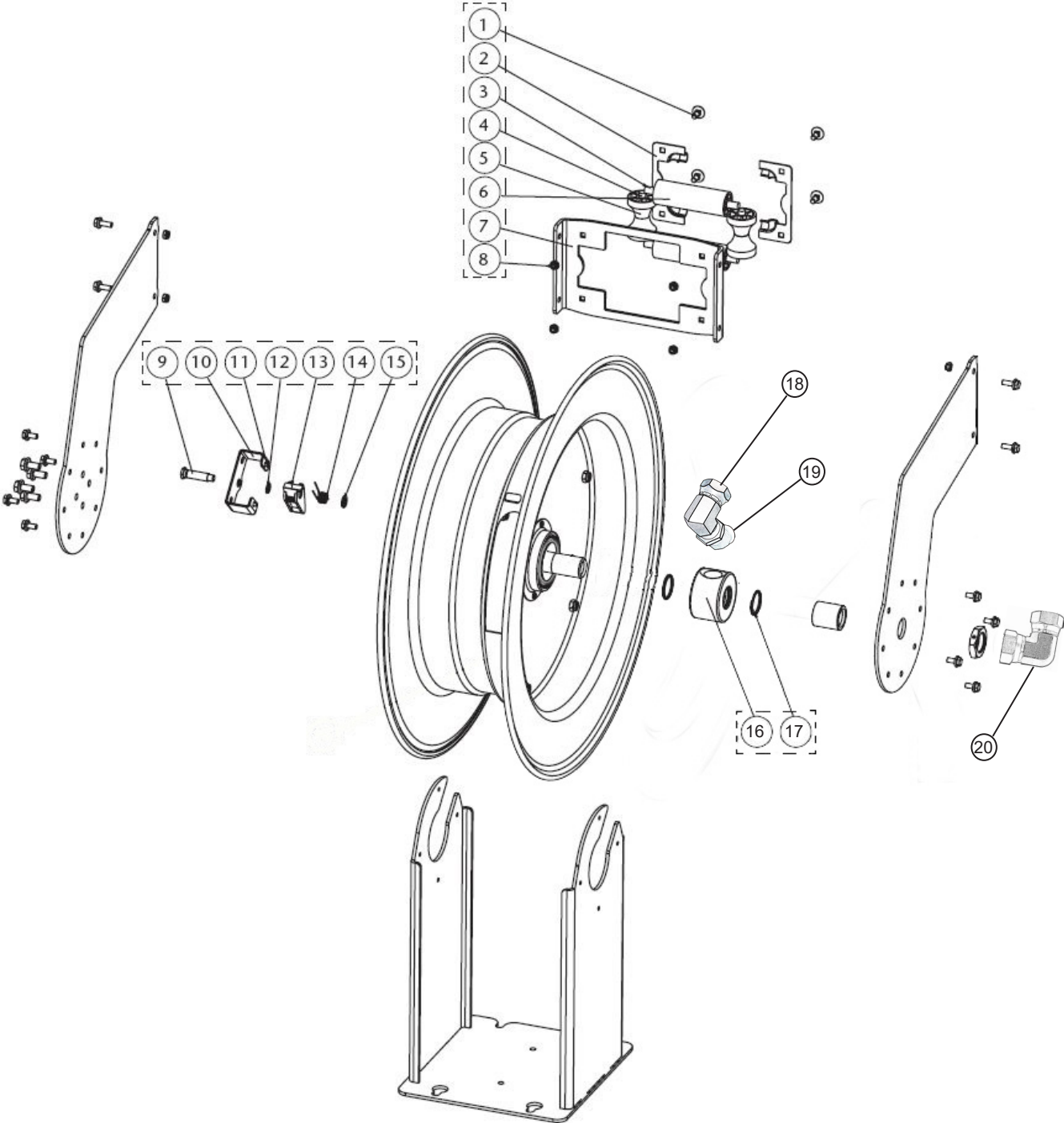

**For Warranty Information Visit:
www.balcrank.com**

Balcrank™ Corporation
Weaverville, NC 28787
800-747-5300
800-763-0840 Fax
www.balcrank.com

SERVICE BULLETIN SB2028
Revision C 9/14

Revision Log:

Rev. A - Release
Rev. B - Added diesel exhaust fluid models
Rev. C - Added part numbers for inlet & outlet
swivels