

Features

- Extract used oil and other fluids from any vehicle - safer, cleaner
- No more stripped drain plugs
- Great for cars, boats, motorcycles, and small engines
- Easily remove overfills
- Vacuum-charged unit is completely portable and easy to use
- Includes five suction probes (metal and flexible)
- Suction probes equipped with quick disconnect couplers
- Adapters for BMW and Volkswagen included
- Self-evacuating feature makes emptying clean and easy
- Available version with clear bowl
Capacity: 2 gal (7.5 l)



TECHNICAL DATA		
	4140-056	4140-057
Tank capacity	18.5 gal (64.35 l)	18.5 gal (64.35 l)
Max. draining capacity	70%	80%
Air pressure for vacuum	100 psi (7 bar)	100 psi (7 bar)
Depressurization time	2' 15"	2' 15"
Suction hose	6 1/2" (2m)	6 1/2" (2m)
Draining hose	5' (1.5 m)	5' (1.5 m)
Service Bulletin	SB 4081	SB 4082

Warning! Not to be used with flammable fluids.

EXTRACTOR WANDS			
Part Number	Material	Wand Kit	Wand Kit Includes
833453	All	Wand Kit	Wand Kit Includes
833462	Flex	.27 X .19 X 39.37 (7 X 5 X 1000)	✓
833465	Flex	.23 X .15 X 27.55 (6 X 4 X 700)	✓
833466	Flex	.31 X .23 X 27.55 (8 X 6 X 700)	✓
833463	Rigid Copper	.19 X .15 X 27.55 (5 X 4 X 700)	✓
833464	Rigid Copper	.23 X .19 X 27.55 (6 X 5 X 700)	✓
833460	Adapter	Volkswagen, Audi Group	✓
833461	Adapter	Peugeot Group	✓



MODELS AVAILABLE	DESCRIPTION
4140-056	Oil Evacuator
4140-057	Oil Evacuator with Clear Dome and Mercedes adapter
833472	Vacuum pump kit

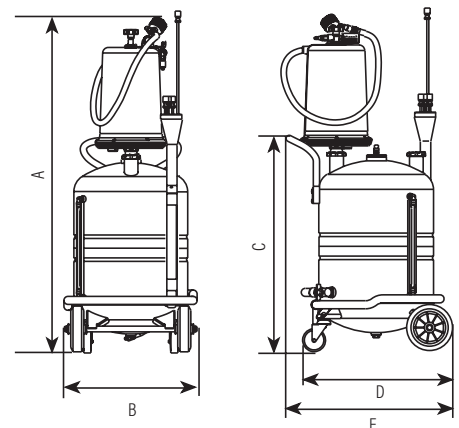

Dimensions inches (MM)				
A	B	C	D	E
46.06" (1,170)	18.5" (470)	29.5" (750)	18.70" (475)	22.84" (580)