

Balcrank[®]

HIGH PRESSURE HAND PUMP Model: 1300-009



CAUTION

Do not lay pump on ground or floor while changing pails as this will result in dirt or foreign material getting into the pump tube. Place pump on clean paper or shop rag. KEEP GREASE CLEAN!



CAUTION

Pump has the capability of developing 5,000 psi fluid pressure. Always reduce fluid supply pressure to zero before servicing.

ASSEMBLY:

1. Remove clamp nut at base of pump head.
2. Insert pump through hole in center of product cover, replace clamp nut on underside of product cover and tighten securely.
3. Attach lever handle to top of pump rod; replace bolt, lock washer and nut. Tighten securely.
4. Attach outlet assembly to end of hose. Tighten assembly securely with a wrench.
5. Screw other end of hose into outlet of the pump head and tighten.

OPERATION:

Pull pump handle up slowly its entire length of travel, work handle up and down a few strokes. Operate pump handle until grease is forced through entire hose assembly.

TROUBLE SHOOTING:

If the pump does not deliver lubricant after several full pumping strokes, check the following:

1. Check container to make sure lubricant supply is sufficient.
2. Dirt or other foreign material may be preventing foot valve from seating properly.
 - A. Remove pump from container and unscrew pump tube from unit.
 - B. Remove screw from lower end of pump tube and remove ball. Clean ball and seat. Replace ball and screw.
(CAUTION: Be sure ball is in lower end of pump tube before replacing screw.)
 - C. Unscrew piston from lower end of pump rod, remove ball. Clean ball and seat thoroughly with solvent. Inspect O-ring for wear. Replace if worn.

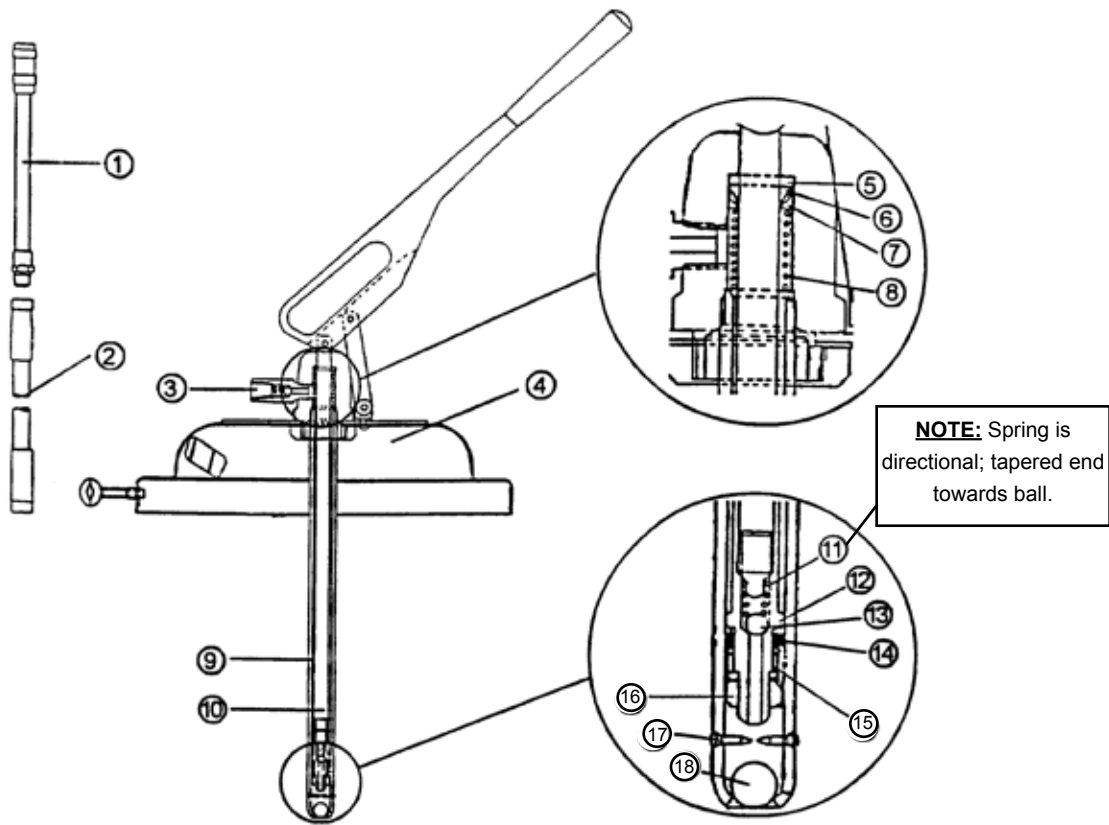

ITEM	PART#	DESCRIPTION
1	809555	Lance Assembly; 1/2-27 NPTM
2	810204	Hose Assembly; 1/2-27 NPTF (both ends)
3	809423	Ball Check; 1/2-27 NPTM (outlet)
4	821883	Cover/Handle Assembly
5	828813	O-ring
6	806812	Wiper Seal
7	807207	Back-up Ring (steel)
8	807677	Spring
9	808471	Pump Tube
10	808472	Pump Rod
11	807454	Spring (fluid piston)
12	828469	Fluid Piston
13	805810	Ball 1/4" diameter
14	829154	Wiper Seal
15	828528	Spacer Guide
16	812433	Nylok Nut
17	806844	Screw (2 required)
18	813905	Ball 1/2" diameter

Balcrank® Corporation
 Weaverville, NC 28787
 800-747-5300
 800-763-0840 (fax)
 www.balcrank.com

Revision Log:
 Rev F - Updated pressure capability
 and removed obsolete parts

For Warranty Information Visit:
www.balcrank.com

Service Bulletin SB 1018
 Rev. F 10/11