

Balcrank[®]

BOBCAT[™] 130 SERIES 1.3:1 Ratio Pump *Multi-Purpose Transfer*

Models:

1110-001	General Lube
1110-004	General Lube
1160-002	Antifreeze
1160-006	Antifreeze





Thoroughly read and understand this manual before installing, operating or servicing this equipment.

**OPERATION, INSTALLATION,
MAINTENANCE AND REPAIR GUIDE**

GENERAL SAFETY REQUIREMENTS

NOTE: THOROUGHLY READ AND UNDERSTAND THIS MANUAL BEFORE INSTALLING, OPERATING OR SERVICING THIS EQUIPMENT.

	<h3>⚠ IMPORTANT</h3>
<p>Because this pump can be incorporated into pressurized systems, the following safety precautions should be observed.</p>	
<p>Check equipment regularly and repair or replace worn and damaged parts.</p>	
<p>Never alter or modify any parts of this pump, doing so may cause damage to pump and/or personal injury.</p>	
<p>Under no circumstances should the dispensing valve be aimed at any person at any time. Personal injury may result.</p>	
<p>Release pressures built up in the system before any service or repair is begun. See the pressure relief procedure below.</p>	
<p>Do not operate this pump above 150 PSI (10.3 BAR) air inlet pressure or 300 cycles per minute.</p>	
<p>Always read and follow the fluid manufacturer's recommendations regarding the use of protective eyewear, clothing and respirators.</p>	

	<h3>⚠ WARNING</h3>
<p>PRESSURE RELIEF PROCEDURE:</p>	
<p>Follow this procedure whenever you shut off the pump, when checking or servicing any part of the system and when installing, cleaning or changing any part of the system.</p>	
<ol style="list-style-type: none"> 1) Disconnect the air to the pump. 2) Point dispensing valve away from yourself and others. 3) Open dispensing valve until pressure is relieved. 	

	<h3>⚠ WARNING</h3>
<p>THIS PUMP CONTAINS ALUMINUM AND ZINC PARTS. DO NOT use 1-1-1</p>	
<p>Trichloroethane, methylene chloride or other halogenated hydrocarbon solvents or fluids containing such solvents in this pump. Use of these solvents/fluids may result in a violent chemical reaction, causing serious bodily injury, property damage or death. All fluids used in this pump must be chemically compatible with the wetted parts materials shown on page three (3) of this manual. Consult your chemical supplier to ensure compatibility.</p>	

	<h3>⚠ WARNING</h3>
<p>Pump develops 195 PSI (13.3 BAR) maximum working pressure at 150 PSI (10.3 BAR) maximum inlet air pressure. Be sure that any components or accessories used in the system are rated to withstand this pressure. To determine fluid outlet pressure, multiply the ratio of the pump by the air pressure being used.</p>	
<p>EX: 1.3 (1.3:1 ratio) x 100 PSI = 130 PSI fluid pressure. 1.3 (1.3:1 ratio) x 6.8 BAR = 8.84 BAR fluid pressure.</p>	

	<h3>⚠ WARNING</h3>
<p>DANGER: Not for use with fluids that have a flash point below 100°F (38°C). Examples: gasoline, alcohol. Sparking could result in an explosion which could result in death.</p>	

	<h3>⚠ WARNING</h3>
<p>In the presence of explosive vapors, take action to prevent static sparking. Failure to ground the pump, piping, valves, containers, or other miscellaneous equipment can result in fire or explosion. A green grounding lug is provided on the pump.</p>	

TABLE OF CONTENTS

Cover.....	1
General Safety Information.....	2
Technical Data.....	3
Dimensional Data.....	4
Installation.....	5
Operation.....	6
Troubleshooting.....	7
Parts Listing.....	8 & 9
Pump Servicing.....	9 & 10
Accessories.....	11
Warranty.....	12

TECHNICAL DATA

Pressure Ratio.....	1.3:1
Air Pressure Operating Range.....	40-150 psi
Maximum Fluid Working Pressure.....	195 psi
Effective Air Piston Area.....	1.77 sq. in.
Effective Fluid Piston Area.....	1.38 sq. in.
Stroke Length.....	3.88 in.
Air Inlet Port Size.....	1/4" NPTF
Fluid Inlet Port Size.....	1" NPTF
Fluid Outlet Port Size.....	3/4" NPTF
Wetted Parts:	
(General Lube).....	Steel, Al, Acetal, Buna-N
(Antifreeze)....	300 Series S/Steel, Acetal, Viton
Noise Level (DBA).....	72-82
Shipping Weight: (Stub pump).....	14.5 lbs.
(Drum length).....	16.5 lbs.

PERFORMANCE/FLOW CURVES

Note: Test Fluid 10W30 Motor Oil

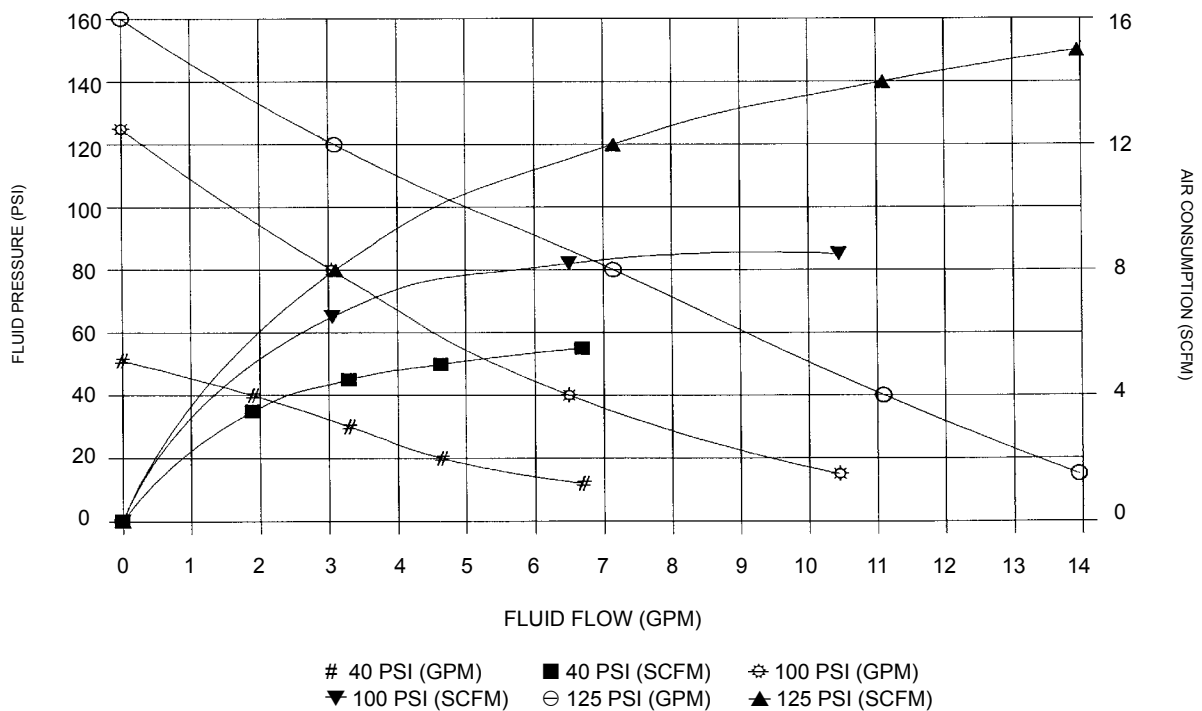

Figure 1
Flow Curves

PRODUCT DESCRIPTION

The “Bobcat™ 130” pump family replaces the earlier “Trans-Jet 130”, “131A-CB & 131A-CBL”, “121”, “Econo-Jet”™ (1.5:1) and P-160/P-161 food pumps. These pumps are suitable for petroleum products, chemicals, and USDA applications.

Four versions are currently available, two each in stub and drum lengths. The 1110-001 and 1110-004 are composed of carbon steel parts with Buna-N seals for long life.

The 1160-002 and 1160-006 have all “wetted parts” made from 304 SS or 316 SS and Viton and are USDA approved.

All pumps contain a pair of 1 inch Delrin® balls which provide compatibility for many fluids and a smooth flow on both pump strokes. For fluids more viscous than 90W gear lube, carbon steel or 300-series SS balls may be substituted.

All pumps are composed of a 2-piece body with the upper section being Aluminum and the lower section being Aluminum or 316 SS, depending on model number.

The lower section’s flanged coupling contains a 4-hole bolt pattern which allows 360° rotation of the inlet and outlet ports in 90° degree increments. This feature is useful when installing a pump on a wall bracket that limits orientation of the hoses.

All pumps contain a pair of internal exhaust mufflers which provide efficient operation with low noise levels conforming to OSHA regulations. These mufflers also act as filters, inhibiting air line debris from exiting the pump where cleaner environments are required.

The 1-piece pump air motor is factory-lubricated with a life-tested, synthetic grease (Balcrank #826733). This grease coats all internal parts and repels air line moisture to inhibit corrosion. Steel components exposed to air line moisture are surface treated to inhibit corrosion.

NOTE: Delrin® is a registered trademark of the DuPont Company

DIMENSIONS & MOUNTING DIAGRAM

Figure 2
Pump Dimensions

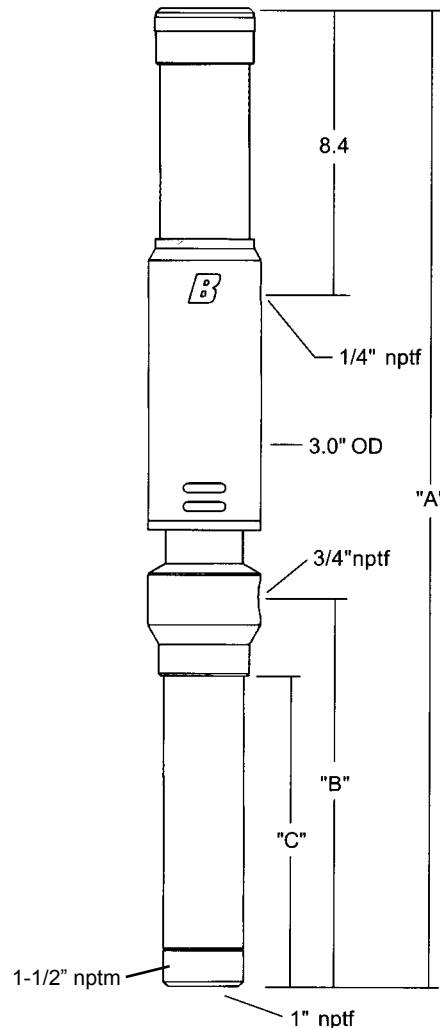

MODEL	OVERALL LENGTH		
	"A"	"B"	"C"
(Stub Length)			
1110-001	26.2"	9.8"	8.2"
1160-002	26.2"	9.8"	8.2"
(Drum Length)			
1110-004	50.4"	34.0"	32.4"
1160-006	50.4"	34.0"	32.4"



WARNING: Attach a proper ground wire to the Bobcat's grounding lug (item 40) before starting the pump.

INSTALLATION

Remove pump from carton and attach to cover, bung fitting or other mountings.

Blow out any foreign material from the air supply line before connecting to pump. An air line filter/regulator is recommended for all applications; wet and dirty air will shorten the life of the pump.

NOTE: For severe duty applications, an air line lubricator is recommended for better performance and longer pump life. Use an SAE 10 oil and set the lubricator for 2 drops per hour.

Be sure the air supply is OFF before connecting accessories and/or pump.

NOTE: *DO NOT* hang Filters/Regulators/Lubricators or other equipment of this type directly from pump air inlet. The fittings are not strong enough to support the weight and may cause one or more to leak and/or break. A bracket should be used to support the use of these products.



CAUTION

If you are not using a low-level cut-off at the pump fluid intake, install a pump runaway valve to shut off the air to the pump, when the pump accelerates beyond the pre-adjusted setting. A pump that runs too fast can be seriously damaged.

1. Install an air line regulator to control pump speed and air pressure for the system.
2. Install an air line filter to remove and trap contaminants that could cause unwanted wear and tear on pump air motor.
3. Install a quick disconnect coupler to relieve air pressure between the pump air motor and regulator for servicing purposes later.
4. Install fluid hose, making note of fluid and pressure compatibility of hose.

TYPICAL INSTALLATIONS

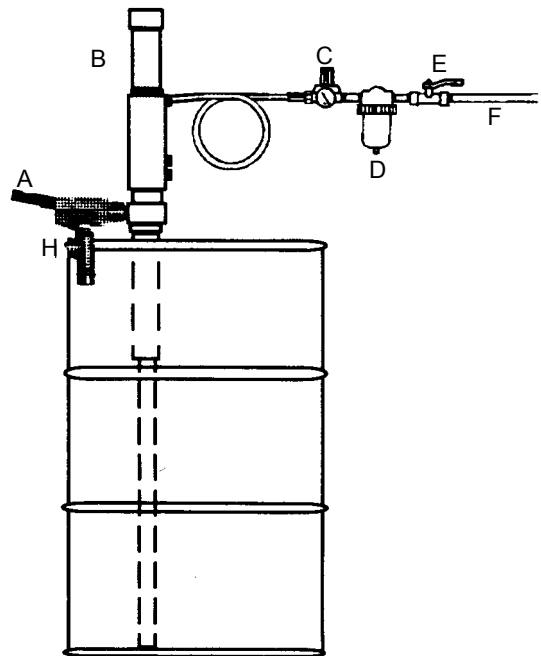

Figure 3
Drum Installation

- A Fluid Outlet
- B 1.3:1 Ratio Pump
- C Air Regulator
- D Air Filter/Separator
- E Shut Off Valve
- F Air Supply
- H Pressure Relief Valve

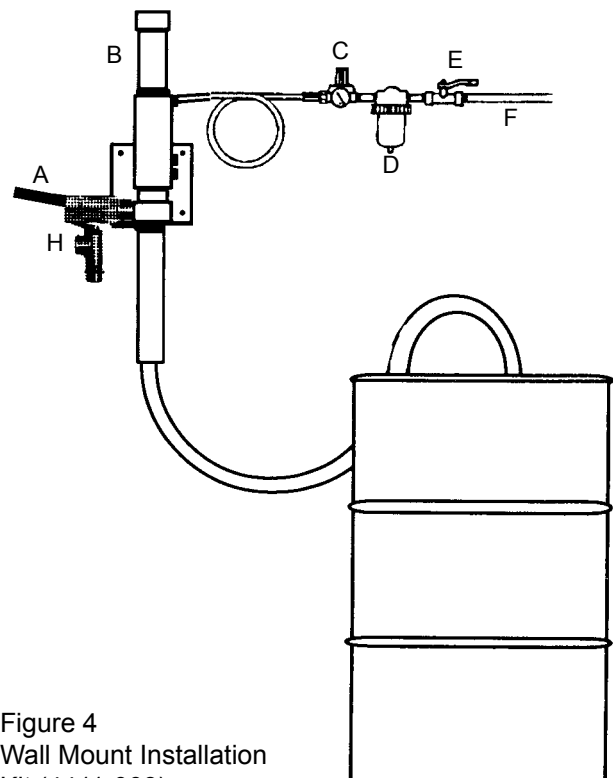

Figure 4
Wall Mount Installation
Kit (4411-008)

OPERATION

NOTE: All fluids used in this pump must be chemically compatible with the materials used to manufacture the “wetted parts”. Consult your chemical supplier to ensure compatibility.

TO START PUMP:

1. Connect air coupler to pump and turn the air regulator to the minimum setting.
2. Direct outlet hose into an approved waste oil container.
3. Slowly adjust air regulator until pump is primed and is running smoothly. Be sure all air has been purged from system. The pump should only take a few strokes to prime. However, in a large system, it may take longer.
4. Use the air regulator to control the pump speed and cycle rate. Always use the lowest pressure needed to obtain the desired flow rate. This will increase pump and seal life!
5. Never allow a pump to run dry of the fluid being pumped. A dry pump quickly speeds up and can damage the air motor. If it speeds up, shut off air supply immediately. Refill the supply container and prime the pump to eliminate air in the fluid line.

NOTE: To prevent air from being sucked into the pump and fluid lines, if the supply container should run dry, use a low-level cutoff valve (4411-010) at the pump fluid intake.

6. Read and follow the instructions supplied with each component in your system.
7. If the pump will be unattended for any period of time, or to shut off the system at the end of the work shift, *always* follow the **Pressure Relief Procedure**.

	WARNING
	Pump develops 195 PSI (13.3 BAR) maximum working pressure at 150 PSI (10.3 BAR) maximum inlet air pressure. NEVER exceed the maximum working pressure of the lowest rated equipment of your system.

	WARNING
	PRESSURE RELIEF PROCEDURE: Follow this procedure whenever you shut off the pump, when checking or servicing any part of the system and when installing, cleaning or changing any part of the system. 1) Disconnect the air to the pump. 2) Point dispensing valve away from yourself and others. 3) Open dispensing valve until pressure is relieved.

TROUBLESHOOTING GUIDE

NOTE: Check all other possible causes before disassembling the pump.

TROUBLE	PROBABLE CAUSES	REMEDY
Pump does not operate	Inadequate air supply pressure or restricted air line Clogged fluid lines, hoses, valves, etc. Damaged air motor Empty fluid supply	Increase air supply; clear ⁽¹⁾ Open; clear ⁽¹⁾ Service/replace air motor Refill, reprime and/or flush
Air motor not tripping over	Air motor o-rings are worn/damaged	Service/replace air motor
Air leaking from exhaust	Worn or damaged air motor o-ring and/or seal, etc.	Service/replace air motor
Fluid leaking from exhaust	Seal (30) is worn and/or damaged	Replace
Erratic pump operation	Air entering suction line Fluid level too low Air motor icing	Check for loose connections Refill, reprime or flush Run pump at lower pressure; run at lower cycles per minute; clean mufflers
Pump runs "wild"	Empty fluid supply Blockage in pump tube or footvalve Lower ball (14) is stuck in footvalve Lower seal (16) on fluid piston is worn or damaged	Refill, reprime or flush Remove pump tube; clean blockage Replace ball and reseal footvalve Replace with new seal
Fluid output on one stroke only or continues to operate when dispensing valve is closed	Retainer (38) is broken (ball floats with fluid) Upper ball (14) is lodged in piston (15)	Service and replace Service and replace
Pump operates, but output low on both strokes	Inadequate air supply pressure or restricted air lines Closed or clogged solenoid valve, meter, dispensing valve, etc. Empty fluid supply Air inlet strainer/filter clogged	Increase air supply; increase delivery line size Clear ⁽¹⁾ Refill, reprime or flush Clear ⁽¹⁾

(1) Follow the **Pressure Relief Procedure**, on page 6 and disconnect the fluid line. If the pump starts when the air is turned on again, the line, etc. is clogged.

Pump Schematic Bobcat™ 130 Series 1:1 Ratio Pump

This assembly used on Stainless Steel Model Nos. 1160-002 and 1160-006.

This assembly used on Carbon Steel Model Nos. 1110-001 and 1110-004.

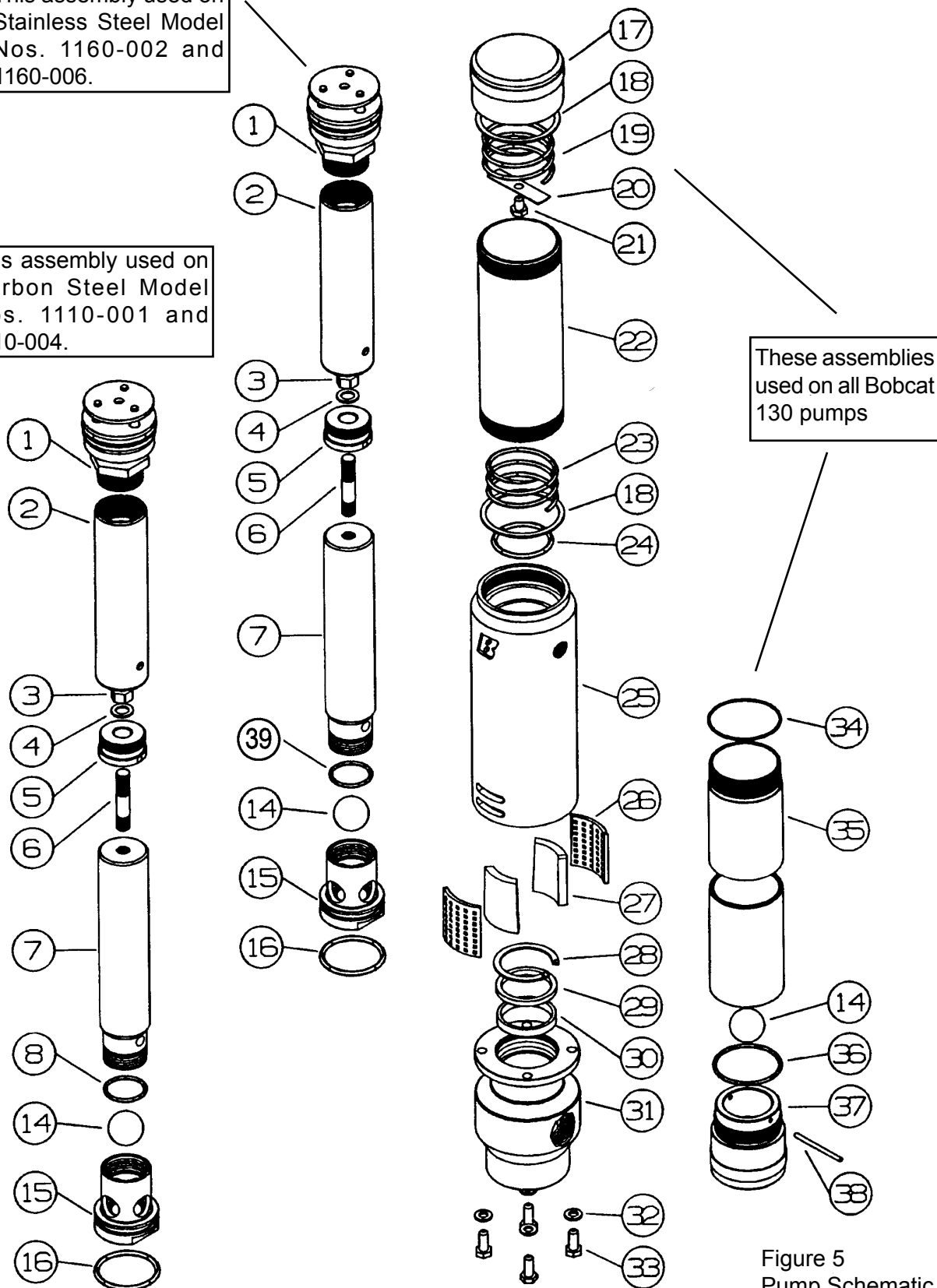



Figure 5
Pump Schematic

Parts List			1110-001	1160-002	1110-004	1160-006
ITEM	PART #	DESCRIPTION				
1	827710	Air Valve Assembly	1	1	1	1
2	826658	Upper pump rod	1	1	1	1
3	805723	Crimp Nut	1	1	1	1
4	805756	Washer	1	1	1	1
5	826052	Adapter	1	1	1	1
6	826680	Rod	1	1	1	1
7	827414	Lower Pump Rod (Alum.)	1	1	1	1
	827415	Lower Pump Rod (316SS)		1		1
8	820015	O-Ring, Buna-N, -120**	1		1	
	827441	O-Ring, Viton, -120***		1		1
9		Not Used				
10		Not Used				
11		Not Used				
12		Not Used				
13		Not Used				
14	827168	1" Ball (Delrin)** ***	2	2	2	2
15	827422	Fluid Piston (Alum.)	1		1	
	828988	Fluid Piston (316SS)		1		1
16	816853	O-Ring, Buna-N, -223**	1		1	
	827065	Quad-Ring, Viton, -325***		1		1
17	826660	Cap (Alum.)	1	1	1	1
18	828529	Flat Gasket*	2	2	2	2
19	826663	Spring*	1	1	1	1
20	826664	Spring Retainer	1	1	1	1
21	826665	Screw, 1/4-20 x 1/2"	1	1	1	1
22	827727	Air Piston Tube (STL)	1	1	1	1
23	808439	Spring*	1	1	1	1
24	807342	O-Ring, Buna-N, -222*	1	1	1	1
25	827780	Upper Body (Alum.)	1	1	1	1
26	827767	Muffler Screen (Brass)	2	2	2	2
27	827766	Muffler Foam** ***	2	2	2	2
28	827426	Retaining Ring	1	1	1	1
29	827425	Backup Ring (Brass)	1	1	1	1
30	826071	Wiper Seal, Buna-N**	1		1	
	826072	Wiper Seal, Viton***		1		1
31	828365	Lower Body (Alum.)	1		1	
	828366	Lower Body (316SS)		1		1
32	829002	Lock Washer (STL)	4	4	4	4
33	829001	Screw, 1/4-20 x 3/4"	4	4	4	4
34	826678	O-Ring, Buna-N, -132**	1		1	
	826679	O-Ring, Viton-132***		1		1
35	828361	Pump Tube, (STL), 6.8"	1			
	831205	Pump Tube, (316SS), 6.8"		1		
	828362	Pump Tube, (STL), 31"			1	
	831206	Pump Tube, (316SS), 31"				1
36	826678	O-Ring, Buna-N, -133**	1		1	
	826679	O-Ring, Viton, -132***		1		1
37	826060	Footvalve, (STL)	1		1	
	829027	Footvalve, (316SS)		1		1
38	827427	Retaining Pin (316SS)** ***				
		(prior to 6/03 on carbon pumps)	1	1	1	1
	829769	Retaining Pin**				
		(after 6/03 on carbon pumps)	1	1	1	1
39	831489	Grounding Lug (not shown)	1	1	1	1



! WARNING

PRESSURE RELIEF PROCEDURE:
Follow this procedure whenever you shut off the pump, when checking or servicing any part of the system and when installing, cleaning or changing any part of the system.

- 1) Disconnect the air to the pump.
- 2) Point dispensing valve away from yourself and others.
- 3) Open dispensing valve until pressure is relieved.

PUMP SERVICING

NOTE: Air motor is lubricated with a life tested synthetic grease (Balcrank® P/N 826733) at the factory. This grease coats all parts and repels air line moisture to inhibit corrosion. It is imperative that any grease removed during routine maintenance be replaced. Contact your local Balcrank® Distributor, using the above part number, for replacement grease.

NOTE: The following steps and item numbers pertain to the stub pumps. Except for a few fluid section components (pump tube, pump rod, fluid piston, etc.), stub and drum pumps are alike. When repairing a drum pump, pay close attention to different parts that may carry the same item number as their stub counterparts, such as the pump tube (35).

Repair Kits: There are three kits available to repair the stub and drum "Bobcat 130" pumps:

- * 827711 (air piston parts for all pumps)
- ** 828069 (fluid seals for carbon steel pumps)
- *** 828070 (fluid seals for stainless steel pumps).

PUMP SERVICING

Pump Disassembly: This operation must be performed before continuing to the following sections. See page 11 for applicable repair kits.

Grip the upper pump body (25) in a padded-jaw or smooth-jaw vise. Unscrew air piston tube (22), with cap (17) attached, from the upper body. Unscrew the pump tube (35), with footvalve (37) attached, from the lower body (31).

Place a 1/4" diameter rod through hole at the bottom of the lower pump rod (7). Use an adjustable wrench to unscrew the fluid piston (15) from the pump rod. Remove ball (14) and set aside. Grip air motor assembly (1) by hand and pull out the entire assembly (air motor and both pump rods). Wrap the pump rods to prevent damaging the surfaces. Keep the lower spring (23) with the rod.

Upper Body O-ring Replacement: O-ring (24) can be removed by using a curved pick or small-bladed screw driver. Wipe o-ring groove to remove debris and replace.

Lower Body Seal Replacement: This seal must be replaced each time the lower rod is pulled through the body.

The wiper seal (30) is replaced by removing screws (33) and washers (32) and separating the upper (25) and lower (31) body sections. Use snap ring pliers to remove the retaining ring (28). Remove the backup ring (29) and seal (30). Apply Balcrank lubricating grease (p/n 826733) to the seal area and install a new seal flared side down. Work carefully to avoid seal tearing around the snap ring groove. Reassemble in reverse order.

Lower Spring and Air Motor Replacement: Replace the spring (23) by sliding off the old spring and sliding on the new part. The air motor (1) is a 1-piece, staked assembly that cannot be disassembled for repair of internal o-rings or upper seal. Replace the entire assembly using Balcrank Repair Kit 827711.

Wrap the upper pump rod (2) with protective material or use wood/plastic blocks to grip it in a vise. Use a wrench to remove the air motor assembly at the hex adaptor (1) pump rod (2) joint. **Note:** If the upper pump rod needs replacement, do so before the new air motor is installed (refer to Replacing the Upper Pump Rod). Apply thread adhesive to the air motor before installation.

Upper Spring and Flat Seal Replacement: Unscrew cap (17) from air piston tube (22). Remove screw (21), spring retainer (20) and spring (19) and lift out upper gasket (18). Reassemble in reverse order.

Replace the lower gasket (18) while the tube is off the body (25). Be sure the new gasket is flat against the body before assembling the tube

Replacing Parts in the Footvalve: Grip pump tube (35) and footvalve (37) with separate strap wrenches. Unscrew the footvalve, drive out retainer pin (38) with a 1/8" diameter punch, remove lower ball (14) and/or o-ring (36) as necessary. When reassembling the pump tube to the lower pump body, be sure to check the upper o-ring (34) for damage and replace as necessary. Apply grease to the footvalve threads and o-rings (34,36) and reassemble.

Replacing the Upper Pump Rod: Grip only the upper rod in a vise. Use a 1/8" spanner wrench to remove the floating joint adapter (5) and air motor assembly (1) from the upper rod. Wrap the replacement upper rod in protective material before placing in the vise. Apply thread adhesive to both internal threads of the pump rod and reassemble the connecting parts.

Replacing the Lower Pump Rod: Grip only the lower rod in a vise. Use a 1/8" spanner wrench to remove the floating joint adapter (5) from the upper rod (2). Wrap the upper rod and air motor assembly and set aside.

Use an adjustable wrench to remove lock nut (3). Slide off washer (4) and adapter (5). Remove connecting rod (6) with a pipe wrench. Wrap replacement lower rod in protective material before placing in the vise. Apply thread adhesive to the connecting rod (6) and reassemble with the short thread length into the rod. Replace the washer (4), adapter (5) and nut (3). Tighten nut completely then back off 1/4-turn to allow free movement of adapter. Apply thread adhesive to the adapter and reassemble.

Pump Reassembly: Apply grease to the lower pump rod end, wiper seal (30) and o-ring (24). Slide the lower spring (23) over the upper pump rod and then slide the entire upper rod/lower rod/air motor assembly through the pump. Some resistance will be encountered as the lower rod passes through the wiper seal (30). Reinstall the upper ball (14) and piston (15). Insert a 1/4" diameter rod through the pump rod and tighten the fluid piston with a wrench. File off any burrs or raised areas created during the repair process.

Grease o-rings (16,34) and pump tube (35) threads before reassembling to the body. Tighten with a strap wrench. Grease the air motor assembly and inside the tube (22), reassemble and tighten with a strap wrench

ACCESSORIES

Air Regulators

3260-028	1/4" nptf (mini)
3260-029	1/4" nptf
3260-030	3/8" nptf

Air Filter/Regulators

3260-033	1/4" nptf (mini)
3260-034	1/4" nptf
3260-035	3/8" nptf

Pump Over-Run Controls

3241-001	1/2" nptf
3241-002	1/4" nptf

In-Line Hand Operated Valves

3230-003	300 psi (air), 1/4" nptf
3230-002	2,000 psi, 1/2" nptf

Spigot & Tube Kit

4410-009

- Gooseneck spigot
- 1" npt telescoping suction tube
- Air hose, 3/8" x 5'
- Air coupler and nipple
- Bung Adapter

Telescoping Suction Tube

4412-012

- 1" npt (fits 55 gal drum and 250 gal tank)

Hose & Tube Kit

4410-011

- 1" npt telescoping suction tube
- Air hose, 3/8" x 3'
- Fluid hose, 3/4" npt x 5'
- Air coupler and nipple
- Bung Adapter

Universal Bung Adapter Kit

- 4411-009 (carbon steel pumps)**
- 4411-017 (stainless steel pumps)**

- Universal bung adapter mounts all Bobcat 130 pumps to 2" npt bung threads and wall mount brackets

Foot Mount Adapter Kit

- 4411-018 (carbon steel stub pumps)**

- Mounts carbon steel stub pumps to 2" npt bung threads.

Quality Checklist

- Bill of Material checked for current content.
- Pump was tested and met Balcrank performance standards.

I _____
certify that this product meets or exceeds
Balcrank's high quality standards.

Revision Log:

Rev. A - Added pin 829769 (item 38)
Added Grounding Lug (item 40)

WARRANTY

All Balcrank® equipment sold by authorized Balcrank® distributors is warranted to their original customer to be free from defects in materials and workmanship for a period of one year from the date the equipment was sold to the original customer. Select equipment carries extended warranty terms as individually noted within the Balcrank® Lubrication Equipment & Accessories User Price List. Any Balcrank® equipment carrying an extended warranty will be warranted for the period indicated; those items carrying a "lifetime" warranty are warranted for a period of thirty years. All Balcrank® equipment determined by Balcrank® to have defective materials or workmanship within the one year warranty period will be repaired or replaced. For equipment carrying extended warranties Balcrank® will repair or replace the product including parts and labor for the first full year and will provide parts only for the remaining period of the specified warranty.

This warranty only covers equipment installed and operated according to applicable Balcrank® Service Bulletins and Installation Instructions. Any equipment claimed to be defective must be returned, freight prepaid, to an Authorized Balcrank® Service Center. If the part(s) or equipment is found to be defective, it will be repaired or replaced, and returned freight prepaid from the Authorized Service Center. If the claimed part(s) or equipment is found not to be defective, the Authorized Balcrank® Service Center will, upon written authorization being received from the original customer, repair them for a reasonable charge to the customer which will include all applicable parts, labor, and return transportation costs. Any equipment returned to Balcrank® must have the Warranty Service Claim number (WSC#) clearly marked on the outside of the carton. Balcrank's sole responsibility is for defects in material and workmanship, and Buyer's sole and exclusive remedy hereunder, shall be limited to repair or replacement of the defective part or equipment.

This warranty does not cover, nor shall Balcrank® be liable for repair or replacement of parts or equipment resulting from general wear and tear through use, or damage or failure caused by improper installation, abuse, misapplication, abrasion, corrosion, insufficient or improper maintenance, negligence, accident, alteration, or substitution of non-Balcrank component parts. Furthermore the Balcrank® Warranty for Lubrication Equipment and Accessories does not cover the following specific conditions:

- Failure or damage to equipment that is caused by dirt or debris in air and fluid lines. This includes, but is not limited to clogged inlet filters, strainers, or regulators; fluid meters; control handles; fluid tips; and valves.
- Failure of normal wear parts including but not limited to: "o"-rings, packings, seals and valves unless originally improperly installed by the factory.
- Products placed in applications for which their use was not intended. Examples include but are not limited to: A lubricant pump being used to pump solvents, or placing a piece of equipment intended strictly for indoor use in an outdoor application.
- Damage to equipment resulting from operation above and beyond Balcrank's recommendations.
- Leaks at air and fluid fittings and connections.
- Damage caused by thermal expansion when adequate pressure relief was not included in the system.
- Loose suction tubes on pumps.
- Reel spring tension adjustment.

THERE ARE NO OTHER WARRANTIES, EXPRESSED OR IMPLIED, INCLUDING WARRANTIES OF MERCHANTABILITY OR FITNESS FOR A PARTICULAR PURPOSE. IN NO EVENT SHALL BALCRANK BE LIABLE FOR ANY SPECIAL, CONSEQUENTIAL, OR OTHER DAMAGES OF SIMILAR NATURE, INCLUDING BUT NOT LIMITED TO LOST PROFITS, LOST PRODUCTION, PROPERTY DAMAGE, PERSONAL INJURY, WHETHER SUFFERED BY BUYER OR ANY THIRD PARTY, IRRESPECTIVE OF WHETHER CLAIMS OR ACTIONS, LEGAL OR EQUITABLE, FOR SUCH DAMAGES ARE BASED UPON CONTRACTS, WARRANTY, NEGLIGENCE, STRICT LIABILITY, OR OTHERWISE. ANY CLAIM OR ACTION FOR BREACH OF WARRANTY MUST BE BROUGHT WITHIN TWO (2) YEARS FROM THE DATE OF SALE TO THE ORIGINAL CUSTOMER.

PRODUCT EXTENDED WARRANTY

Bobcat™ 130 Series Pumps are warranted to be free from defects in material and workmanship for a period of five years from date installed in service by the original purchaser. Normal wear of items such as packings or valve seats are not considered to be defects in material or workmanship.

Balcrank® Corporation
Weaverville, NC 28787
800-747-5300
800-763-0840 Fax
www.balcrank.com

Distributed by: