

Balcrank®

Lion HP® 50:1 Grease Pump Series

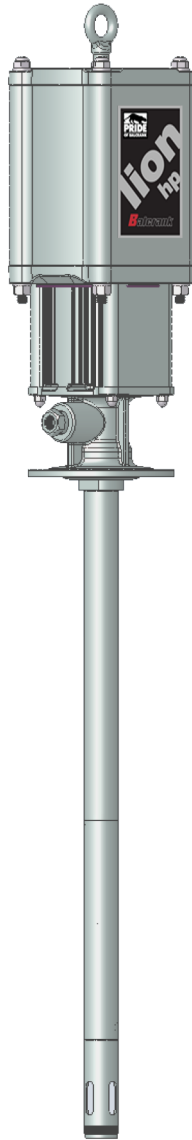

Model #	Pump Version
1150-015	400lb. Drum
1150-018	Tote Stub

Thoroughly read and understand this manual before installing, operating or servicing described equipment.

Operation, Installation, Maintenance and Repair Guide

General Safety

Thoroughly read and understand this manual before installing, operating or servicing the described products.



IMPORTANT

Because this pump can be incorporated into a pressurized systems, the following safety precautions should be observed.

Check equipment regularly and repair or replace worn and damaged parts.

Never alter or modify any parts of this pump, doing so may cause damage to pump and/or personal injury.

Under no circumstances should the dispensing valve be aimed at any person at any time. Personal injury may result.

Release pressures built up in the system before any service or repair is begun. See the pressure relief procedure below.

Do not operate this pump above 150 PSI (10.3 BAR) air inlet pressure or 200 cycles per minute.

Always read and follow the fluid manufacturer's recommendations regarding the use of protective eye wear, clothing and respirators.



WARNING

WARNING: The Lion HP® 50:1 pump (1150-015,-018) develops 7500 psi (517 Bar) maximum working pressure at 150 psi (10.3 Bar) maximum inlet air pressure and stall conditions. Be sure that any components or accessories used in the system are rated to withstand this pressure. To estimate fluid output pressure at stall conditions, multiply the ratio of the pump by the air pressure being used.

EXAMPLE: 50:1 Pump Ratio x 100 psi air pressure = 5000 psi fluid pressure at stall.



WARNING

Pressure Relief Procedure:

Follow this procedure whenever you shut off the pump, when checking or servicing any part of the system and when installing, cleaning or changing any part of the system.

- 1) Disconnect the air to the pump.
- 2) Point dispensing valve away from yourself and others.
- 3) Open dispensing valve until pressure is relieved.



DANGER

Not for use with fluids that have a flash point below 100°F (38°C). Examples: gasoline, alcohol. Sparking could result in an explosion which could result in death.



WARNING

Use 3241-001 Pump Over-Run control valve on pump air inlet for remotely operated pumps. Failure to use this valve can cause pump to cycle quickly when barrel is empty of grease. **THIS WILL DAMAGE THE PUMP** and may void factory warranty.



WARNING

In the presence of explosive vapors, take action to prevent static sparking. Failure to ground the pump, piping, valves, containers, or other miscellaneous equipment can result in fire or explosion. A green grounding lug is provided on the pump.

Table of Contents

Cover.....	1	Pump Repair/Service.....	5-8
General Safety Information.....	2	Troubleshooting Guide.....	9
Product Description.....	3	Parts List.....	10
Technical Data.....	3	Parts Diagrams.....	11-16
Pump Installation.....	4	Pump Dimensions.....	17
Operation.....	4	Warranty Statement.....	20
Preventive Maintenance.....	5		

Product Description

The 50:1 ratio Lion HP® Pump is suitable for simultaneous fluid distribution to multiple dispense points, or for pumping to distances of up to 300 feet.

The Lion HP® air motor features a precision air valve mechanism with dual valve ports for improved high speed breathing. It also contains a positive trip detent spool mechanism that eliminates stalling (blowing air) by preventing the pump from stopping between strokes. It has a simple yet durable construction with all internal parts lubricated at the factory using a life-tested synthetic grease.

The Lion HP® pumping assembly features a stainless pump rod for superior wear and corrosion resistance. The pump's exterior is constructed from aircraft grade aluminum for an outstanding strength and reliability. The pump also has high quality seals and is designed for long-term durability and ease of service. It also features a double action grease pumping assembly, which provides volume delivery on both strokes.

Operating Noise Level

85 DbA @ 100 psi air and 8 lbs/min



NOTE: This pump has been tested and found conforming to OSHA operating noise limits when used for intended purpose (grease dispensing, intermittent duty cycles).

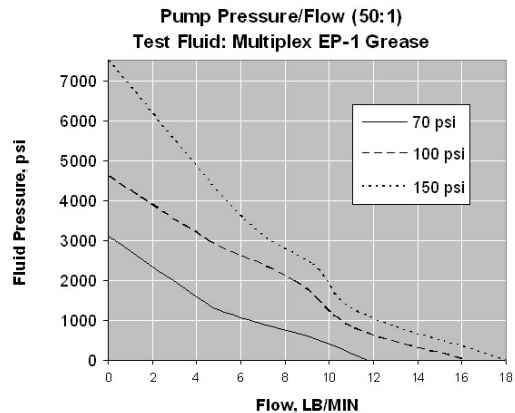

Technical Data

Lion HP® 50:1 Ratio Pump

Specification Item	Value or Range
Nominal Pump Pressure Ratio	50:1
Air Motor Effective Piston Diameter	4.25 inches [107 mm]
Nominal Pump Stroke Length	3.25 inches [81.3 mm]
Air Motor Displacement	91.9 cubic inches [1.51 liters]
Pump Cycles per Pound @ 100 psi air	20-24 cy/lb [55-67 cyc/kg]
Maximum Operating Air Pressure Range	10 - 150 psi [0.7-10.3 Bar]
Recommended Operating Air Pressure Range	40 - 125 psi [2.8 - 8.6 Bar]
Fluid Stall Pressure @ 150 psi air	7550 psi [521 Bar]
Approx. Air Consumption, 8 lbs./min. @ 100 psi air	72 SCFM
Port Size, Fluid Out	3/8" NPT(F)
Port Size, Supply Air	1/2" NPT(F)
Wetted Parts	Carbon Steel, Ultrathane, Brass, Stainless Steel
Compatible Fluids	No. 2 Petroleum Grease

Pump Installation



WARNING: Attach a proper ground wire to the pump grounding lug (item 62) before starting the pump.



CAUTION: Performance will be affected by a suction path seal (follower plate) that is not air tight.

To insure proper performance of your grease pump, Balcrank® recommends using a follower plate if mounting the pump to a grease drum.

Using four 3/8"-16 bolts and lock washers, secure the pump to the drum cover. Slide the follower plate up the pump tube and attach optional screen assembly. Insert pump (with follower plate) into drum and tighten thumb screws.

Tighten one end of outlet hose to pump outlet. Secure control handle to the other end of the outlet hose.

Install a coupler or a ball valve into the pump's air intake port. Attach a F-R-L onto the pump. Fill the lubricator with 10-20 wt. lubricant - set for 1 drop every 2 hours. Connect compressed air to F-R-L and set regulator to no more than 150 psi (10 Bar).

Open control handle into suitable container to properly prime pump and remove air from system.

Preventive Maintenance

The Lion® grease pump has been designed to operate dependably with little required maintenance. However, to ensure pump longevity, the following should be observed:

- Keep the grease free of trash and debris. Periodically check the pump inlet for foreign matter and clean when necessary.
- Run the pump at the minimum pressure required to achieve the desired flow rate (*less than 125 psi and 150 cyc/min recommended*).
- Ensure the pump receives clean, moisture free air. Check and maintain the system's air filter on a regular basis.
- Although the air motor is coated with synthetic grease upon factory assembly and can run without lubricated air, Balcrank recommends an in-line F.R.L. be installed in the pumping system.
- Never let the pump run dry of the grease being pumped.



Figure 1
Installed Lion HP® Pump

Pump Operation



CAUTION: Read all limitations which apply to selection of grease which may be pumped by this product. Do not pump a grease which is not specified to be compatible.



CAUTION: Always read and follow fluid manufacturers' recommendations regarding proper use of protective eye wear, clothing and respirators.

To Start Pump:

- 1 Immerse the pump's suction tube inlet into the grease to be pumped.
- 2 Connect the air coupler to the pump and turn the air regulator to the minimum setting.
- 3 Direct pump outlet hose into an approved waste oil container.
- 4 Slowly adjust the air regulator until the pump is primed and running smoothly. Be sure all air has been purged from the system. The pump should prime in less than 30 seconds.
- 5 Use the air regulator to control the pump's speed and cycle rate. Always use the lowest pressure required to obtain the desired flow rate. This will increase pump and seal life.
- 6 Never allow a pump to be run dry of the grease being pumped. A dry pump quickly speeds up, which could damage the air motor and fluid seals. If the pump suddenly speeds up, cut off the air supply as soon as possible, refill the reservoir with grease and reprime the pump.
- 7 If the pump will be unattended for any period of time, or to shut off the system at the end of a work shift, always follow the Pressure Relief Procedure on page 2 of this manual.



WARNING

Pressure Relief Procedure:

Follow this procedure whenever you shut off the pump, when checking or servicing any part of the system and when installing, cleaning or changing any part of the system.

- 1) Disconnect the air to the pump.
- 2) Point dispensing valve away from yourself and others.
- 3) Open dispensing valve until pressure is relieved.



NOTE: The air motor is lubricated with a life-tested synthetic grease (P/N 826733) at the factory. This grease coats all parts and repels air line moisture to inhibit corrosion. It is imperative that any grease removed during maintenance be replaced afterwards. Contact your local Balcrank distributor, using the above part number, for replacement grease.

Pump Repair / Servicing

Pump Disassembly Procedure:

Figure 11

- 1 Mount the pump horizontally in a bench vise. Clamp the vise to the upper body of the pump and use elastic jaw cushions in the vise to prevent scarring the pump surface. With a socket wrench, loosen and remove the four lower 5/16" Hex Bolts [14] and Lock Washers [12]. Then remove and set aside the Bare Lower subassembly. Also remove the Lower Body [4], Muffler [17], and Diffuser Plate [16].
- 2 If the air motor subassembly will not be repaired immediately, re-attach the Lower Body [4], Muffler [7], and Diffuser Plate [16] to the Air Motor subassembly, temporarily securing them with the 5/16" Bolts [14] and Lock Washers [12], turned hand tight. Remove the assembly from the vise.
- 3 For further disassembly, use the separate procedures which follow for the Air Motor and Lower Pump subassemblies.

Air Motor Disassembly Procedure:

Figure 5

- 4 If the Lower Body [4], Muffler [17], and Diffuser Plate [16] are attached to the Air Motor subassembly,

remove them now, along with the four 5/16" Hex Bolts [14] and Lock washers [12] which secure them.

5 Mount the Air Motor horizontally in a bench vise. Clamp the vise to the Upper Body [2] of the pump and use elastic jaw cushions in the vise to prevent scarring the pump surface.

6 Using a socket wrench, hold the 1/2" Hex Bolt [7] on the pump Cap [1]. With a second socket wrench, loosen and remove the 1/2" Hex Nut [10] and Lock washer [9] at the other end of the 1/2"-13 Bolt [7]. Repeat the procedure for the other three Bolts. Set aside all fasteners in a group.

7 Remove the Center Insert [3] from the subassembly by sliding it carefully off the Air Piston. Remove the two O-ring Seals, [5] and [26], from their glands on the Center Insert [3]. Set these parts aside in a group.

8 Remove the Cap [1] from the top of the Air Motor. As the Cap [1] is removed, it must be shifted sideways approximately 1 inch to allow detachment from the internal Trip Rod. After removal of the Cap, remove the O-ring Seal [5] from the gland in the Cap. Set these parts aside in a group.

9 Remove the Air Motor Subassembly [shown in figure 4] from the Upper Body [2]. Remove toward the top of the pump, opposite the direction of the 1/2" NPT port on the Upper Body. Slide out carefully, keeping the Air Piston square with the bore of the Upper Body. Remove the Upper body from the vise and set aside.

Figure 4

10 Remove the O-Ring Seal [6] from the Air Piston [18]. Using a flat blade screwdriver, remove two Detent Sleeves [29], Detent Springs [28], and Detent Balls [27]. Set all of the removed parts aside as a group.

11 Clamp the Air Piston in a vise applied to the 6" piston diameter. Note! Use Split wooden vise blocks matched to the piston diameter to prevent scarring the piston surface!

12 Using two open-end wrenches, loosen the Jam Nuts [25] located on top of the Intake Valve Stems [22]. Remove the Jam Nuts and the two Intake Valve Stems. It may be necessary to secure the hex cap of the Valve Stem [22] with an open end wrench while removing the second nut. Then remove the O-Ring Seals [24] from the gland of the two Valve Stems [22].

13 Remove the Valve Trip Assembly [shown in figure 3] from the top of the Air Piston. Remove the Air Piston plus Rod Coupler, items [18] and [19], from the vise and set aside. Note! It is not necessary

to separate the joint of the Air Piston and Coupler.

Figure 3

14 Secure the assembly horizontally in a bench vise, clamping the parts at the flats located on the Rod Head [33]. Applying torque to the flats of the Retainer, Spring, Threaded [34], loosen the trip rod assembly. Note! Turn wrench slowly and steadily to prevent breaking male threads on the Trip Rod [32].

15 Remove all parts from the Trip Rod [32]. Using vise-grip pliers, clamp the Trip Rod [32] near the Rod Head [33] and loosen the remaining threaded joint. Set aside all loose parts in a group, but retain the Valve Bar parts [shown in Figure 2] for further disassembly.

Figure 2

16 Using two open-end wrenches, loosen the Jam Nuts [25] located on top of the Exhaust Valve Stems [23]. Remove the Jam Nuts and the two Exhaust Valve Stems. It may be necessary to secure the hex cap of the Valve Stem [23] with an open end wrench while removing the second nut. Then remove the O-Ring Seals [24] from the gland of the two Valve Stems [23].

17 Clamp the subassembly in a vise on the flats of the Nut [15]. Using an adjustable open-end wrench, loosen the Detent Spool [20]. Separate all parts. Set aside all items from steps 16 and 17 in a group. Disassembly of the Air Motor is now complete.

Lower Pump Disassembly Procedure:

Figure 10

1 Clamp the subassembly shown in figure 10 in a bench vise, holding the parts at the flat edge of the flange of the Fluid Adapter [38]. Place a 5/16" punch thru the slats of the Primer Cylinder [46] and thru the hole in the Primer Rod [54]. Using a 1/2" socket remove Nut [59]. Slide Piston [58] off of Primer Rod [54]. Using a strap wrench, remove Primer Cylinder [46]. Set these parts aside after removal.

Figure 9

2 With the Fluid Adapter [38] still clamped in the bench vise, remove the Primer Valve [60]. Using a strap wrench remove Pump Tube [44 & 45] together by sliding them out of the Adapter [38]. Use care to avoid scarring the surface finish on the o.d. of the Pump Rod. Using snap ring pliers, remove Retainer Ring [61]. Seal [57] and Seal Retainer [56] can be removed. Set aside the Primer Valve parts and Tubes.

Figure 8

3 Using a 5/16" punch and a pipe wrench, detach the Upper Rod [48] from the Lower Rod [49]. Set all parts aside.

Figure 7

4 Place a 5/16" punch in a bench vise. Slide the Lower Rod [49] onto the punch. Separate Primer Rod [54] from High Pressure Piston [55] with a 5/16" punch and a 3/8" spinner wrench. Separate High Pressure piston [55] from Piston Nut [51] with two 3/8" spinner wrenches. Separate Piston Nut [51] from Lower Rod [49] with 3/8" spinner wrench. Set all parts aside from figure 7 as a group.

Figure 6

5 Clamp the Seal Adapter [39] on the flats in a bench vise. Using an adjustable wrench, remove the Port Extension [47]. Using a pipe wrench, remove the Fluid Adapter [38]. With an adjustable wrench, unscrew Seal Carrier [40] from Seal Adapter [39]. Pull Upper Rod [48] out of Seal Adapter [39]. Slide Rod Guide [42], Seal [43], and Seal Retainer [41] off of Upper Rod [48]. Set all parts aside. Disassembly of the Pump Lower is now complete.

Lower Pump Assembly Procedure:

Figure 6

1 Collect the parts group shown in figure 6. Substitute rebuild kit parts in place of old items where applicable. Clamp the Seal Adapter [39] on the flats in a bench vise. Apply a film of grease to the o.d. of the Upper Rod [48]. Install the Seal Retainer [41], Seal [43], and Rod Guide [42] onto the Upper Rod [48]. Insert the Upper Rod [48] into the Seal Adapter [39]. Secure with Seal Carrier [40].

2 Attach Fluid Adapter [38]. Re-install Port Extension [47]. Set this subassembly aside.

Figure 7

3 Collect the parts group shown in figure 7. Place a 5/16" punch in a bench vise. Slide the Lower Rod [49] onto the punch. Attach Piston Nut [51] with Lower Rod [49] with a 5/16" punch and a 3/8" spinner wrench. Connect High Pressure piston [55] to Piston Nut [51] with two 3/8" spinner wrenches. Connect Piston Nut [51] to Lower Rod [49] with 3/8" spinner wrench. Set this subassembly aside.

Figure 8

3 Collect the parts group shown in figure 8. Clamp Fluid Adapter [38] in the bench vise. Attach Upper

Rod [48] to Lower Rod [49].

Figure 9

4 Substitute rebuild kit parts in place of old items where applicable. With the Fluid Adapter [38] still clamped in the bench vise, install the Upper Tube [44] using a strap wrench. Apply a film of grease to the o.d. of the Lower Rod [49] and slide Primer Valve [60] onto Lower Rod [49]. Use care to avoid scarring the surface finish on the o.d. of the Lower Rod.

Figure 10

5 With the Fluid Adapter [38] still clamped in the bench vise, install Primer Cylinder [46] using a strap wrench. Insert Piston [58] and secure with Nut [59]. Lower Pump Assembly is now complete.

Air Motor Assembly Procedure:

Figure 2

1 Collect the parts group shown in figure 2. Substitute rebuild kit parts in place of old items where applicable. Install the Valve Bar [21] on the mating diameter of the Detent Spool [20]. Clamp the 5/8" Jam Nut [15] in a bench vise on the flats of the Nut and apply Loctite 638 thread lock to the internal threads of the Jam Nut [15]. Then, Using an adjustable open-end wrench, install and tighten the Detent Spool [20]. Apply 85 in-lb torque.

2 Install the Exhaust Valve Stems [23] into the Valve Bar [21]. Apply Loctite 638 thread lock to the internal threads of the 5/16" Jam Nuts [25] and install on the stems [23] and tighten to 70 in-lbs using two open-end wrenches. It will be necessary to secure the hex cap of the Valve Stem [23] with an open end wrench while securing the first nut. Then install the O-Ring Seals [24] into the gland of the two Valve Stems [23].

Figure 3

3 Secure the Rod Head [33] in a bench vise, clamping the part across the flats. Apply Loctite 263 to the internal threads. Install the Trip Rod [32] and tighten to 40 in-lb torque. Use vise grips, applied near the Rod Head, to turn the Trip Rod.

4 Install the following items onto the Trip Rod [32] in the sequence and orientation shown in figure 3: Spring Retainer [14, qty=3], Trip Spring [15, qty=2], assembled parts from stage 1, figure 2.

5 Apply Loctite 263 to the internal threads of the Spring Retainer, Threaded [34]. Install the Spring Retainer, Threaded on the end of the Trip Rod [32] and tighten the entire assembly to 100 in-lbs torque.

Figure 4

7 Clamp the Air Piston [18] in a vise, with clamping pressure applied to the 6" diameter on the piston. Note! Use Split wooden or elastic vise blocks matched to the piston diameter to prevent scarring the piston surface!

8 Apply a film of grease in the center cavity of the Air Piston [18]. Insert the assembled parts from assembly stage 2 (per figure 3) into the cavity, oriented as shown in figure 4.

9 Apply a film of grease to the seal gland and o.d. surfaces of the Intake Valves [22]. Install O-Ring Seals [24] on the Intake Valves. Then pass the valves through the ports of the Air Piston [18] and into the mating holes on the Valve Bar [21]. Secure the Valves with 5/16" Jam Nuts [25]. Tighten all Jam Nuts to 70 in-lb torque.

10 Apply a film of grease to the 1/2" Ball [27, qty=2] and Detent Spring [28, qty=2]. Then by hand, apply upward pulling force on the Trip Rod assembly, so that the intake valves [22] are completely closed. With the Trip Rod held in that position, install the 1/2" Steel Ball [27], Detent Spring [28] and Detent Sleeve [29] in each of the two detent ports located on the Air Piston [18]. It will be necessary to unclamp and adjust position of the Air Piston during this procedure.

11 Apply a film of grease to the o.d. seal gland on the Air Piston [18], then install the O-Ring Seal [6]. Remove the Air piston from the vise and apply a film of grease to the 6" diameter piston surface. Set aside the completed subassembly.

Figure 5

12 Clamp the Upper Body in a bench vise, oriented with bore horizontal. Use elastic jaw cushions in the vise to prevent scarring the pump surface. Install the Air Motor Subassembly [shown in figure 4] into the Upper Body [2]. Install from the top of the pump, opposite the direction of the 1/2" NPT port on the Upper Body. Slide in carefully, keeping the Air Piston square with the bore of the Upper Body.

13 Install the O-ring Seal [5] into the gland in the Cap [1]. Install the Cap [1] on the top of the Air Motor. When the Cap [1] is installed, it must be shifted sideways approximately 1 inch to allow attachment of the internal Rod Head [33, fig 2] into the slot on the Cap [1].

14 Apply a film of grease to the seal glands on the Center Insert [3]. Install the two O-ring Seals, [5] and [26], in their glands on the Center Insert

[3]. Install the Center Insert [3] on the subassembly by sliding it gently onto the Air Piston.

15 Install the Bolts [7, qty=4] as shown in figure 5, into the holes on the subassembly. Using a socket wrench, hold the 1/2" Bolt [7] on the pump Cap [1]. With a second socket wrench, install the 1/2" Hex Nut [10, qty=4] and Lock washer [9, qty=4] at the other end of the 1/2"-13 Bolt [7] and tighten. Leave the Upper Body clamped in the bench vise.

Final Pump Assembly Procedure:

Figure 11

16 Install the Lower Body [4] in position on the Air Motor (from figure 5), with Dowel Pins on the Lower Body oriented away from the Air Motor. Install the Muffler [17] and Diffuser Plate [16] in the counterbore of the Lower Body [4].

17 Install the Bare Lower subassembly on the Air Motor as shown in figure 11. The muffler must be loosened, Pump Rod, muffler, and diffuser plate shifted off-center 1", then moved into position and the Pump Rod locked into the coupler slot on the bottom of the Air Piston. After attachment to the Air Piston, reposition the muffler and diffuser plate then move the flange of the Fluid Adapter into tight contact with the Lower Body. Install the 5/16" Bolts [14] and Lock washers [12], then tighten to 100 in-lb torque. Pump assembly is complete.

Troubleshooting Guide



NOTE: Check all other possible causes of operating problems, and apply remedial action, before disassembling pump.



WARNING: Before beginning pump repair, all internal pressure must be relieved. To reduce risk of personal injury, follow the Pressure Relief Procedure shown on pages 2 and 5.

Trouble	Probable Cause	Corrective Action
Pump does not operate	Inadequate air supply pressure or restricted air line Clogged lines, hoses, valves, etc. Damaged air motor	Increase line size or clear air supply ⁽¹⁾ Assure air is on and valves are open Open; clear ⁽¹⁾ Service / replace air motor
Air motor is not tripping over	Air motor seals are worn/damaged	Service / replace air motor / Insure a filter is used on air inlet to pump
Air is leaking from exhaust and or seal damage, etc.	Air motor seals are worn/damaged	Service / replace air motor Insure a filter is used on air inlet to pump
Fluid is leaking from the exhaust	Fluid seal [43, fig 8] is worn/damaged	Replace fluid seal
Erratic pump operation	Air entering suction line Fluid level too low Air motor icing cycles per minute; clean muffler [17]	Check follower plate Refill, reprime or flush Run pump at lower pressure; run at lower
Pump runs continuously	Empty fluid supply Blockage in primer tube [46] Ball [52] is stuck in piston nut [51] Lower seal [53] is worn or damaged	Refill, reprime or flush Remove primer tube, clear blockage Replace ball and reseal piston nut Replace
Pump operates slowly, and pump output on both strokes is low	Inadequate air supply pressure or restricted air line Closed or clogged dispensing valve Air inlet strainer/filter clogged	Increase air supply; increase air supply size Clear ⁽¹⁾ Clear ⁽¹⁾

(1) Follow the **Pressure Relief Procedure** and disconnect the fluid line. If the pump starts when the air is turned on again, the line, etc. is clogged.

Parts List
Lion HP® 50:1 Ratio Pump
1150-015 400lb. Drum
1150-018 Stub Tote

Service Kits
900029 Pump Lower Rebuild Kit
900027 Air Motor Rebuild Kit (*see note)
900028 Air Motor Soft Parts Kit (*see note)

Item	Part Number	Description	Pump Quantity		Service Kit Quantity		
			1150-015	1150-018	900029	900027	900028
1	831791	Cap	1	1			
2	833253	Upper Body	1	1			
3	831793	Center Insert	1	1			
4	831795	Lower Body	1	1			
5	830659	Seal, O-Ring, -258	2	2		2	2
6	806909	Seal, O-Ring, -433	1	1		1	1
7	833526	Bolt, 1/2-13	4	4			
8		No Longer Used					
9	805841	Washer, Lock, 1/2	4	4			
10	805813	Nut, Hex, 1/2-13	4	4			
11		No Longer Used					
12	805844	Washer, Lock, 5/16	4	4			
13		No Longer Used					
14	833527	Bolt, 5/16-18	4	4			
15	831366	Nut, Hex Jam, 5/8-18	1	1		1	
16	832228	Diffuser Plate	1	1			
17	832105	Muffler	1	1			
18	831799	Air Piston	1	1			
19	831913	Coupler Rod	1	1			
20	831660	Spool, Detent	1	1		1	
21	831759	Valve Bar	1	1		1	
22	831761	Valve Stem, Intake	2	2		2	
23	831762	Valve Stem, Exhaust	2	2		2	
24	831665	Seal, O-Ring, Polymod, -110	4	4		4	4
25	831764	Nut, Hex Jam, 5/16-18	8	8		8	
26	831367	Seal, O-Ring, -345	1	1		1	1
27	813905	Ball	2	2		2	
28	807939	Spring	2	2		2	
29	831914	Sleeve, Detent	2	2		2	
30	831766	Spring	2	2		2	
31	831767	Retainer, Spring	3	3		3	

*Additional parts in kit. Kit is also used for Tiger HP & Lion HP oil pumps.

Parts List
Lion HP® 50:1 Ratio Pump
1150-015 400lb. Drum
1150-018 Stub Tote

Service Kits
900029 Pump Lower Rebuild Kit
900027 Air Motor Rebuild Kit (*see note)
900028 Air Motor Soft Parts Kit (*see note)

Item	Part Number	Description	Pump Quantity		Service Kit Quantity		
			1150-015	1150-018	900029	900027	900028
32	831768	Trip Rod	1	1		1	
33	831769	Rod Head	1	1		1	
34	831770	Retainer, Spring, Threaded	1	1		1	
35	830641	Label, Lion	1	1			
36	830350	Label, Warning	1	1			
37	832114	Lifting Eye	1	1			
38	832117	Fluid Adapter, Lion HP 50:1	1				
	832256	Fluid Adapter, 50:1, Stub Tote		1			
39	832132	Seal Adapter	1	1			
40	832135	Seal Carrier	1	1			
41	832134	Seal Retainer	1	1	1		
42	832133	Rod Guide	1	1	1		
43	830678	Seal, Ultrathane	1	1	1		
44	832131	Pump Tube - 400lb. drum	1				
	832254	Pump Tube - Stub Tote		1			
45	832128	High Pressure Cylinder	1	1			
46	832127	Primer Cylinder	1	1			
47	830676	Port Extension	1	1			
48	832116	Upper Rod	1	1			
49	832126	Lower Rod - 400lb drum	1				
	832255	Lower Rod - Stub Tote		1			
50	808324	Spring	1	1	1		
51	832125	Piston Nut	1	1			
52	806167	Ball	1	1			
53	830679	Seal, Ultrathane	1	1	1		
54	832123	Primer Rod	1	1			
55	832124	High Pressure Piston	1	1			
56		Seal Retainer**			1		
57		Seal, Ultrathane**			1		
58		Primer Valve**					
59		Retaining Ring**					
60	832833	Seal Case Assembly	1	1			
61	812166	Piston	1	1			
62	805715	Nut, Hex 1/2-20	1	1			
63	831489	Grounding Lug (not shown)	1	1			

** Items 56, 57, 58, and 59 are contained in item 60 (832833 - seal case assembly)

*Additional parts in kit. Kit is also used for Tiger HP & Lion HP oil pumps.

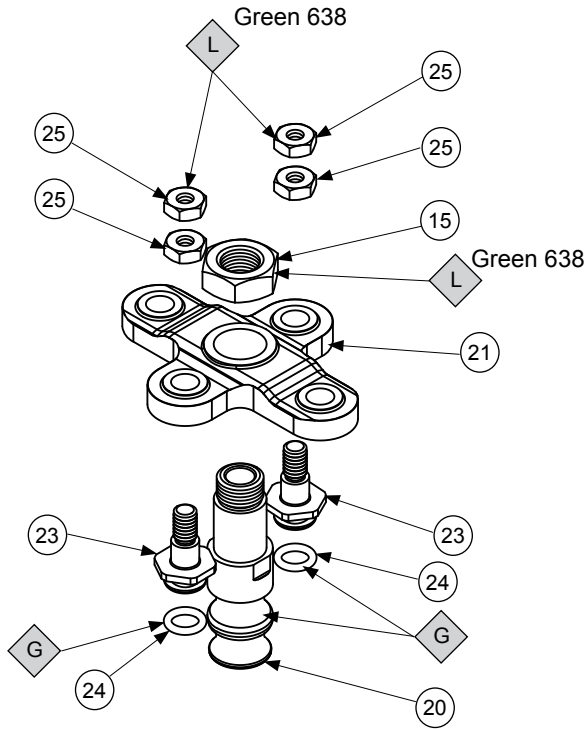

Figure 2
Head Assembly
Assembly Stage 1

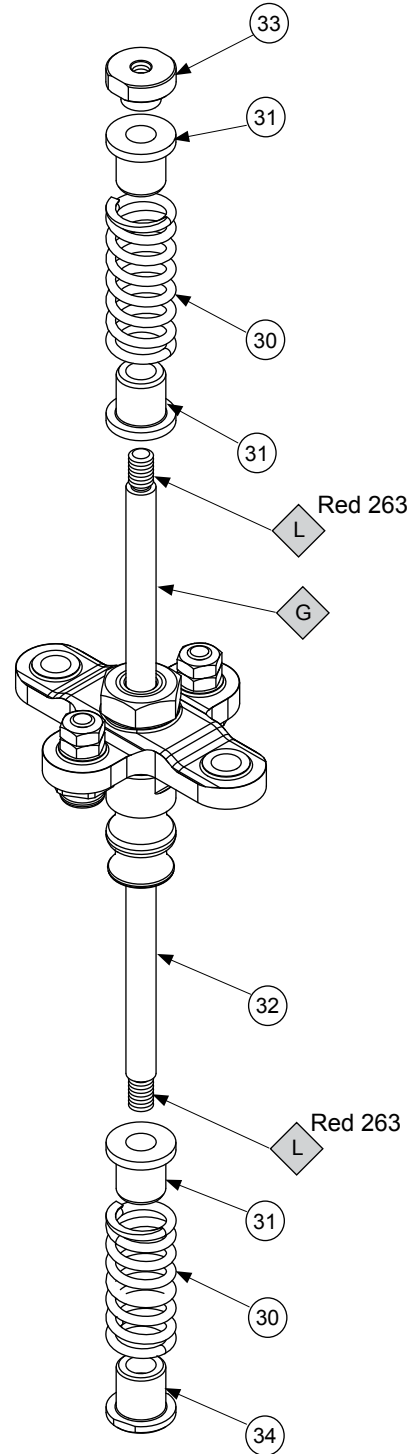
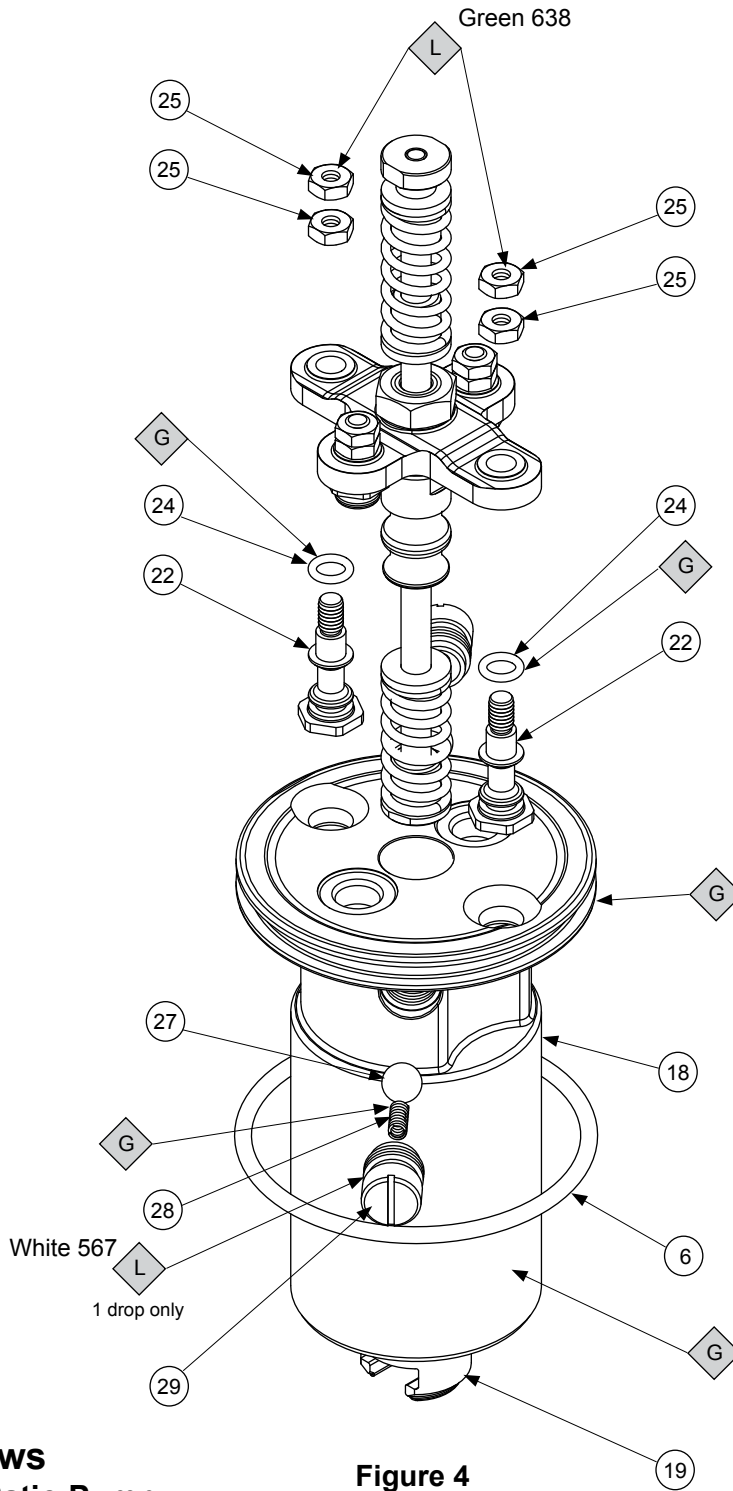

Figure 3
Head Assembly
Assembly Stage 2

Exploded Views
Lion HP® 50:1 Ratio Pump
1150-015
1150-018
Air Motor

- (25) - Item number, see page 10
- G - Grease application point, see detail in written procedure
- L - Loctite application point, see detail in written procedure



Exploded Views
Lion HP® 50:1 Ratio Pump
1150-015
1150-018
Air Motor

Figure 4
Head Assembly
Assembly Stage 3

- (25) - Item number, see page 10
- G - Grease application point, see detail in written procedure
- L - Loctite application point, see detail in written procedure

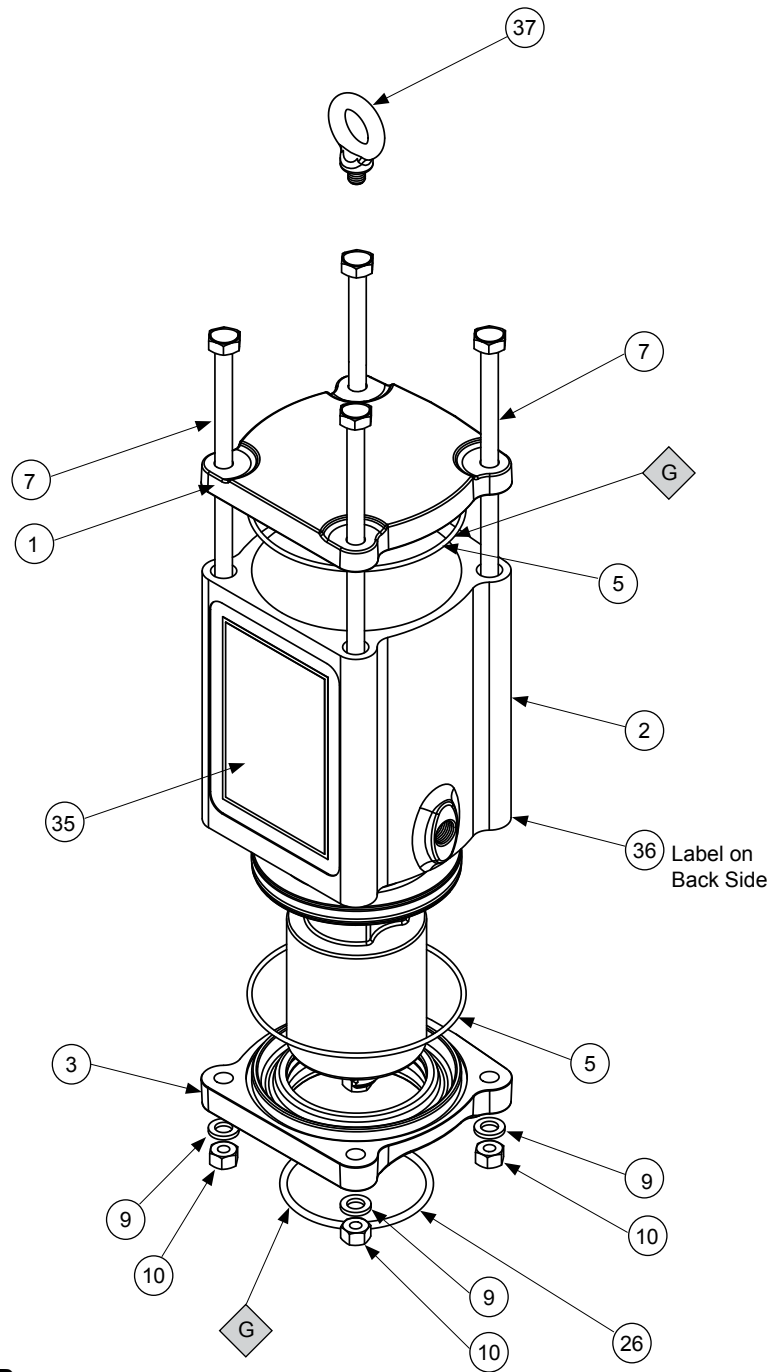

Exploded Views
Lion HP® 50:1 Ratio Pump
1150-015
1150-018
Air Motor

- 25 - Item number, see page 10
- G - Grease application point, see detail in written procedure
- L - Loctite application point, see detail in written procedure

Figure 5
Head Assembly
Assembly Stage 4

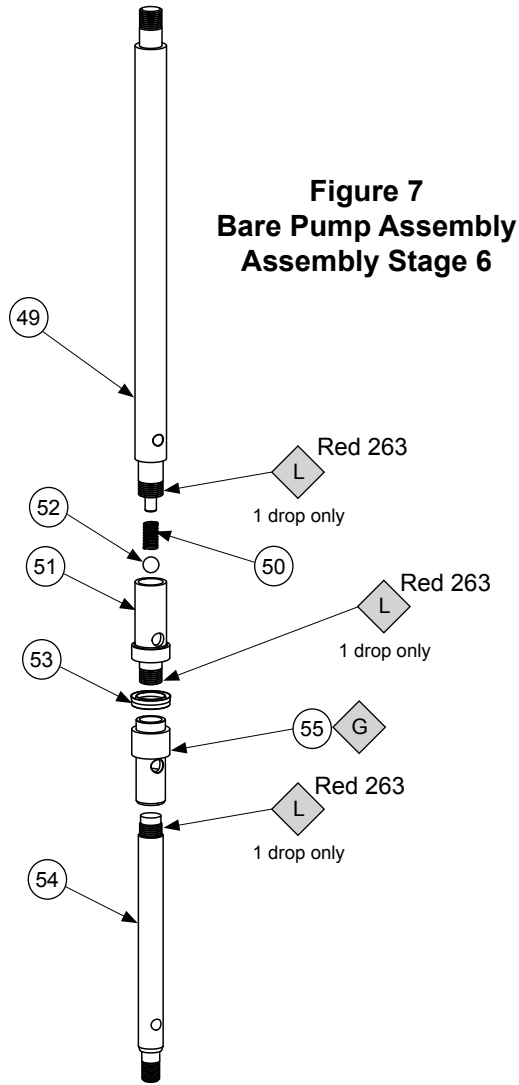

**Figure 7
Bare Pump Assembly
Assembly Stage 6**

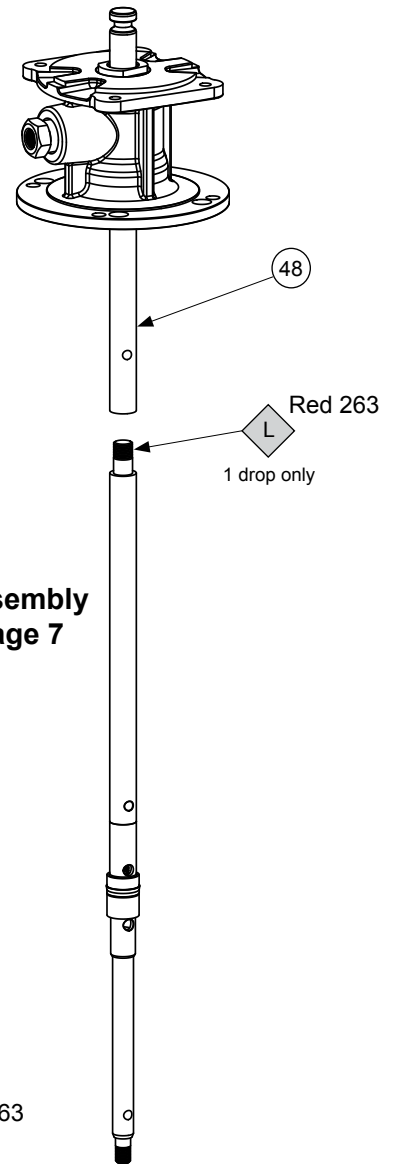

**Figure 8
Bare Pump Assembly
Assembly Stage 7**

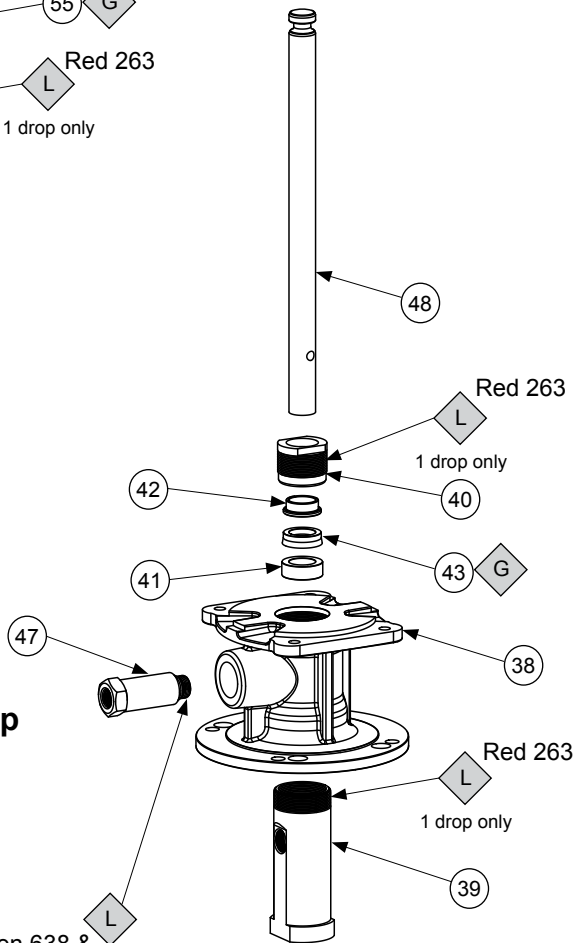

**Figure 6
Bare Pump Assembly
Assembly Stage 5**

**Exploded Views
Lion HP® 50:1 Ratio Pump
1150-015
1150-018
Lower Assembly**

- 25 - Item number, see page 10
- G - Grease application point, see detail in written procedure
- L - Loctite application point, see detail in written procedure

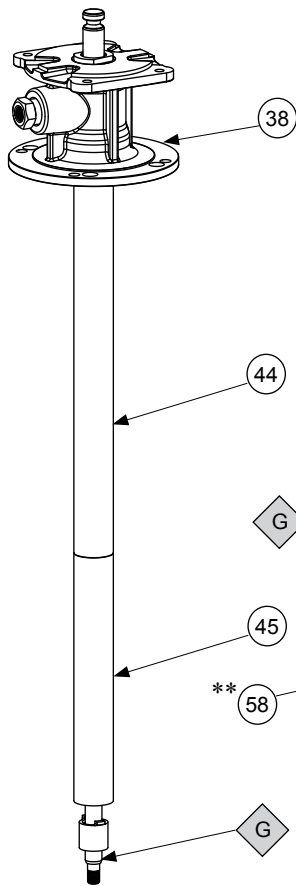

Figure 9
Bare Pump Assembly
Assembly Stage 8

** Items 56, 57, 58, and 59 are contained in item 60 (832833 - seal case assembly)

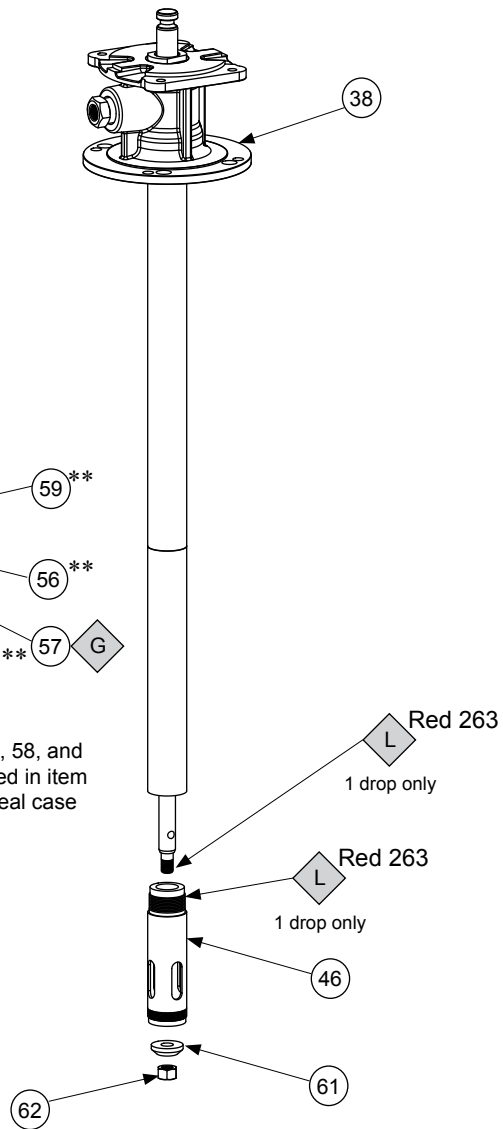

Figure 10
Bare Pump Assembly
Assembly Stage 9

Exploded Views
Lion HP® 50:1 Ratio Pump
1150-015
1150-018
Lower Assembly

(25)	- Item number, see page 10
G	- Grease application point, see detail in written procedure
L	- Loctite application point, see detail in written procedure

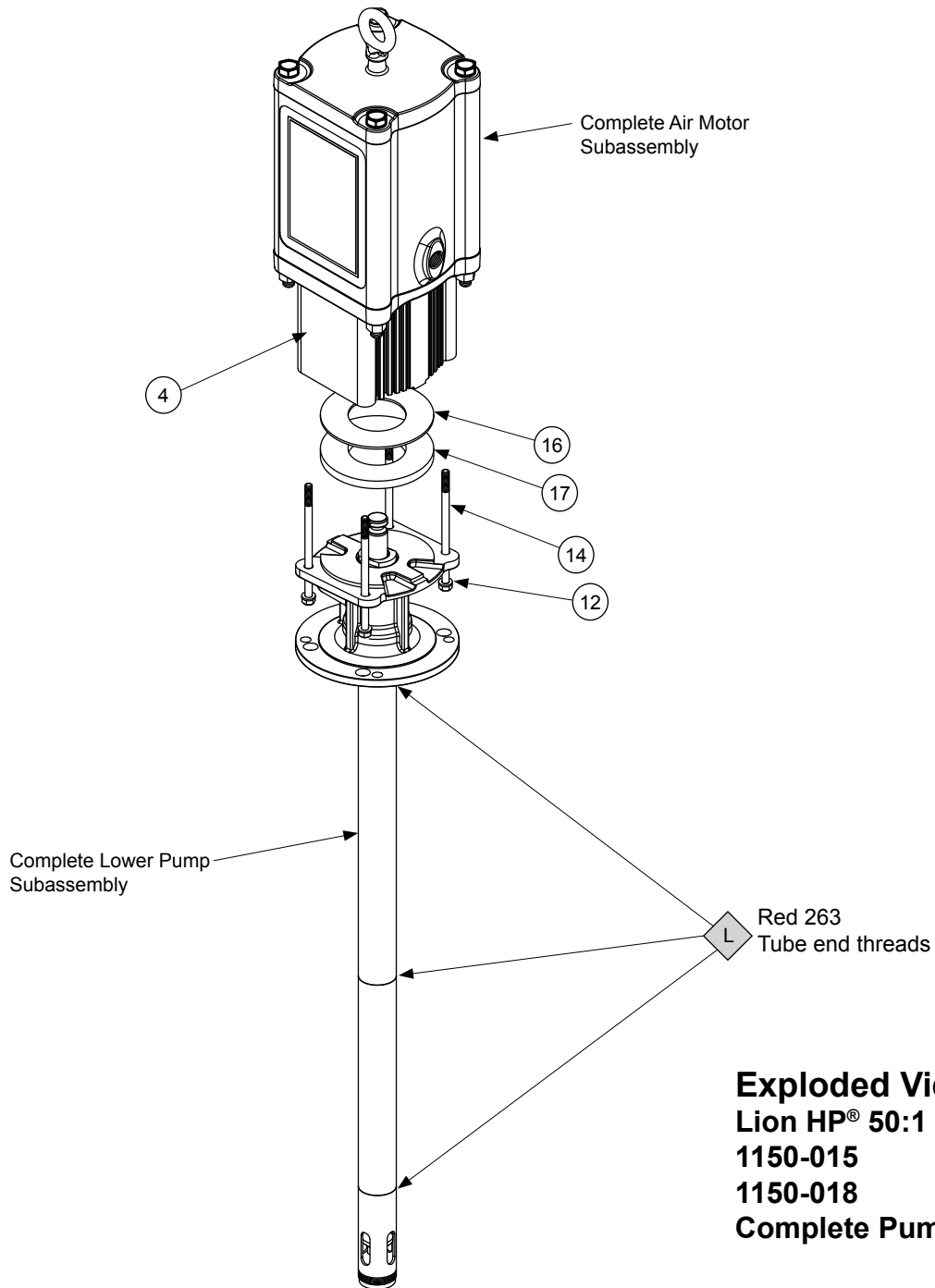

Figure 11
Final Pump Assembly
Assembly Stage 10

Exploded Views
Lion HP® 50:1 Ratio Pump
1150-015
1150-018
Complete Pump

- | | |
|----|--|
| 25 | - Item number, see page 10 |
| G | - Grease application point, see detail in written procedure |
| L | - Loctite application point, see detail in written procedure |

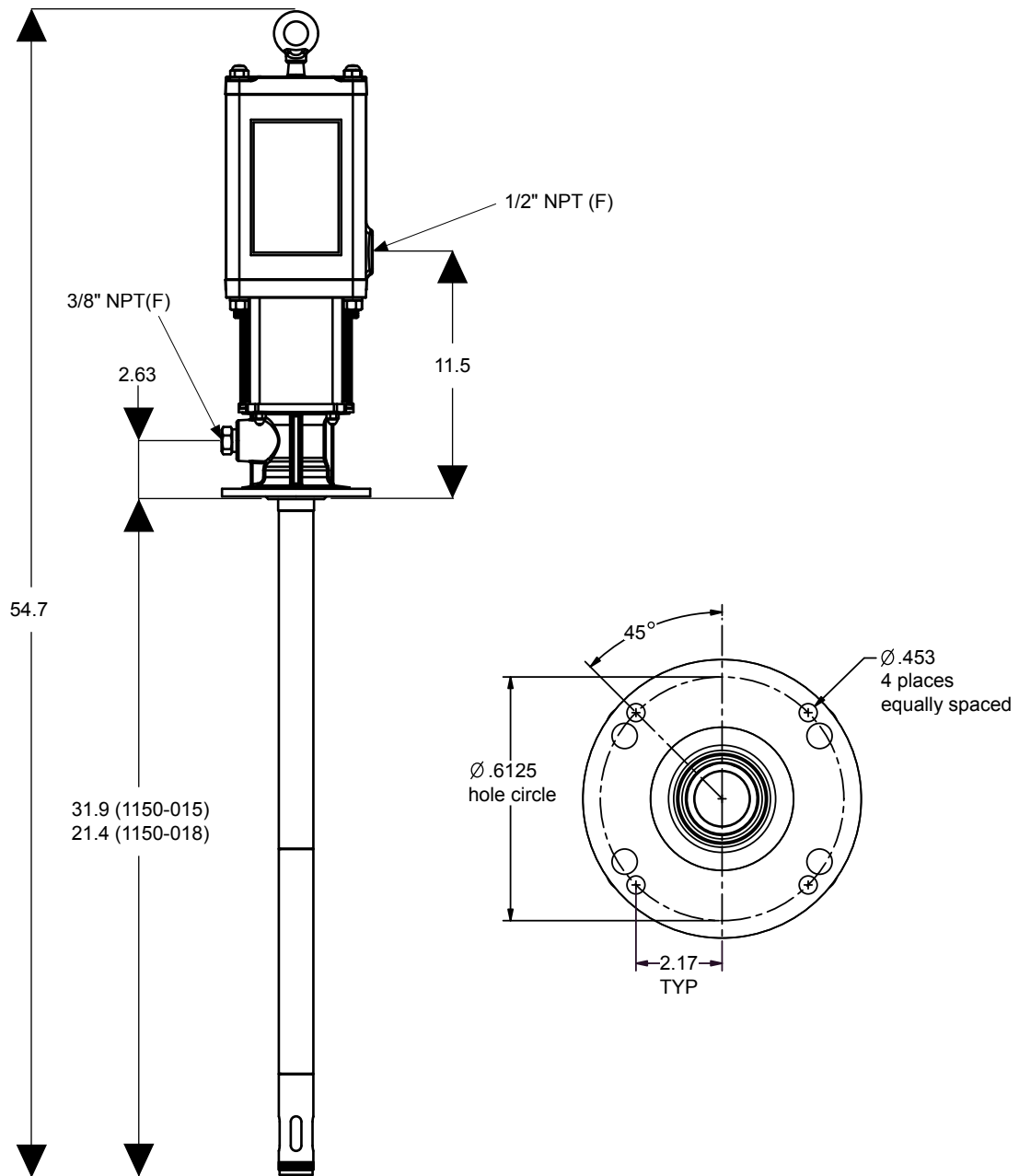

Figure 12
Complete Pump
Dimensions & Features

Lion HP® 50:1 Ratio Pump
Complete Pump
1150-015
1150-018

Revision Log:

New Release - 7/06

Rev A - Added Tote Stub Model 1150-018

Rev B - Updated item number 16

Rev C - Added note about kits 900027 & 900028 to pages 10 & 11 and updated warranty statement

Rev D - Changed part number for item 2 in parts list

Rev E - Added part number 832833 (seal case assembly) to pages 11 & 16

Rev F - Removed item 8 (no longer used) from pgs 10 & 14. Updated
warranty information

Rev G - Updated technical data

Rev H - Updated part numbers for items 7, 14, & removed items 11 & 13 (per ECN 16111)

**For Warranty Information Visit:
www.balcrank.com**

Balcrank® Corporation
Weaverville, NC 28787
800-747-5300
800-763-0840 Fax
www.balcrank.com

Service Bulletin SB 1074
Rev. H 12/15