

# Balcrank®

---

## PGE-50 Pistol Grip Electronic Meters

Control Handle Models Are  
Factory Set in Quart Units

Automatic Tip  
Model #3330-044  
Rigid Extension

Semi-Auto Tip  
Model #3330-068  
Rigid Extension

3330-045  
Flex Extension

3330-069  
Flex Extension

3330-046  
Gear Oil Extension

3330-070  
Gear Oil Extension

3330-087  
Rigid Extension  
(EPDM Seals)

3330-048  
Handle Only



Thoroughly read and understand this manual before  
installing, operating or servicing this equipment.

---

Operation, Installation,  
Maintenance and Repair Guide

# GENERAL SAFETY



## Caution:

- 1) Always read and follow the fluid manufacturers's recommendations regarding the use of protective eye wear, clothing, gloves, and other personal equipment.
- 2) Never alter or modify any parts of this product; doing so may cause damage and/or personal injury.



## WARNING

Always use the following Pressure Relief Procedure whenever shutting off, cleaning, or in any way checking or servicing the control handle:

- 1) Disconnect compressed air line or turn off power supply at the fluid pump.
- 2) Point the control handle outlet into a waste container and open trigger to relieve pressure.
- 3) Open any bleed-type supply air valves and fluid drain valves in the system.
- 4) Leave the drain valves open until you are ready to re-pressurize the system.



## IMPORTANT

Read these safety warnings and instructions in this manual completely, before installation and start up of the control handle. It is the responsibility of the purchaser

to retain this manual for reference. Failure to comply with the recommendations stated in this manual will damage the control handle and void factory warranty.



## WARNING

Do not place your hand or fingers over the dispensing nozzle and/or aim the nozzle at a person at any time. Personal injury may result.



## WARNING

**DANGER:** Not for use with fluids that have a flash point below 100°F ( 38°C, examples: gasoline, alcohol). Sparking could result in an explosion which could result in death.



## WARNING

Airborne particles and loud noise hazards.

Wear ear and eye protection.

## GENERAL

This electronic lube meter is designed specifically to dispense motor oils (S.A.E. 80-240), automatic transmission fluid, and antifreeze (Ethylene Glycol) solution. Perfect balance, lightweight, ruggedness, and comfortable grip make it the best choice for overhead reel systems.

The electronic register module contains a microprocessor board powered by Lithium battery with an expected life of 3 to 5 years, depending on use. It can be programmed to dispense in pints, quarts, liters, or gallons and will totalize in liters or gallons. A calibration factor and unit of measure are programmed during factory test. Unlike mechanical meters, these units can be electronically recalibrated in the field when necessary. A 5-digit liquid crystal display, accurate to the second decimal place, shows the exact amount of fluid dispensed.

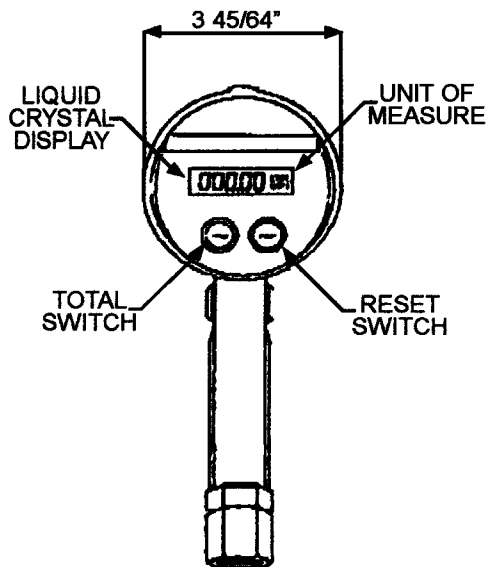

## OPERATION

As fluid passes through the metering chamber by entering the inlet port, it displaces the piston and exits through the outlet port. Each oscillation of the piston displaces a given volume of fluid. Controlled clearances between the piston and chamber wall insure minimum leakage. As the piston oscillates, its center hub rotates a magnet which activates the microprocessor.

Depressing the RESET button before each use resets the totalizer to zero. Squeezing the trigger handle dispenses the fluid.

The total amount of fluid dispensed from inventory can be checked periodically by depressing the TOTAL button. If the units dispensed are pints, quarts, or gallons, the totalizer will read in gallons. If the units dispensed are liters, the totalizer will read in liters.

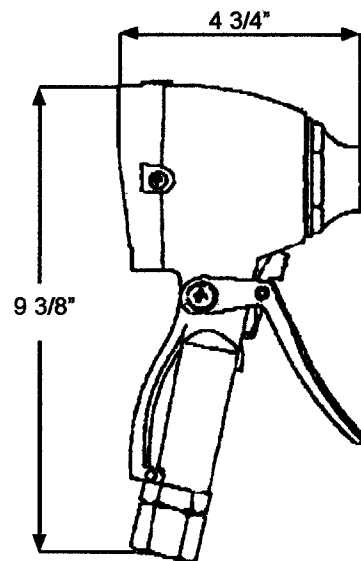

## SPECIFICATIONS:

	English	Metric
Maximum Flow*	4 GPM	15 liters/minute
Minimum Flow*	0.25 GPM	0.95 liters/minute
Operating Pressure (Maximum)	1500 PSI	100 bar
Operating Pressure (Minimum)	5 PSI	.35 bar
Operating Temperature (Maximum)	110° F	45° C
Operating Temperature (Minimum)	-10° F	-20° C
Accuracy (Non-approved Version)	± 0.5%	± 0.5%
Weight	3 lbs	1.36 Kg.
5 Digit LCD Display, 5/16" High	Pints-Quarts-Gallons	Liters
Inlet and Outlet Connections	1/2" NPTF	

\* Tested with Mobil DTE-25 motor oil at ambient temperature. Min,-Max. flow rates will vary with fluid viscosity

## PROGRAMMING SWITCH

Located on underside of module. Must be depressed for 5 seconds and released to activate the programming procedure.

## TOTAL BUTTON

- a) When depressed alone, it will display total gallons or liters used from inventory.
- b) When depressed in the programming mode, it will allow you to select any item to be changed.

## RESET BUTTON

- a) When depressed momentarily, it will clear the display
- b) When depressed in the programming mode, it will change any flashing object on the display.

## TO CHANGE UNITS OF MEASURE

- a) Remove 3 screws (2) holding electronic register module (1) to meter body.
- b) Depress the PROGRAMMING switch on bottom of module for 5 seconds and release to activate the programming procedure. A unit of measure symbol will flash.
- c) Toggle RESET button until desired unit of measure symbol appears.
- d) Again depress the programming switch on bottom of module for 5 seconds and release to end the programming procedure. This operation will lock in the selected program and blank the display.

NOTE: Changing any unit of measure will reset the totalizer to zero.

## TO RECALIBRATE

EXAMPLE: Meter delivers 4.2 quarts. Display only shows 4.0 quarts dispensed.  $4.2 \text{ (qty delivered)} \div 4.0 \text{ (qty displayed)} = 1.05 \text{ (error factor)}$ .

NOTE: Original meter correction factor is written on the top of meter housing when factory calibrated. It may have been revised after field installation. Use correction factor shown on display.

- a) Display existing meter correction factor by depressing and holding both the TOTAL and RESET buttons. (EXAMPLE: 3.4621. Make note of this number)
- b) Calculate a new meter correction factor:  $3.4621 \text{ (existing meter correction factor)} \times 1.05 \text{ (calculated error factor)} = 3.652 \text{ (new meter correction factor)}$ .

- c) Remove 3 screws holding register module to meter.
- d) Depress the PROGRAMMING switch on bottom of module for 5 seconds and release to activate the programming procedure.
- e) Display will show existing meter correction factor and programmed unit of measure symbol will be flashing.
- f) Toggle TOTAL button until left most correction factor digit that you wish to change begins to flash.
- g) Toggle RESET button until desired digit (3) appears.
- h) Toggle TOTAL button until the next digit you wish to change begins to flash.
- i) Toggle RESET button until desired digit (6) appears.
- j) Toggle TOTAL button until the next digit you wish to change begins to flash.
- k) Toggle RESET button until desired digit (3) appears.
- l) Toggle TOTAL button until the next digit you wish to change begins to flash.
- m) Toggle RESET button until desired digit (5) appears.
- n) Toggle TOTAL button until the next digit you wish to change begins to flash.
- o) Toggle RESET button until desired digit (2) appears.
- p) Again depress the PROGRAMMING switch for 5 seconds and release to end the programming procedure. This operation will lock in the selected program and blank the display. Reinstall the register to the lube meter.

NOTE: After programming, display will be blank. Depress RESET or TOTAL button to reactivate the display.

## Battery Replacement

After replacing battery, press "Battery Reset" button on circuit board prior to re-programming.



### IMPORTANT

If there are line dashes on the meter face then the "Battery Reset" button on the circuit board has not be pressed.

# TROUBLESHOOTING GUIDE

TROUBLE	CAUSE	REMEDY
No fluid passing through the meter	A. Blocked strainer B. Dirt particles jamming the rotors C. Damaged plunger seal	A. Clean or replace strainer (item 12) B. Dismantle meter assembly and clean C. Replace damaged plunger seal ( item 10)
The meter is not registering fluid output	A. Dead Battery B. No signal from the magnets C. Damaged Digital Module	A. Replace battery B. Check magnets C. Replace Digital Module (item 1)
Constant oil leak from the tip Intermittent drip from the tip	Damaged plunger seal Dirt in the tip  Tip not closed (semi-auto tip)	Replace plunger seal (check for damage) Remove the tip and blow out any dirt particles, replace if necessary Tip must be manually closed
Oil leak from the lever assembly area	Damaged quad-rings	Replace damaged quad-rings (item 7)
Low flow rate	Blocked strainer	Replace strainer (item 12)
Oil leaking from the swivel inlet	Damaged o-ring or swivel	Replace o-ring or swivel (item 13)
Line dashes on meter face	"Battery Reset" button not pressed after battery changed.	Press the "Battery Reset" Button on circuit board.

ITEM	EXTENSION		DESCRIPTION
	AUTO	SEMI-AUTO	
1	3332-024	3332-058	RIGID
2	3332-015	3332-054	FLEX
3	3332-029	3332-059	GEAR OIL



①



②



③



3332-028 - AUTOMATIC TIP

831739 - AUTOMATIC TIP WITH EPDM SEALS



3332-047 - SEMI-AUTOMATIC TIP

# PGE-50 PARTS LIST & DIAGRAM

ITEM	PART NO.	DESCRIPTION	QTY
1	829003	Digital Module	1
2		Screw	3
3	825059	Chamber & Magnet Assy.	1
4	820754	O-ring (Buna-N)	1
	831752	O-ring (EPDM)	1
5	820728	Housing Cap, NPT	1
6	820715	Cam	1
7	816263	Quad Ring (Buna-N)	2
	831753	Quad Ring (EPDM)	2
8	820714	Trigger Assy.	1
9		Screw	2
10	816239	Valve Assy.	1
	831754	Valve Assy. (EPDM)	1
11	816265	Spring	1
12	827661	Screen	1
13	825067	Swivel Adapter	1
14	828843	Battery (not shown)	1
15	811969	Swivel (prior to 9/04) (not shown)	1
	831827	Swivel (after 9/04) (not shown)	1
	832495	Swivel (after 5/08) (not shown)	1

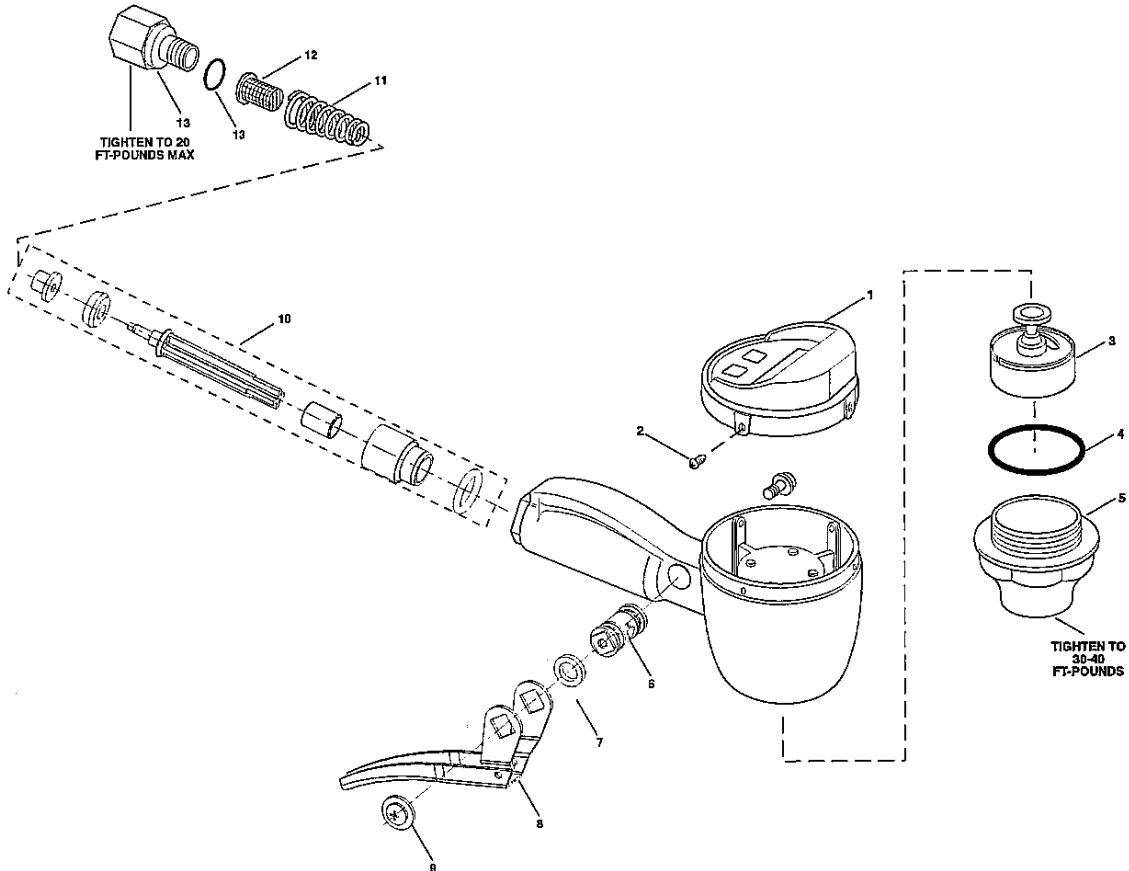



## Balcrank Lubrication Equipment Warranty Statement

All Balcrank equipment sold by authorized Balcrank distributors is warranted to their original customer to be free from defects in materials and workmanship for a period of one year from the date of sale to that customer. Selected Balcrank equipment carries warranty terms for a more extended period as defined in the Balcrank Lubrication Equipment & Accessories User Price List, wherein a "lifetime" warranty represents a warranty period of thirty years. Within the initial one-year warranty period, Balcrank will repair or replace all Balcrank equipment determined by Balcrank to have defective materials or workmanship. For equipment carrying more extended warranties, Balcrank will repair or replace the product including parts and labor during the first full year and will provide parts only for the remainder of the warranty period.

This warranty applies only to equipment installed and operated according to applicable Balcrank Service Bulletins and Installation Instructions.

Any equipment claimed to be defective must be returned, freight prepaid, to an Authorized Balcrank Service Center (ASC). Upon receiving candidate warranty equipment from a customer, ASC will: 1) diagnose to determine the warrantable condition of the equipment, 2) submit, prior to repair or replacement, a request to Balcrank for warranty authorization, then 3) in cooperation with Balcrank, proceed with repair locally or forward the equipment to Balcrank and obtain replacement. If the part(s) or equipment items are found defective upon inspection by Balcrank, they will be repaired or replaced, and then will be returned to the ASC. If Balcrank finds the claimed part(s) or equipment not to be defective, the ASC will receive written authorization from the original customer, and then repair them for a reasonable charge to the customer, which will include all applicable parts, labor, and return transportation costs.

Optionally, the customer may submit certain eligible products directly to Balcrank for warranty return by using Balcrank Lubrication Equipment Direct Service Warranty Procedure. Eligible products are defined in the Balcrank Lubrication Equipment & Accessories User Price List. Refer to the Balcrank web site [www.balcrank.com](http://www.balcrank.com) for a copy.

Any equipment returned to Balcrank must have the Warranty Service Claim number (WSC#) clearly marked on the outside of the carton. Balcrank's sole responsibility is for defects in material and workmanship, and Buyer's sole and exclusive remedy hereunder, shall be limited to repair or replacement of the defective part or equipment.

This warranty does not cover, nor shall Balcrank be liable for repair or replacement of parts or equipment resulting from general wear and tear through use, or damage or failure caused by improper installation, abuse, misapplication, abrasion, corrosion, insufficient or improper maintenance, negligence, accident, alteration, or substitution of non-Balcrank parts.

Furthermore, the Warranty for Lubrication Equipment and Accessories does not cover the following specific conditions:

- Failure or damage to equipment caused by dirt or debris in compressed air lines and fluid lines. This includes, but is not limited to, clogged inlet filters, strainers, or regulators; fluid meters; control handles; fluid tips; and valves.
- Failure of normal wear parts including but not limited to: o-rings, packings, seals and valves unless originally improperly installed by the factory.
- Products placed in applications for which their use was not intended. Examples include but are not limited to Lubricant pump being used to pump solvents, or placing equipment intended strictly for indoor use outdoors
- Damage to equipment resulting from operation above and beyond Balcrank's recommendations.
- Leaks at air and fluid fittings and connections.
- Damage caused by thermal expansion whenever adequate pressure relief was not included in the system.
- Loose suction tubes on pumps.
- Incorrect hose reel spring tension, requiring adjustment.

THERE ARE NO OTHER WARRANTIES, EXPRESSED OR IMPLIED, INCLUDING WARRANTIES OF MERCHANTABILITY OR FITNESS FOR A PARTICULAR PURPOSE. IN NO EVENT SHALL BALCRANK BE LIABLE FOR ANY SPECIAL, CONSEQUENTIAL, OR OTHER DAMAGES OF SIMILAR NATURE, INCLUDING BUT NOT LIMITED TO LOST PROFITS, LOST PRODUCTION, PROPERTY DAMAGE, PERSONAL INJURY, WHETHER SUFFERED BY BUYER OR ANY THIRD PARTY, IRRESPECTIVE OF WHETHER CLAIMS OR ACTIONS, LEGAL OR EQUITABLE, FOR SUCH DAMAGES ARE BASED UPON CONTRACTS, WARRANTY, NEGLIGENCE, STRICT LIABILITY, OR OTHERWISE. ANY CLAIM OR ACTION FOR BREACH OF WARRANTY MUST BE BROUGHT WITHIN TWO (2) YEARS FROM THE DATE OF SALE TO THE ORIGINAL CUSTOMER.

Balcrank® Corporation  
Weaverville, NC 28787  
800-747-5300  
800-763-0840 Fax  
[www.balcrank.com](http://www.balcrank.com)

Distributed by:

SERVICE BULLETIN SB3023

Rev. I 5/08  
830408