



General Safety

Thoroughly read and understand this manual before installing and/or operating the described products.

Because this pressure relief kit will be incorporated into a pressurized system, the following safety precautions should be observed:

- Check equipment regularly and repair or replace worn and damaged parts.
- Release pressures built up in the system before any service or repair is begun. See Pressure Relief Procedure.
- Never alter or modify any parts of this kit; doing so may cause damage to the equipment and/or personal injury.
- Never aim a dispensing valve at any person. Personal injury may result.
- Always read and follow fluid manufacturers' recommendations regarding proper use of protective eye wear, clothing and respirators.
- Read all limitations which apply to selection of fluids that may be pumped through this product. Do not pump a fluid which is not specified to be compatible.

Pressure Relief Kit

MODEL #3120-023
3120-024

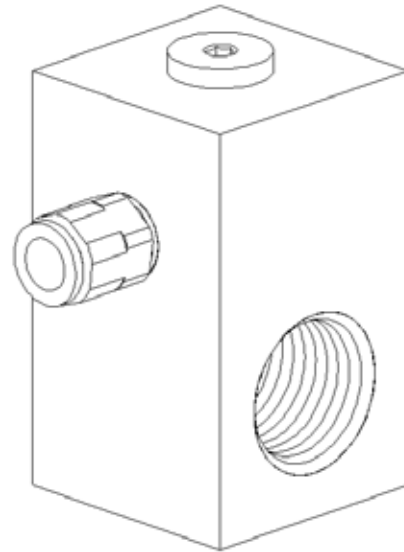

	WARNING
Pressure Relief Procedure:	
Follow this procedure whenever you shut off the pump, when checking or servicing any part of the system and when installing, cleaning or changing any part of the system.	
<ol style="list-style-type: none">1) Disconnect the air to the pump.2) Point dispensing valve away from yourself and others.3) Open dispensing valve until pressure is relieved.	

NOTE: This pressure relief kit is required on all Balcrank® supply systems. The lack of installing this kit will void all product warranties if system fails because of thermal expansion.
--

Installation

Assemble pressure relief valve to hardware provided with kit. Assemble nipple with pipe sealant to inlet of pressure relief valve and tubing to fitting provided on block. Attach other end of tubing to a certified waste container or route back to fluid supply container.

Model Number	Thread
3120-023	1/2" NPT
3120-024	1" NPT

	CAUTION
This kit protects the system from possible damage due to fluid thermal expansion. Excess fluid pressure above psi rating (see chart) is relieved; slight relief overflow is directed back to supply container.	
Model # 3120-023 & 3120-024	PSI Rating 125 psi

**For Warranty Information Visit:
www.balcrank.com**

Balcrank® Corporation
Weaverville, NC 28787

800-747-5300
800-763-0840 Fax
www.balcrank.com

Revision Log

Rev A - Release
Rev B - Removed obsolete model
numbers

Service Bulletin SB3037
Rev B 10/12