

Balcrank

FOLLOWER PLATES FOR CHASSIS PUMP

Models 4440-001

4440-002

4440-003

FOLLOWER PLATES FOR CHASSIS PUMP MODEL NUMBERS FOR ASSEMBLY OF FOLLOWER PLATES

<u>MODEL NO.</u>	<u>DESCRIPTION</u>
4440-003	Assembly for 25#, 35#, and 50# pails 810334 Guide tube 810397 Follower plate - includes O-ring 807343 806899 O-ring 826813 Collar
4440-002	Assembly for 120# drum 814349 Guide tube 810399 Follower plate - includes O-ring 807343 806899 O-ring 826813 Collar
4440-001	Assembly for 400# drum 806899 O-ring 810257 Guide tube Follower plate only assembly 826813 Collar

Thoroughly read and understand this manual before installing, operating or servicing this equipment.

**OPERATION, INSTALLATION,
MAINTENANCE AND REPAIR GUIDE**

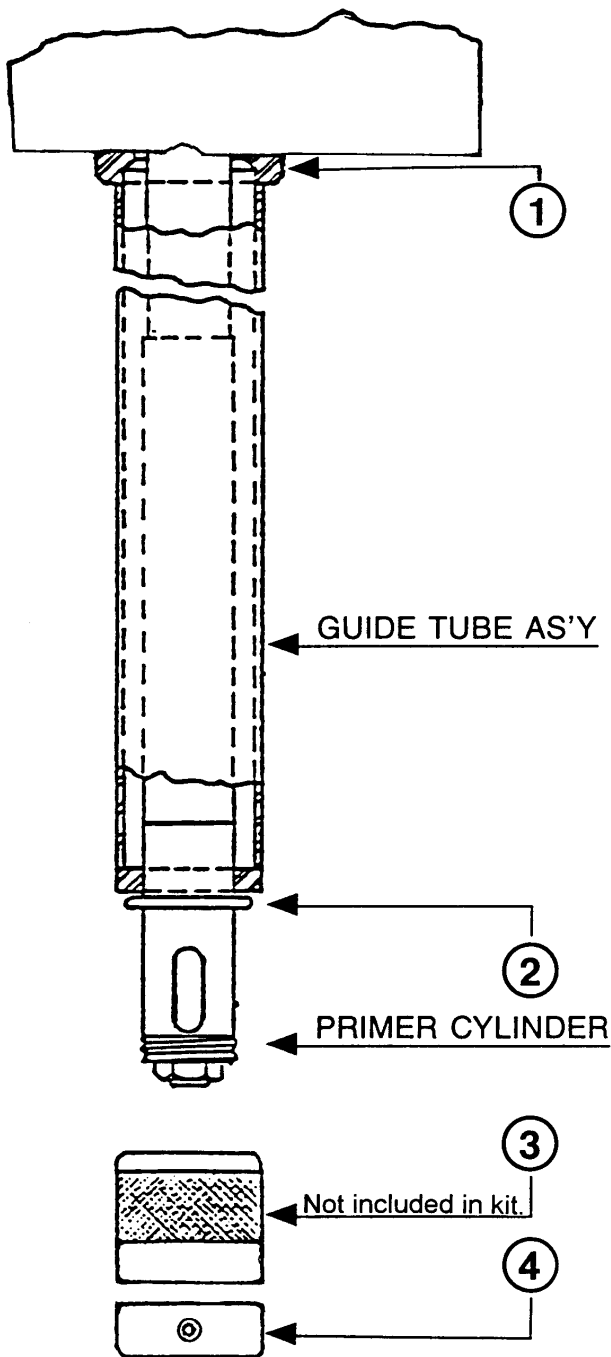

INSTALLATION INSTRUCTIONS

1. Remove screen (3) if necessary from lower end of pump tube by unscrewing with a pipe wrench, remove and discard snap ring from primer cylinder. (**CAUTION:** Grasp screen with pipe wrench on knurled portion. If wrench is used at any other point screen may become damaged.)
2. Select proper model number for assembly of follower plate. (See reverse side of this instruction sheet for model descriptions.)
3. Slide the guide tube (full open end first) over the pump tube and into recessed end of packing nut (1) at base of pump.
4. Stretch the O-ring(2) over the lower end of the primer cylinder and slide into place against the lower end of the guide tube. Replace screen or slide collar primer over cylinder until it rests against the O-ring then tighten set screws. (**CAUTION:** Do not over tighten set screw, pump damage will occur.)
5. Place follower plate into the grease drum and pack well, in order to force the air from under the plate out. Insert the pump and tube into the center hole of the follower plate and push pump down into the grease. Unit is ready for operation.

ITEM	PART NO.	DESCRIPTION
1		Guide tube
2	806899	O-ring
3		Screen assembly
4	826813	Collar

Balcrank Corporation
 Weaverville, NC 28787
 800-747-5300
 800-763-0840 Fax

Distributed by: