

Balcrank®

HP JET PUMP - ADJUSTABLE COVER & HANDLE ASSEMBLY

Models 1151-014

With 7 ft. Hose & Control Handle

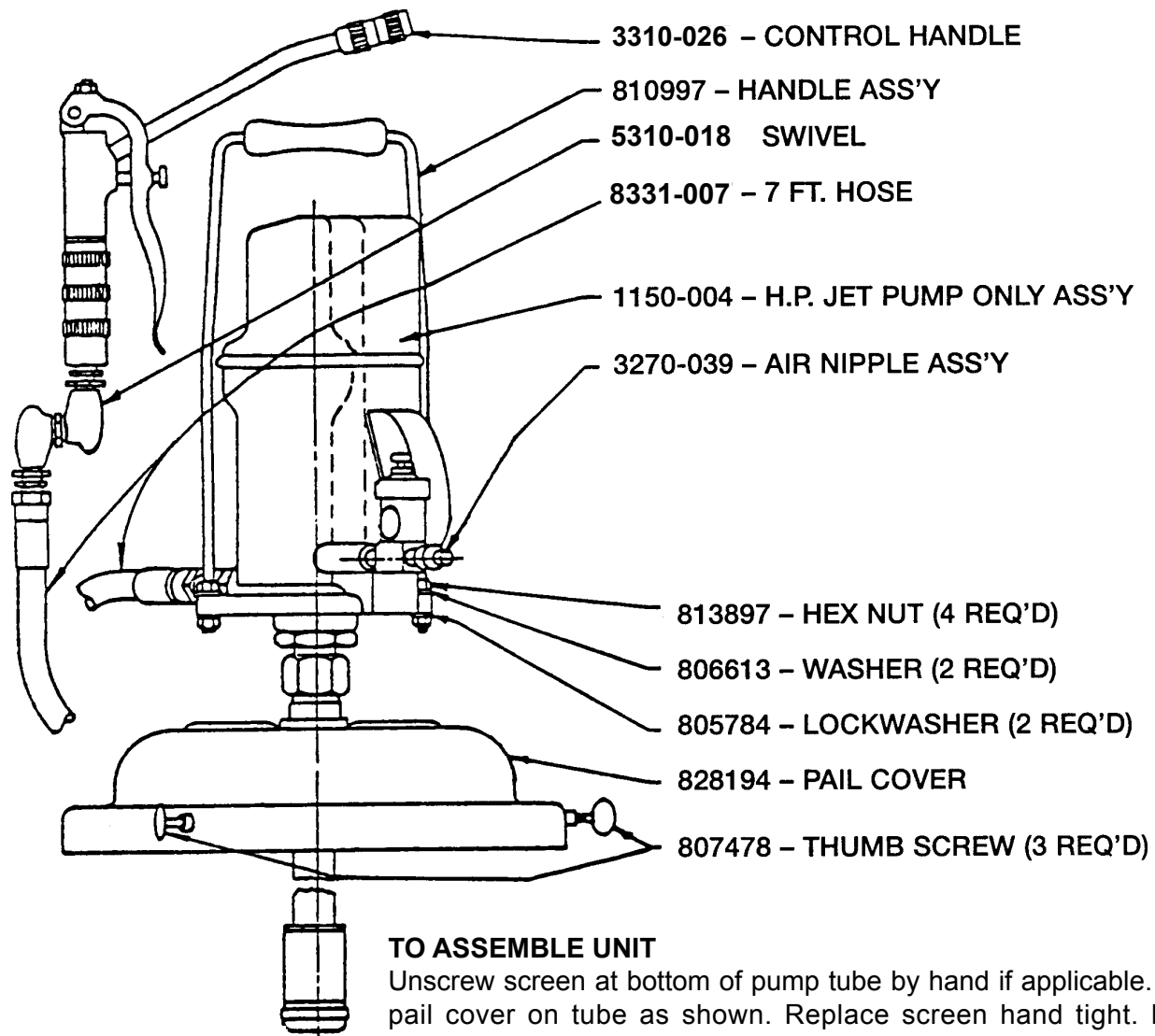

TO ASSEMBLE UNIT

Unscrew screen at bottom of pump tube by hand if applicable. Slide pail cover on tube as shown. Replace screen hand tight. Place complete unit in pail, pushing down on handle 810997, making sure pump screen is resting on bottom of pail. Tighten lock nut securely at top of pail cover, using large wrench. Thread the three (3) thumb screws 807478 into socket on side of pail cover and tighten securely by hand. Assemble hose to handle and screw complete hose and handle assembly on unit. Tighten securely with wrench.

NOTE: To adjust pump length for various sizes of pails, loosen lock nut at top of pail cover, make adjustment, tighten lock nut.

Balcrank Lubrication Equipment Warranty Statement

All Balcrank equipment sold by authorized Balcrank distributors is warranted to their original customer to be free from defects in materials and workmanship for a period of one year from the date of sale to that customer. Selected Balcrank equipment carries warranty terms for a more extended period as defined in the Balcrank Lubrication Equipment & Accessories User Price List, wherein a "lifetime" warranty represents a warranty period of thirty years. Within the initial one-year warranty period, Balcrank will repair or replace all Balcrank equipment determined by Balcrank to have defective materials or workmanship. For equipment carrying more extended warranties, Balcrank will repair or replace the product including parts and labor during the first full year and will provide parts only for the remainder of the warranty period.

This warranty applies only to equipment installed and operated according to applicable Balcrank Service Bulletins and Installation Instructions.

Any equipment claimed to be defective must be returned, freight prepaid, to an Authorized Balcrank Service Center (ASC). Upon receiving candidate warranty equipment from a customer, ASC will: 1) diagnose to determine the warrantable condition of the equipment, 2) submit, prior to repair or replacement, a request to Balcrank for warranty authorization, then 3) in cooperation with Balcrank, proceed with repair locally or forward the equipment to Balcrank and obtain replacement. If the part(s) or equipment items are found defective upon inspection by Balcrank, they will be repaired or replaced, and then will be returned to the ASC. If Balcrank finds the claimed part(s) or equipment not to be defective, the ASC will receive written authorization from the original customer, and then repair them for a reasonable charge to the customer, which will include all applicable parts, labor, and return transportation costs.

Optionally, the customer may submit certain eligible products directly to Balcrank for warranty return by using Balcrank Lubrication Equipment Direct Service Warranty Procedure. Eligible products are defined in the Balcrank Lubrication Equipment & Accessories User Price List. Refer to the Balcrank web site www.balcrank.com for a copy.

Any equipment returned to Balcrank must have the Warranty Service Claim number (WSC#) clearly marked on the outside of the carton. Balcrank's sole responsibility is for defects in material and workmanship, and Buyer's sole and exclusive remedy hereunder, shall be limited to repair or replacement of the defective part or equipment.

This warranty does not cover, nor shall Balcrank be liable for repair or replacement of parts or equipment resulting from general wear and tear through use, or damage or failure caused by improper installation, abuse, misapplication, abrasion, corrosion, insufficient or improper maintenance, negligence, accident, alteration, or substitution of non-Balcrank parts.

Furthermore, the Warranty for Lubrication Equipment and Accessories does not cover the following specific conditions:

- Failure or damage to equipment caused by dirt or debris in compressed air lines and fluid lines. This includes, but is not limited to, clogged inlet filters, strainers, or regulators; fluid meters; control handles; fluid tips; and valves.
- Failure of normal wear parts including but not limited to: o-rings, packings, seals and valves unless originally improperly installed by the factory.
- Products placed in applications for which their use was not intended. Examples include but are not limited to Lubricant pump being used to pump solvents, or placing equipment intended strictly for indoor use outdoors
- Damage to equipment resulting from operation above and beyond Balcrank's recommendations.
- Leaks at air and fluid fittings and connections.
- Damage caused by thermal expansion whenever adequate pressure relief was not included in the system.
- Loose suction tubes on pumps.
- Incorrect hose reel spring tension, requiring adjustment.

THERE ARE NO OTHER WARRANTIES, EXPRESSED OR IMPLIED, INCLUDING WARRANTIES OF MERCHANTABILITY OR FITNESS FOR A PARTICULAR PURPOSE. IN NO EVENT SHALL BALCRANK BE LIABLE FOR ANY SPECIAL, CONSEQUENTIAL, OR OTHER DAMAGES OF SIMILAR NATURE, INCLUDING BUT NOT LIMITED TO LOST PROFITS, LOST PRODUCTION, PROPERTY DAMAGE, PERSONAL INJURY, WHETHER SUFFERED BY BUYER OR ANY THIRD PARTY, IRRESPECTIVE OF WHETHER CLAIMS OR ACTIONS, LEGAL OR EQUITABLE, FOR SUCH DAMAGES ARE BASED UPON CONTRACTS, WARRANTY, NEGLIGENCE, STRICT LIABILITY, OR OTHERWISE. ANY CLAIM OR ACTION FOR BREACH OF WARRANTY MUST BE BROUGHT WITHIN TWO (2) YEARS FROM THE DATE OF SALE TO THE ORIGINAL CUSTOMER.

Balcrank® Corporation
Weaverville, NC 28787
800-747-5300
800-763-0840 Fax
www.balcrank.com

Distributed by:

SERVICE BULLETIN SB4019
Rev. B 5/08
822005