



# General Safety

Thoroughly read and understand this manual before installing, operating or servicing the described products.



## IMPORTANT

Because this pump can be incorporated into a pressurized systems, the following safety precautions should be observed.

Check equipment regularly and repair or replace worn and damaged parts.

Never alter or modify any parts of this pump, doing so may cause damage to pump and/or personal injury.

Under no circumstances should the dispensing valve be aimed at any person at any time. Personal injury may result.

Release pressures built up in the system before any service or repair is begun. See the pressure relief procedure below.

Do not operate this pump above 150 PSI (10.3 BAR) air inlet pressure or 200 cycles per minute.

Always read and follow the fluid manufacturer's recommendations regarding the use of protective eyewear, clothing and respirators.



## WARNING

Pressure Relief Procedure:

Follow this procedure whenever you shut off the pump, when checking or servicing any part of the system and when installing, cleaning or changing any part of the system.

- 1) Disconnect the air to the pump.
- 2) Point dispensing valve away from yourself and others.
- 3) Open dispensing valve until pressure is relieved.



## WARNING

Use 3241-002 Pump Over-Run control valve on pump air inlet for remotely operated pumps. Failure to use this valve can cause pump to cycle quickly when barrel is empty of grease. **THIS WILL DAMAGE THE PUMP** and may void factory warranty.



## WARNING

**WARNING:** The Jet Power™ 50:1 grease pump develops up to 7500 psi (517 Bar) maximum working pressure at 150 psi (10.3 Bar) maximum inlet air pressure and stall conditions. Be sure that any components or accessories used in the system are rated to withstand this pressure. To determine fluid output pressure at stall conditions, multiply the ratio of the pump by the air pressure being used.

**EXAMPLE:** 50:1 Pump Ratio x 100 psi air pressure = 5000 psi fluid pressure at stall.



## WARNING

**THIS PUMP CONTAINS ALUMINUM AND ZINC PARTS. DO NOT** use 1-1-1

Trichloroethane, methylene chloride or other halogenated hydrocarbon solvents or fluids containing such solvents in this pump. Use of these solvents/fluids may result in a violent chemical reaction, causing serious bodily injury, property damage or death. All fluids used in this pump must be chemically compatible with the wetted parts materials shown on page two (2) of this manual. Consult your chemical supplier to ensure compatibility.



## WARNING

**DANGER:** Not for use with fluids that have a flash point below 100°F (38°C). Examples: gasoline, alcohol. Sparking could result in an explosion which could result in death.



## WARNING

In the presence of explosive vapors, take action to prevent static sparking. Failure to ground the pump, piping, valves, containers, or other miscellaneous equipment can result in fire or explosion. A green grounding lug is provided on the pump.

## PRODUCT DESCRIPTION

The Jet Power™ Pump is a Balcrank® time tested, reliable pump with a 50:1 ratio and a large diameter air piston rated for 150 psi continuous duty. The Jet Power™ Pump is suitable for grease distribution to multiple dispensing points or for dispensing distances up to 300 feet.

The Jet Power™ Pump air motor features precision cast aluminum allot parts, it has a simple durable construction with all internal parts lubricated ad the factory with a life tested synthetic grease (Balcrank Part # 826733). This grease coats all internal parts and repels air line moisture to inhibit corrosion.

The Jet Power™ pumping assembly features steel pump rods, tubes, and high quality grease seals and packings and a shovel type primer piston all incorporated in a precision built assembly.

## TECHNICAL DATA

Pressure Ratio.....	50:1
Air Motor Bore .....	3.38" (effective diameter 2.62")
Stroke .....	2.12"
Operating Air Pressure Range.....	40-150 PSI (2.7-10.3 BAR)
Air Consumption (@100 psi) .....	50 CFM <sup>1</sup>
Air Inlet Port Size.....	1/4"
Material Outlet Port.....	1/4"
Wetted Parts.....	Steel, Buna-N

1. Air consumption varies with pump speed.

## DELIVERY PER MINUTE, LBS

LUBRICANT	@75° F	@40° F
Light body grease .....	3.0 .....	2.5
Viscous grease .....	2.5 .....	1.8
Fibrous grease .....	1.5 .....	1.2

## INSTALLATION

Remove pump from carton and attach to cover, bung fitting or other mounting.

Blow out any foreign material from the air supply line before connecting to pump. An air line filter/regulator is recommended for all applications; wet and dirty air will shorten the life of the pump. For severe duty applications, an air line lubricator is recommended for better performance and longer pump life. Use 10 to 20 weight lubricant and set for 1 drop every 2 minutes of use. If using a follower plate assembly, see Service Bulletin SB 4010.

Be sure air supply is off before connecting to pump. Gradually open air regulator valve until pump begins to cycle. The pump should prime within 1 to 3 minutes. Pump a small amount of fluid at low air pressure to remove trapped air and foreign materials from lines. Discard this waste material.

Consult with local and state authorities to determine proper disposal of waste material

After the pump system is fully primed, open air supply valve until desired flow and/or pressure is obtained. Always use the lowest pressure needed to obtain the desired results. This reduces pump wear.

## TROUBLESHOOTING

Read all instructions carefully before servicing. If pump does not operate properly, check the following points carefully (before making any adjustments or repairs) to determine which part of the installation is at fault.

- I. (a) Is pump getting an adequate supply of air? Connect air gauge to coupler. Pumps should develop grease pressure approximately 50 times the air pressure used. Most practical grease pressure is developed by 150 pounds of air pressure.  
(b) Check air coupler to pump to make sure it is connected securely.
- II. Check grease drum to make sure pump tube is submerged in lubricant. Change drum if necessary.

- III. Check grease line for leaks in hose, swivels, connectors, control handle, and pipe line. Pump will operate continuously to replace leaking grease.

After preceding points have been checked,, proceed as follows with the case or cases which appear to meet your situation.

CASE 1: Pump not operating at all (air valve (38) not tripping over) or air blowing constantly from air valve.

- A. Toggle of air valve assembly may be rubbing against tripper rod (13) and the friction is preventing it from tripping. In some cases, it may only be rubbing a little and when the pump is running free, the toggle is moving fast enough to overcome friction, but when the pump builds up pressure and slows down, the toggle will stick. Remove air valve by unscrewing two cover screws (47) and six clamp screws (2). Pry the toggle apart slightly with screwdriver. Replace.
- B. The six screws (2) holding the air valve assembly to the casting may be loose; tighten them securely. In most cases, the air valve assembly will operate if these screws are loose, but it will be sluggish and air will probably leak. The same thing will happen if gasket (44) between the air valve assembly and the pump casting is damaged or worn.
- C. If air valve assembly (38) still will not operate, it will be necessary to replace it. Replacement is very simple and the cost is reasonable. Parts for the air valve are not sold individually.

CASE 2: Hose pulsating with absence of grease under pressure. This is an indication the primer valve (16) or ball (4) are not seating properly. Check ball outlet assembly at point of hose attachment as ball (33) may be seating properly.

- A. To clean ball seat and primer valve, proceed as follows: Unscrew screen (4430-001) at lower end of tube with pipe wrench, if applicable, grasping same at extreme lower end. Loosen primer cylinder (19) with pipe

wrench but do not remove. Line up slots in primer cylinder with small hole (3/16") in primer rod (17). Insert 5/32" steel rod or punch through slot of primer cylinder and hole in primer rod.

- B. Unscrew nut (5) and pull of primer piston (18). Remove steel rod or punch and unscrew primer cylinder (19) previously loosened. Unscrew grease cylinder (37) and slide of rod. Primer valve is inside this cylinder. Push out with smaall rod or screwdriver. Inspect for dirt, clean thoroughly.
- C. Unscrew primer rod (17). Pull off brass bushing (52) and u-cup seal (53) in order. Inspect packings for wear, replace if necessary. Unscrew piston adapter (51) and tap out spring (22) and ball (4). Clean ball and piston adapter thoroughly. Reseat ball, using soft metal rod and tapping lightly with small hammer.

To clean outlet ball check, unscrew adapter (50) and remove ball retainer (11) and ball (33). Clean ball and seat thoroughly and reseat as outlined above.

Reassemble and pump is ready for use, no priming necessary.

CASE 3: Air escaping around air piston guide (45). This is an indication that the two o-rings (10) or the o-ring (42) are damaged or worn.

- A. Remove the four screws (48) which attach the air piston guide (45) to the air cylinder body (31) and lift off air piston guide. Unscrew two bolts (30) which secure tripper rod arm (6) to the air piston (12). Lift off tripper rod arm and replace bolts (30). Using a screw driver or metal rod across air piston and between hiads of bolts, unscrew air piston (12) from pump rod (34). Pull air piston and retainer ring (14) from air cylinder body (31). Slide retainer ring (14) off air piston and inspect upper and lower o-rings (10) and o-ring (42) for wear. Replace if necessary.

Reassemble and pump is ready for use.

CASE 4: Grease escaping through air valve and port in base of pump or air blowing through port in base of pump into grease drum. This is an indication that the packings in the lower air cylinder body are damaged or worn.

- A. Remove primer tube, rod, etc. as outlined in CASE 2.
- B. Unscrew packing nut (25), Unscrew pump rod and pull from air cylinder body. The pump tube adapter (5), hydraulic u-packing (49), rubber backup washer (35), plastic packing washer (36), packing spacer (27), spring (28), wiper casing (29), wiper (7) Stop (26), o-ring (8) and gasket (24) should pull out with rod. If not, pull out by using a wire with a small hook on it.
- C. Inspect for wear and replace damaged or worn parts. Reassemble and pump is ready for use.

NOTE: Outlet body (32) screws into pump tube adapter (15) and must be replaced prior to tightening packing nut (25) and pump tube as outlet must be lined up with opening in air cylinder body.

If you cannot distinguish your difficulty or if after trying the remedial procedure without material success, call your nearest Balcrank Authorized Service Center.

# PARTS LIST

Line	Part #	Description	Qty
1	806015	Pipe Plug	1
2	806132	Screw	6
3	806265	Lock Washer	6
4	806289	Ball - 7/32" diameter * **	1
5	806467	Hex Nut	1
6	806512	Tripper Rod Arm	1
7	806812	Wiper * **	1
8	806895	O-ring * **	1
9	806899	Seal Ring (REF)	1
10	806906	O-ring	3
11	807162	Ball Stop	1
12	807387	Air Piston	1
13	807388	Tripper Rod	1
14	807390	Retainer Ring	1
15	807394	Pump Tube Adapter	1
16	807406	Primer Valve	1
17	807408	Primer Rod	1
18	807410	Primer Piston	1
19	807412	Primer Cylinder	1
20	807415	Screen - 30 mesh ~	1
21	807448	Clamp Nut	1
22	807454	Valve Spring * **	1
23	807465	Square Nut	1
24	807482	Gasket * **	1
25	807483	Packing Nut	1
26	807488	Packing Stop	1

27	807490	Packing Spacer	1
28	807515	Packing Spring	1
29	807517	Wiper Casing	1
30	807532	Screw, Filister Head	2
31	807537	Air Cylinder Body	1
32	807545	Outlet Body	1
33	807549	Ball - 11/32" diameter	1
34	808327	Upper Rod	1
35	808444	Rubber Back-up Washer * **	1
36	808488	Teflon Packing Washer * **	1
37	808590	High Pressure Cylinder **	1
38	810071	Air Valve Assembly	1
39	813378	Top Collar ~	1
40	813380	Screen Support ~	1
41	813382	Bottom Collar ~	1
42	814075	O-ring * **	1
43	814349	Guide Tube (REF)	1
44	821957	Gasket	1
45	830006	Cap	1
46	823185	Valve Cover	1
47	823866	Screw, Round Head	2
48	823867	Screw	4
49	826782	Packing 8 88	1
50	827698	Retainer	1
51	828469	Piston Adapter * **	1
52	828528	Brass Bushing * **	1
53	829154	U-packing * **	1

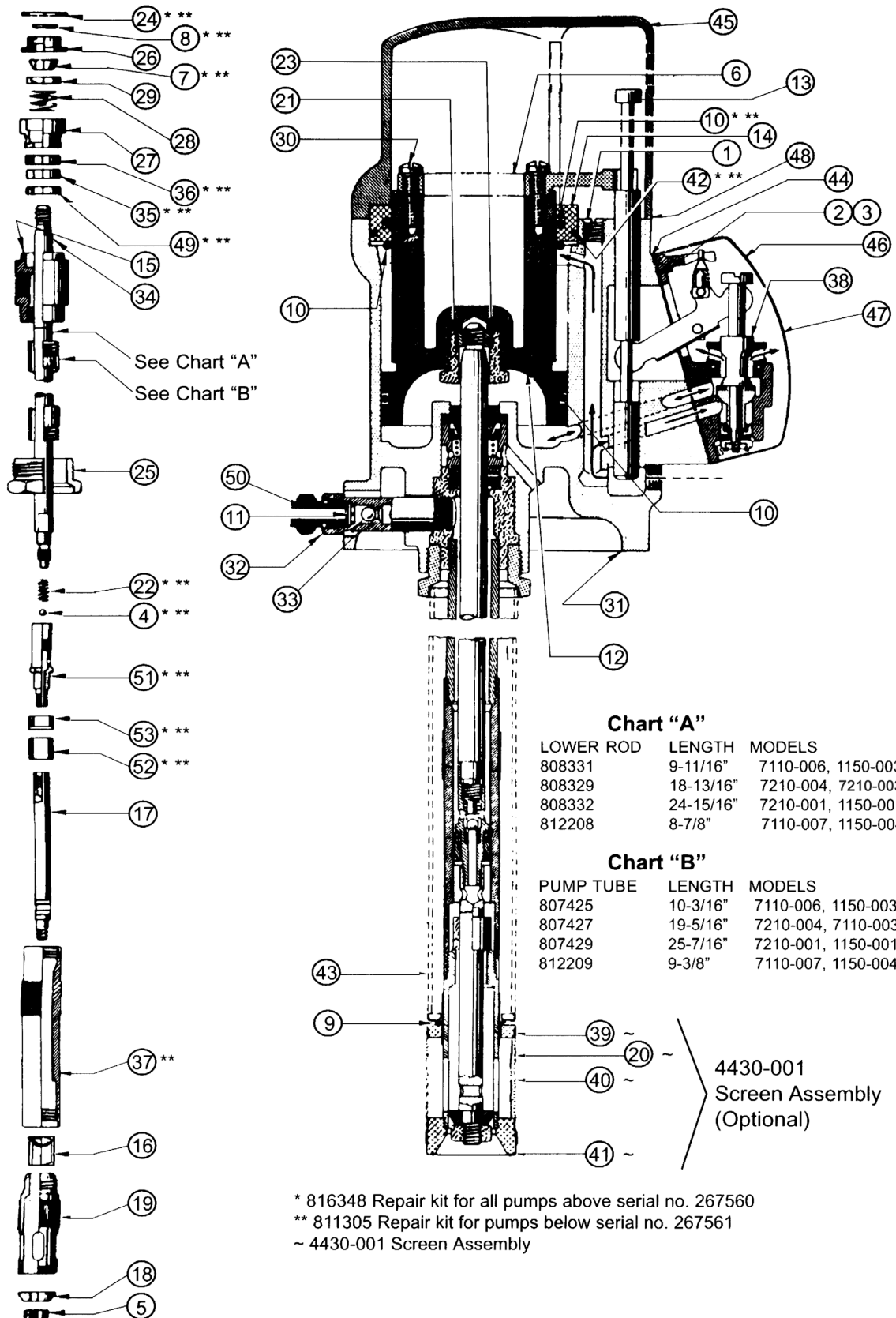

**Chart "A"**

LOWER ROD	LENGTH	MODELS
808331	9-11/16"	7110-006, 1150-003
808329	18-13/16"	7210-004, 7210-003, 1150-005
808332	24-15/16"	7210-001, 1150-001
812208	8-7/8"	7110-007, 1150-004

**Chart "B"**

PUMP TUBE	LENGTH	MODELS
807425	10-3/16"	7110-006, 1150-003
807427	19-5/16"	7210-004, 7110-003, 1150-005
807429	25-7/16"	7210-001, 1150-001
812209	9-3/8"	7110-007, 1150-004

4430-001  
Screen Assembly  
(Optional)

\* 816348 Repair kit for all pumps above serial no. 267560  
 \*\* 811305 Repair kit for pumps below serial no. 267561  
 ~ 4430-001 Screen Assembly

