



Center Flo Pump - CF30

- Model 1120-024Aluminum
- Model 1120-026Polypropylene
- Model 1120-031Diesel Exhaust Fluid (DEF)



1120-024



1120-026 / 1120-031

Thoroughly read and understand this manual before installing, operating or servicing this equipment.

**OPERATION, INSTALLATION,
MAINTENANCE AND REPAIR GUIDE**

GENERAL SAFETY REQUIREMENTS

NOTE: THOROUGHLY READ AND UNDERSTAND THIS MANUAL BEFORE INSTALLING, OPERATING OR SERVICING THIS EQUIPMENT.

	<p>! IMPORTANT</p> <p>Because this pump can be incorporated into pressurized systems, the following safety precautions should be observed.</p>
<p>Check equipment regularly and repair or replace worn and damaged parts.</p> <p>Never alter or modify any parts of this pump, doing so may cause damage to pump and/or personal injury.</p> <p>Under no circumstances should the dispensing valve be aimed at any person at any time. Personal injury may result.</p> <p>Release pressures built up in the system before any service or repair is begun. See the pressure relief procedure below.</p> <p>Do not operate this pump above 100 PSI (6.89 BAR) air inlet pressure .</p> <p>Always read and follow the fluid manufacturer's recommendations regarding the use of protective eyewear, clothing and respirators.</p>	

	<p>! WARNING</p>
<p>PRESSURE RELIEF PROCEDURE: Follow this procedure whenever you shut off the pump, when checking or servicing any part of the system and when installing, cleaning or changing any part of the system.</p> <ol style="list-style-type: none"> 1) Disconnect the air to the pump. 2) Point dispensing valve away from yourself and others. 3) Open dispensing valve until pressure is relieved. 	

	<p>! WARNING</p>
<p>Pump develops 100 PSI (6.89 BAR) maximum working pressure at 100 PSI (6.89 BAR) maximum inlet air pressure. Be sure that any components or accessories used in the system are rated to withstand this pressure. To determine fluid outlet pressure, multiply the ratio of the pump by the air pressure being used.</p> <p>EX: 1.1 (1:1 ratio) x 100 PSI = 100 PSI fluid pressure. 1.1 (1:1 ratio) x 6.89 BAR = 6.89 BAR fluid pressure.</p>	

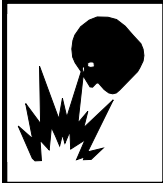
	<p>! WARNING</p>
<p>DANGER: Not for use with fluids that have a flash point below 100°F (38°C). Examples: gasoline, alcohol.</p> <p>Sparking could result in an explosion which could result in death.</p>	

	<p>! WARNING</p>
<p>In the presence of explosive vapors, take action to prevent static sparking. Failure to ground the pump, piping, valves, containers, or other miscellaneous equipment can result in fire or explosion.</p>	

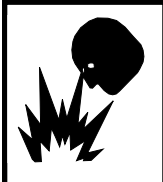
	<p>! WARNING</p>
<p>Do NOT use with solvents or other explosive fluids.</p>	

<p>! CAUTION</p>	
<p>Pressure variations can cause vibration in piping systems. Connect the pump to the piping system using flexible hoses. Ensure pipes and fittings are properly secured to their supports. Do not use the pump as part of the support structure of the piping system.</p>	

TABLE OF CONTENTS

Cover.....	1
General Safety Information.....	2
Technical Data.....	3
Dimensional Data.....	4
Installation/Operation.....	5 - 8
Troubleshooting.....	9 & 10
Repair Kits.....	10
Parts Diagram.....	11
Parts Listing.....	12
Maintenance & Repair.....	13 - 15

TECHNICAL DATA

Pressure Ratio.....	1:1
Air Pressure Operating Range.....	45-100 psi
Maximum Fluid Working Pressure.....	100 psi
Delivery per minute*.....	28 gpm
Solid in suspension max size.....	0.16 in.
Air Inlet Port Size.....	3/8" NPSM (F)
Fluid Inlet Port Size.....	1" NPTF
Fluid Outlet Port Size.....	1" NPTF
Fluid Inlet Port Size (1120-031).....	1" BSPP
Fluid Outlet Port Size (1120-031).....	1" BSPP
Max Suction Head (Dry).....	15'
Max Suction Head (Wet).....	23'

PRODUCT DESCRIPTION

The models 1120-024 & 1120-026 are designed for use in fluid transfer, evacuation and distribution system applications of lubricants, waste oil, transmission fluid, anti-freeze and water. The model 1120-031 is designed for use in fluid transfer, evacuation and distribution system applications of Diesel Exhaust Fluid (DEF).

Wetted Parts:

1120-024.....	Aluminum, Hytrel, Acetal, Teflon®, NBR, Stainless Steel
1120-026 & 1120-031.....	Polypropylene, Hytrel, PTFE, Viton®, Stainless Steel

Weight:

1120-024.....	15.9 lbs.
1120-026 & 1120-031.....	14.3 lbs.

Noise Level.....80db

* free flow @ 100 psi air input

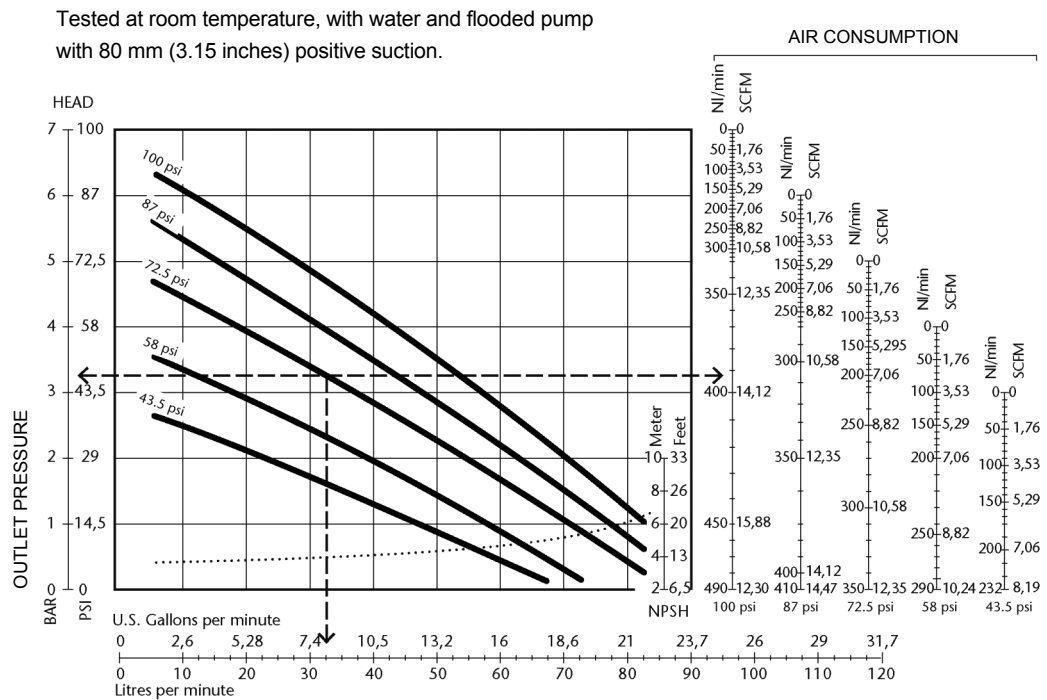

DIMENSIONS (inches)

A	B	C	D	E	F
8.5	7.44	8.93	6.88	6.06	0.35
G	H	I	J	K	L
7.24	8.26	3.72	1	8.26	3/8

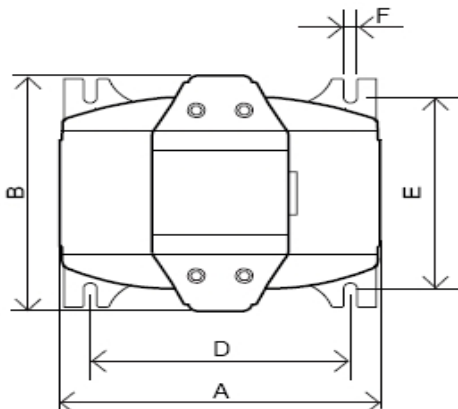
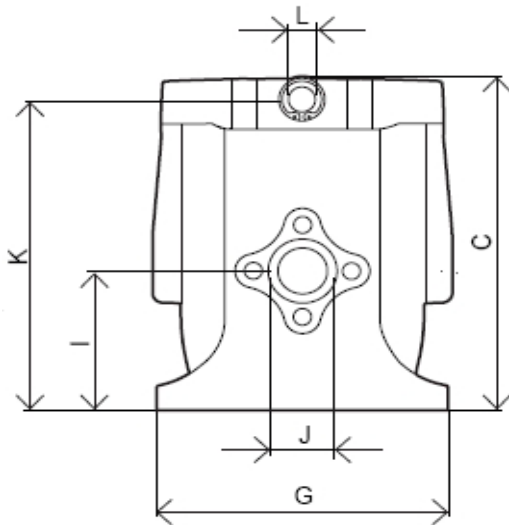
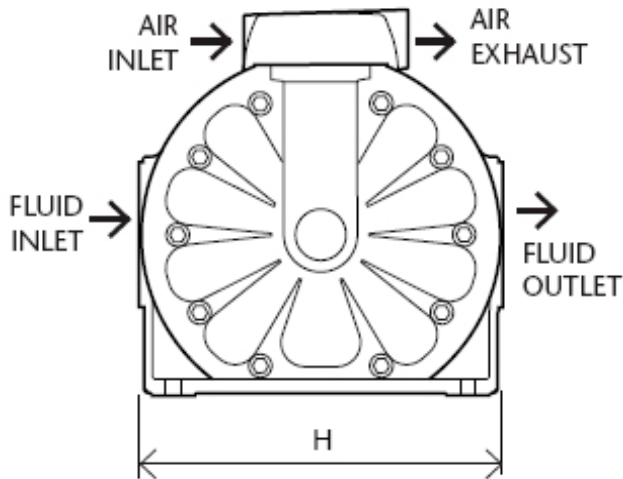

SAFETY

- The pump is intended for non-corrosive and petroleum based liquids. It may NOT be used for other purposes or for pumping gasoline, or other explosive liquids.
- Check that all components used are suitable for the operating pressure of the system.
- Do not use higher pressure than required for the satisfactory functioning of the system.
- Before work is undertaken on the pump the compressed air should be disconnected from the pump and the whole system should then be depressurized.
- Check all components thoroughly for damage and leakage.
- Ensure that the compressed air is disconnected from the pump and the system is depressurized when system is not in use (i.e. overnight or during longer shut down periods) as there is always a risk of hoses bursting or pipework leaking etc.

GENERAL

Air operated double diaphragm pumps are air-powered, reciprocating positive displacement pumps with two pumping chambers. Two diaphragms, centrally located in the chambers, separate the compressed air (dry side) from the fluid being pumped (wet side). A shaft transmits the reciprocating motion of one diaphragm to the other. An air valve alternately distributes the air from one chamber to the other; thus a reciprocating movement of the diaphragms is created. With each stroke, fluid is discharged by one of the diaphragms whilst the opposite diaphragm suctions new fluid into the expanding chamber. Check valves, two on the discharge side and two on the suction side, control and direct the fluid flow.



WARNING

The maximum permitted air pressure is 100 psi, do not exceed this limit. Service: Before any servicework is carried out the compressed air must be turned off to the pump or the air coupling disconnected. The fluid outlet must be depressurized completely. Follow pressure relief procedure.

TYPICAL INSTALLATIONS

Flooded:

The pumping system was designed with positive pressure at the inlet. This is the best possible installation when you need to evacuate fluid from a drum or tank, or when working with viscous fluids. Not recommended for hazardous fluids.

Self-priming:

Our pumps are designed to generate vacuum. It is possible to evacuate all the air from a hose or pipe without damaging the pump (see technical data for suction head information).

Submerged:

The pump can be immersed in fluids. It is important to verify that all components that are in contact with the fluid are chemically compatible. In this case, the air exhaust and fluid must be carried by hoses (optional air connection).

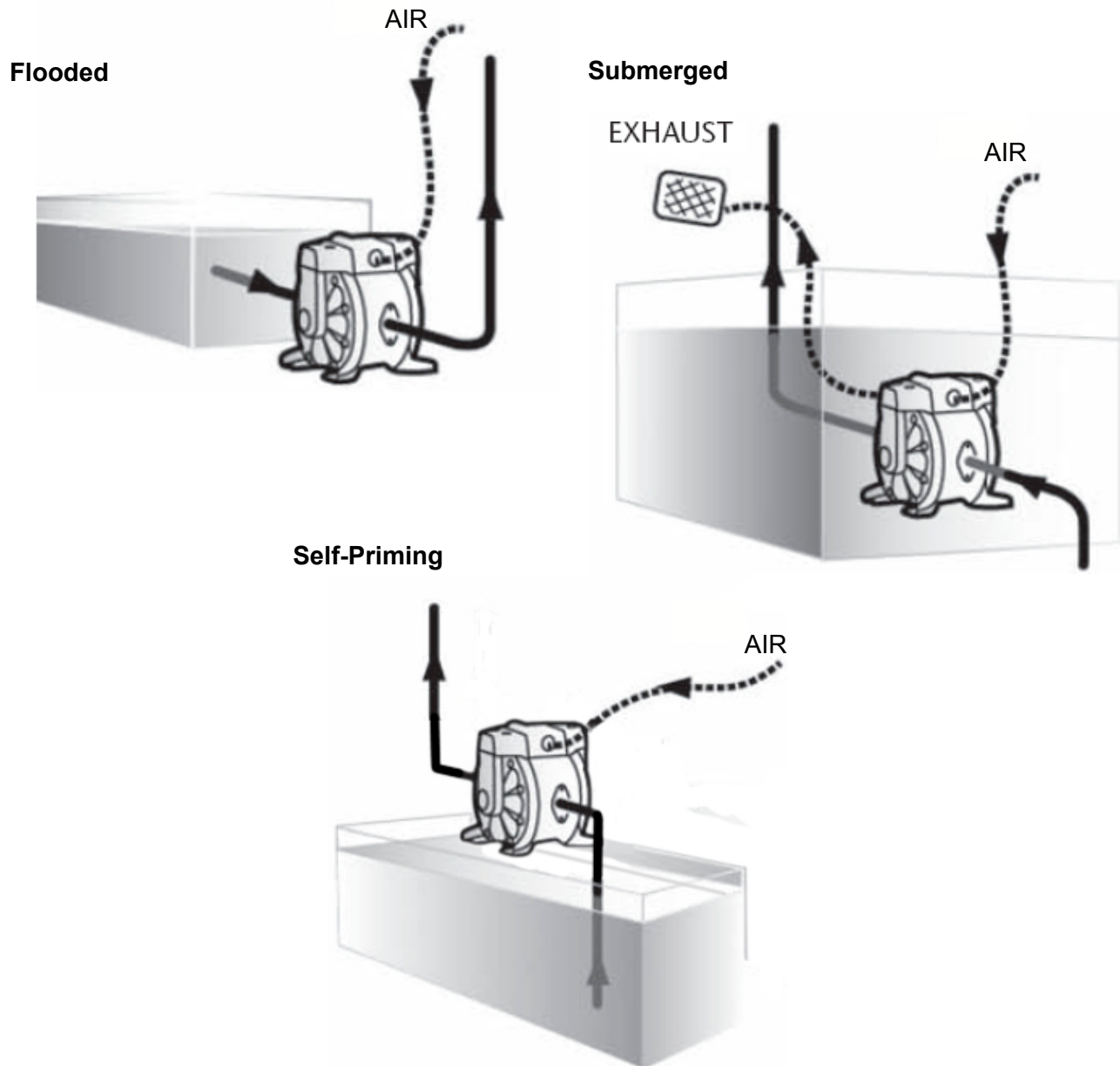

RECOMMENDED INSTALLATION

The figure below shows the recommended configuration for the installation of a diaphragm pump. Read the warnings and recommendations contained in this service bulletin before beginning installation.

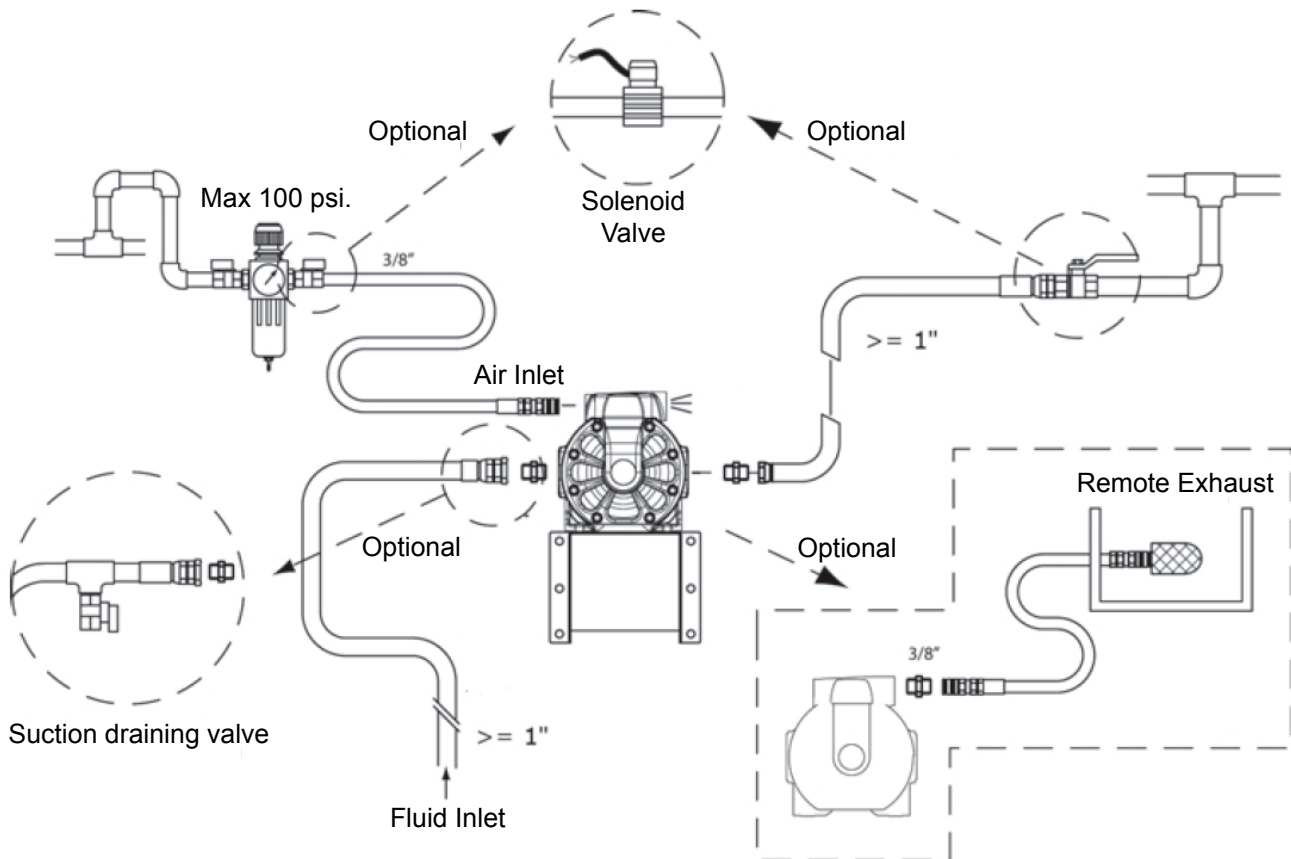

INSTALLATION / OPERATION

1. To achieve long pump life, it is recommended that a filter regulator be installed prior to the air inlet of the pump.
2. Remove the protective packaging from the pump and any protective plugs.
3. Try to minimize the suction head. Install the pump as close as possible to the fluid being pumped.
4. Install the pump in the desired location, use brackets to secure its base. Remember to leave enough space around the pump to perform maintenance tasks.
5. Connect the inlet and outlet (suction and discharge) of the pump to the piping system. Ensure that these are connected correctly and securely.
6. If the pump is to be installed in a place where a spill of fluid can cause an environmental impact, the exhaust should be directed to a place where this spill could be contained (do not use an exhaust hose over 16 ft. in length).
7. Fasten all bolts per the torque specifications on page 13.
8. Fit and secure the air inlet hose, open the valve/dispensing nozzle nearest the pump, and slowly increase the air pressure letting the pump slowly cycle until it primes (see note on page 7).
9. Ensure there are no leaks either on the air inlet or at the fluid outlet. To obtain maximum vacuum all connections should be sealed and tight.
10. Slowly increase the air pressure to optimum working pressure.



NOTE

- To ensure that the air supply is sufficient to meet the demand of the pump, the diameter of the air supply tubing/piping/hose must be equal to the diameter of the air inlet port of the pump. Choose auxiliary air treatment equipment and fittings with sufficient air flow to exceed the air consumption of the pump. In addition, peripheral air treatment equipment must be installed as close as possible to the pump.
- This pump is self-priming. To prime it the first time, adjust the regulator to a low pressure setting while keeping the outlet valve open. When fluid begins to flow from the pump outlet, the pump is primed. For regulation of fluid pressure, the unit must be supplied with air pressure between 43.5 and 100 psi. Adjust the discharge side to control flow. For the performance characteristics of the pump see the pump curve on page 3.



WARNING

- Use flexible hoses to absorb the vibration of the pump and ground the pump.
- Ensure the connections to the pump are not supporting any external weight. Take care that the pump does not support any part of the weight of the hose and piping.
- Use properly rated hoses that can support the action of the suction and discharge pressures. Ensure hoses are compatible with the product being pumped.
- Use hoses and connections equal to or greater than the diameter of the connections to the pump. If a smaller diameter hose/connection is used it can decrease the performance of the pump.
- If pumping fluids that contain solids, verify that the particle size does not exceed the specified limitations listed in the technical data on page 3. If the particle size is exceeded, install a strainer/filter prior to the inlet of the pump to catch larger particles.
- When testing for a pipeline leak, **do not** apply pressure to the inlet and outlet sides of the pump with compressed air. This can cause the diaphragms to rupture.



CAUTION

- Before starting the pump, always ensure that the discharge piping system is secure
- Check the flow direction before starting
- Never use compressed gases other than air
- As you start to close the discharge valve the air supply pressure can increase. Make sure that the pressure stays within the normal operating range (see technical data on page 3)
- The suction flow velocity of the fluid will vary depending on the viscosity and specific gravity of the fluid, the capacity for suction stroke and other conditions, however, if the speed of the pump (the fluid flow rate) increases significantly, there can be cavitation of the fluid and it will reduce pump performance. Adjust the air supply pressure and flow to prevent cavitation.
- If there is no fluid flow after starting the pump, or you hear an unusual noise or notice any irregularities, immediately turn off the pump.
- You can stop the pump by closing the discharge valve while the air is on, but if this condition continues for several hours and the pump is left unattended it can begin pumping automatically if a discharge pipe or connection starts to leak. When the dispense is complete, release the internal pressure and close the discharge valve
- When the pump stops while pumping liquids containing heavy loads of solids, the particles in the slurry precipitate in the outlet chamber. If the pump is restarted without removing the contaminants, the diaphragm may be damaged or the pushing rod can be overloaded and be damaged. Before restarting the pump, flush the remaining fluid and solids from the pump.
- If the pump will remain out of use for a long period of time, purge and clean it.

STOPPING THE PUMP

1. Close the inlet valve of the pump and stop the air supply
2. For safety, ensure that the air valve is closed
3. Turn off the air compressor, or close the valve on the air supply side of the auxiliary equipment
4. Close the discharge valve on the discharge side, then begin to slowly open the drain valve and discharge the fluid pressure
5. Open the air valve of the pump, turn on the pump and flush the remaining fluid
6. After ensuring that the pump was turned off and the pressure was released, fully open and close the regulator valve and drain valve of the pump

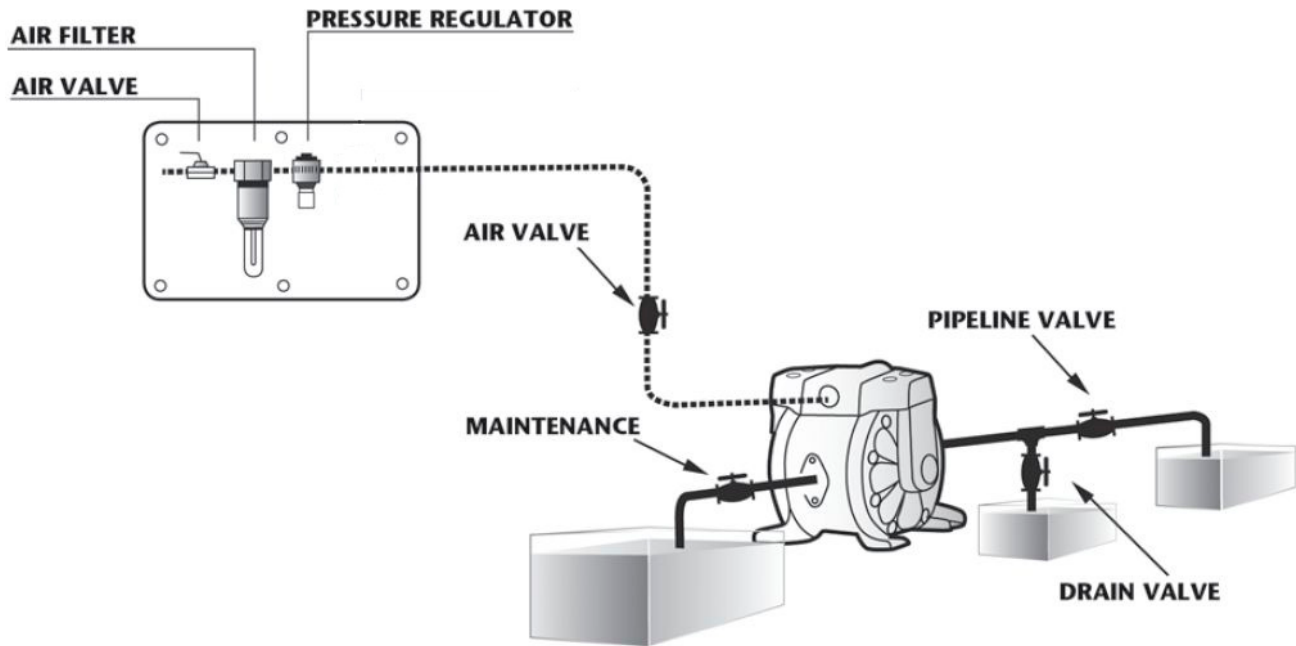

GROUNDING THE PUMP

1. When installing the pump, be sure to perform grounding in the specified location (shown at right)
2. Also connect ground wires for any auxiliary equipment and piping
3. Use a grounding cable of at least 12 gauge

⚠ WARNING

- Connect grounding wires to the pump, piping and all other equipment.
- When the pump operates ungrounded or with an incorrect connection, friction between parts and abrasion caused by some fluids that flow through the pump, can generate static electricity. Moreover, according to the type of fluid being pumped and the installation environment (such as gases in the air or the type of the surrounding facilities) static electricity can cause fire or electric shock.

STICKER THAT SHOWS THE POSITION OF THE GROUND WIRE

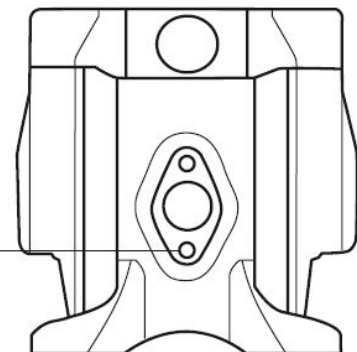

TROUBLESHOOTING

The pump does not work / will not run	
Cause	Remedy
The discharge valve on the discharge side is not open	Open the discharge valve
No air supply	Turn on the compressor & open the air valve & air regulator
The air supply pressure is low	Check the compressor & the configuration of the air line
Air leaks in connecting elements	Check the connection elements & tightness of the screws
Air pipe or ancillary equipment is clogged	Check & clean the air line
Exhaust port (muffler) is clogged	Check & clean the exhaust port & muffler
Fluid line is clogged	Check & clean the fluid line
Pump is clogged	Remove, inspect & clean the pump body

The pump runs but no fluid comes out	
Cause	Remedy
The valve on the suction side is not open	Open the suction valve
Too much suction or discharge height	Confirm the configuration of the pipe & reduce the height
Fluid line discharge side (including filter) is clogged	Check & clean the fluid line
Pump is clogged	Disassemble, check & clean the pump
Ball & ball seat is worn or damaged	Inspect & replace parts

Poor / Decreased flow	
Cause	Remedy
Air supply pressure is low	Check the compressor & the configuration of the air line
Air line or peripheral equipment clogged	Check & clean the air line
Valve on discharge side will not open normally	Adjust the discharge valve
Air mixes with the fluid	Replenish fluid & check configuration of of the suction line
Cavitation occurs	Adjust air supply pressure & discharge pressure. Reduce the flow of the inlet valve to adjust pressure & volume of fluid
Vibrations	Adjust air supply pressure & discharge pressure. Reduce the flow of the inlet valve to adjust pressure & volume of fluid
Ice formation in the air exhaust	Remove ice from the air bypass valve, check & clean the air filter. Use a pipe in the air exhaust so that ice does not form in the muffler
Fluid line (including strainer) clogged	Check & clean the fluid line & strainer
Exhaust port (muffler) clogged	Check & clean exhaust port & muffler
Pump is clogged	Disassemble, check & clean the pump

Leakage of fluid through the exhaust (muffler)	
Cause	Remedy
Diaphragm(s) is damaged	Inspect pump & replace the diaphragm(s)

Irregular noise	
Cause	Remedy
Air supply pressure is too high	Adjust air supply pressure
Pump is clogged with sludge	Disassemble, check & clean the pump

TROUBLESHOOTING

Irregular vibration	
Cause	Remedy
Pump support loose	Check pump support bolts and mounting surface bolts
Air supply pressure is too high	Adjust air supply pressure
Range & ball valve vibrates	Adjust air supply pressure & exhaust pressure

Air in fluid output	
Cause	Remedy
Diaphragm is damaged	Replace diaphragm
Suction hose loose or broken	Tighten or replace

Powered air leak pressure of 43.5 to 100 psi	
Cause	Remedy
Worn Air Valve	Replace air valve components

Pump will not start & is leaking air without cycling	
Cause	Remedy
Stiff air sensors	Replace air sensor
Worn Air Valve	Replace

Repair Kits

Model 1120-024

Part Number	Description	Items included in kit
833212	Air valve kit	1-1 through 1-11 (comes pre-assembled)
833207	Stroke sensor kit	6-1 through 6-6 (X2)
833213	Check ball kit	2 (qty of four)
833214	Ball seats, o-rings, ball guides	3-1 through 3-3 (X4)
833215	Bushing, seal, push rod (Prior to 2/1/2013)	4-1 through 4-4
833334	Bushing, seal, push rod (After 2/1/2013)	4-1 through 4-4
833339	Diaphragms kit (After 2/1/2013)	5-1 through 5-2 (qty of two)
833342	Retrofit Kit*	5-1 (x2), 5-2 (x2), 4-4 (x1)

Model 1120-026 / 1120-031

Part Number	Description	Items included in kit
833212	Air valve kit	1-1 through 1-11 (comes pre-assembled)
833207	Stroke sensor kit	6-1 through 6-6 (X2)
833233	Check ball kit	2 (Qty of four)
833234	Ball seats, o-rings, ball guides	3-1 through 3-3 (X4)
833235	Bushing, seal, push rod (Prior to 2/1/2013)	4-1 through 4-4
833335	Bushing, seal, push rod (After 2/1/2013)	4-1 through 4-4
833339	Diaphragms kit (After 2/1/2013)	5-1 through 5-2 (X2)
833342	Retrofit Kit*	5-1 (x2), 5-2 (x2), 4-4 (x1)

*Include diaphragms, diaphragm nuts, & central shaft - Updates pumps prior to 2/1/2013 to new design.

PARTS DIAGRAM

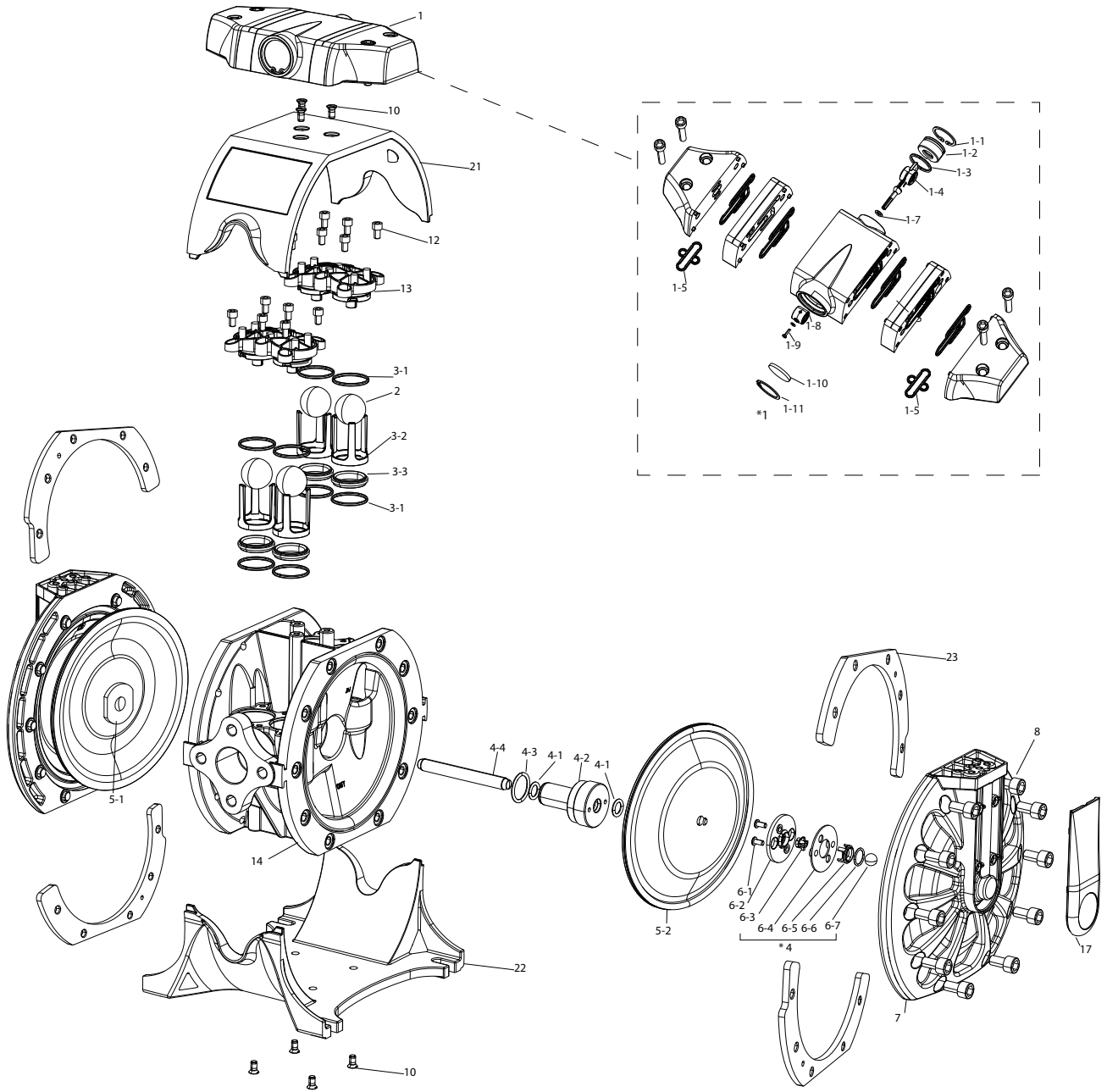

AIR VALVE

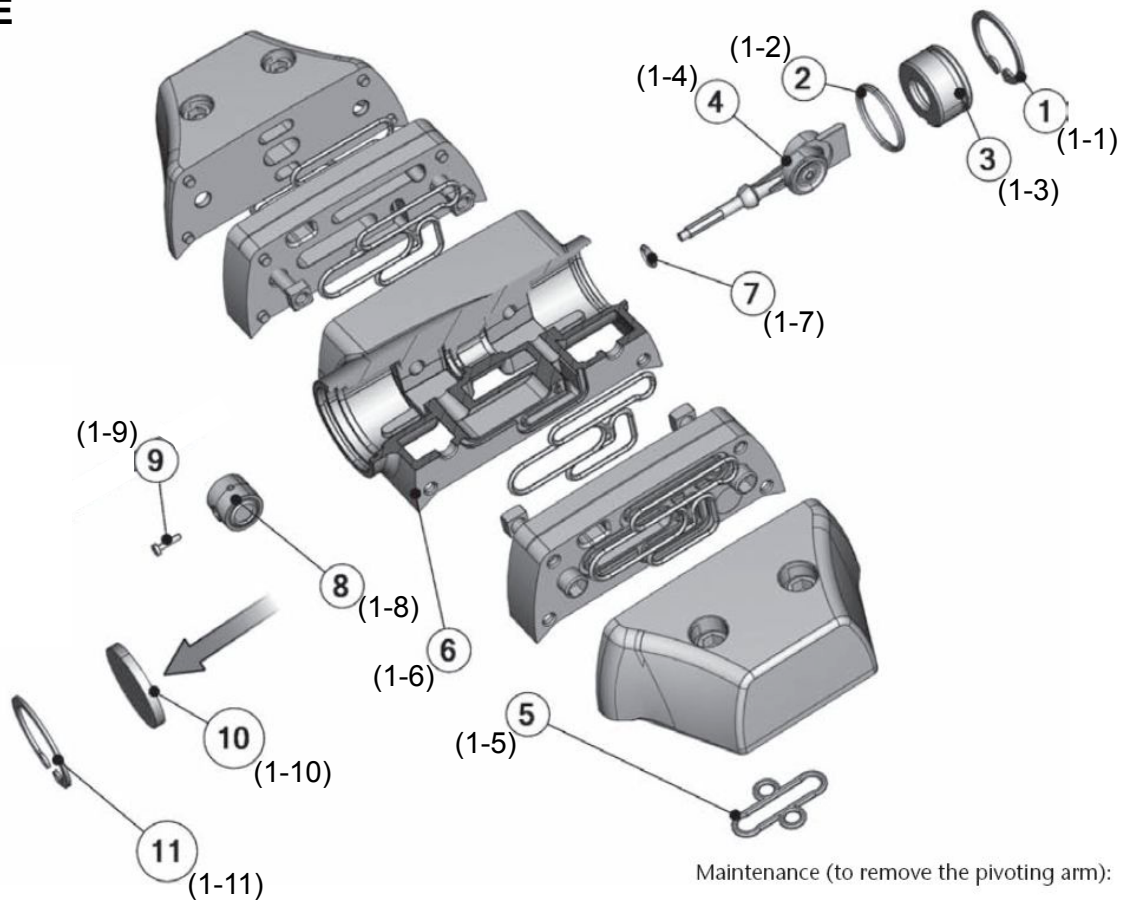

Maintenance (to remove the pivoting arm):

1. Remove 1, 2, 3, 10, 11
2. Remove 9
3. Remove 4, 7, 8

PUMP PART IDENTIFICATION LIST

Item	Description	Qty
1	Air valve	1
2	Check ball	4
3	Ball check seats / O-rings / Ball Guides	*
4	Bushing / Seal / Push rod	*
5	Diaphragms	2
6	Air sensor	*
7	Diaphragm cover	2
8	Diaphragm cover bolt	20
10	Diaphragm cover nuts	7
12	Diaphragm cover washer	12
13	Valve cap	8
14	Body	1
17	Cover	2
21	Upper shield	1
22	Lower shield	1
23	Shield attachment (1120-026 only)	4

AIR VALVE KIT PARTS LIST

Item	Description	Qty
1	Air inlet snap ring	1
2	O-ring	1
3	Inlet adaptor	1
4	Pivoting arm	1
5	Distributor lower seal	2
6	Air valve body	1
7	O-ring	1
8	Sealing drum	1
9	Bolt	1
10	Muffler	1
11	Air outlet snap ring	1

*Quantities are as shown on parts diagram (page 11)

MAINTENANCE & REPAIR

Tools Required	
Torque wrench	0 to 150 in. lbs. (0 to 15 N-m)
Allen wrenchs	3 mm, 4mm, 5mm, 6mm
Snap Ring Pliers	

Torque Specifications	
Diaphragm Cover	137.7 in. lbs. (15 N-m)
Air Valve	44.25 in. lbs. (5 N-m)
Valve Cap (1120-024)	35.4 in. lbs (4 N-m)
Valve Cap (1120-026)	30.9 in. lbs. (2 N-m)



NOTE

For proper operation of the pump and to prevent accidents which may damage equipment and in worst case cause bodily harm, the torques for the **DIAPHRAGM COVERS** and **AIR VALVE** must be checked periodically.

DIAPHRAGM REPLACEMENT



CAUTION

Before beginning this maintenance procedure, disconnect the air supply from the pump. It is not necessary to remove the pump from the fluid line.

1. Close fluid valves
2. Drain the fluid inside the pump. Follow the pressure relief procedure on this page.
3. Remove the air valve while taking care not to damage the seals (1-5) shown below right.

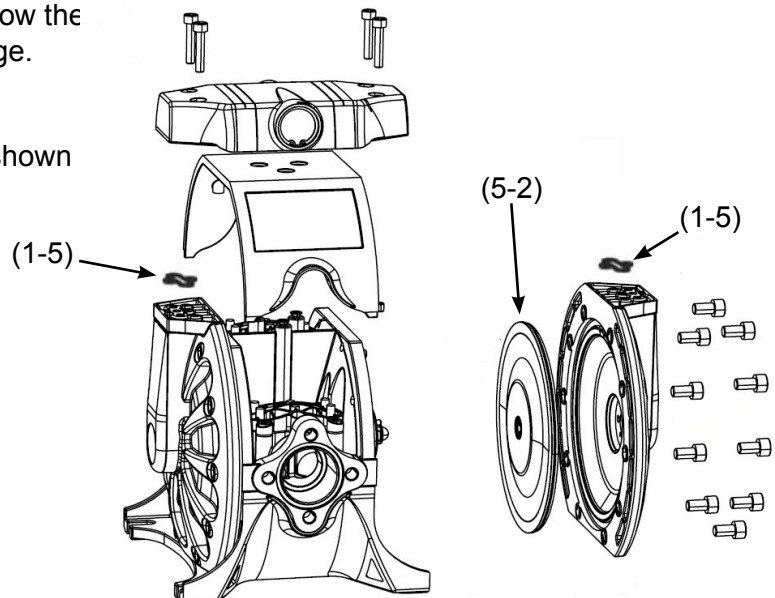



WARNING



PRESSURE RELIEF PROCEDURE:
Follow this procedure whenever you shut off the pump, when checking or servicing any part of the system and when installing, cleaning or changing any part of the system.

- 1) Disconnect the air to the pump.
- 2) Point dispensing valve away from yourself and others.
- 3) Open dispensing valve until pressure is relieved.

4. Remove the diaphragm cap.
5. Remove the cover by gently pulling back.
6. Remove the used diaphragm (5-2) shown below.
7. Place the new diaphragm in the proper position.
8. Reassemble the pump and torque all bolts per the torque specifications on this page.

CHECK BALL/VALVE REPLACEMENT

1. Close fluid valves
2. Drain the fluid inside the pump. Follow the pressure relief procedure on page 13.
3. Remove the air valve while taking care not to damage the seals (1-5) shown on page 13.
4. Removed the valve cover by loosening the screws. Take note of the orientation of of the cap, as it is critical to replace it correctly during reassembly.
5. Install a new set of valves according to the assembly drawings below. Ensure that the ball guides are assembled as shown, and tighten the screws per the torque specifications table on page 13.
6. Assemble the air valve taking care not to damage the O-rings. Tighten the screws per the torque specifications table on page 13.

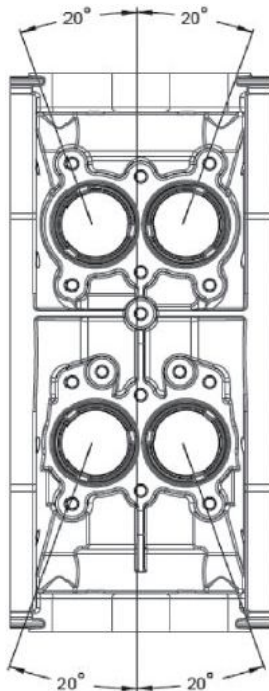



CAUTION

TO AVOID FLUID RESTRICTIONS AND LEAKAGES, PAY ATTENTION TO THE POSITION OF THE BALL GUIDES SHOWN IN THE FIGURE BOTTOM LEFT.

THE CHECK BALL CAPS MUST BE PLACED WITH THE INDICATED AREA OF THE FIGURE BELOW FACING THE BODY.

Check ball cap position)

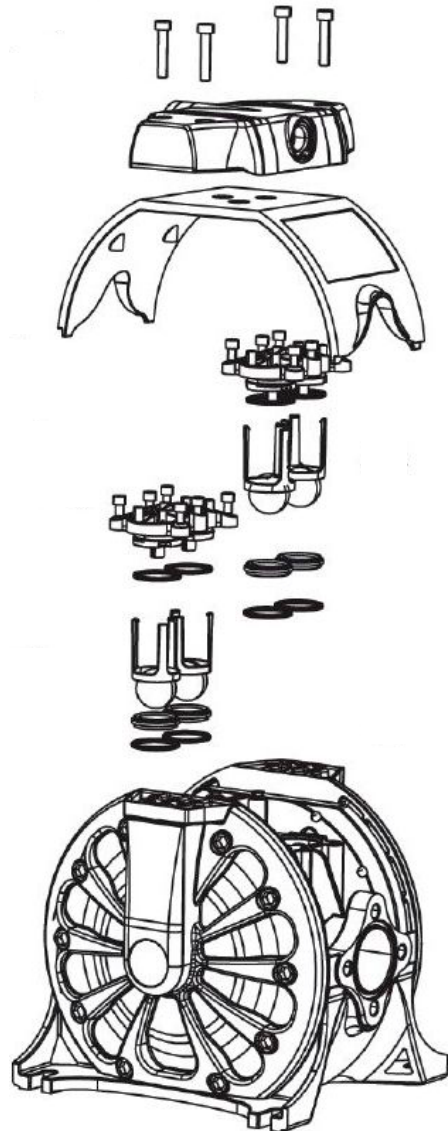
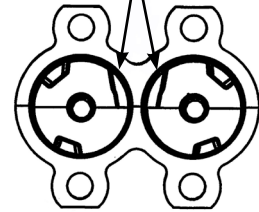

STROKE SENSOR REPLACEMENT

The air sensors are on the inside part of the diaphragm covers. To access them, follow the procedure for “Diaphragm Replacement” on page 13. Once the covers are removed follow the steps below.

1. Remove the two screws that secure the air sensor to the top.
2. Remove all components of the sensor and clean the area.
3. Install new components in the order shown below.
4. Reassemble the pump and tighten all bolts per the torque specifications on page 13.

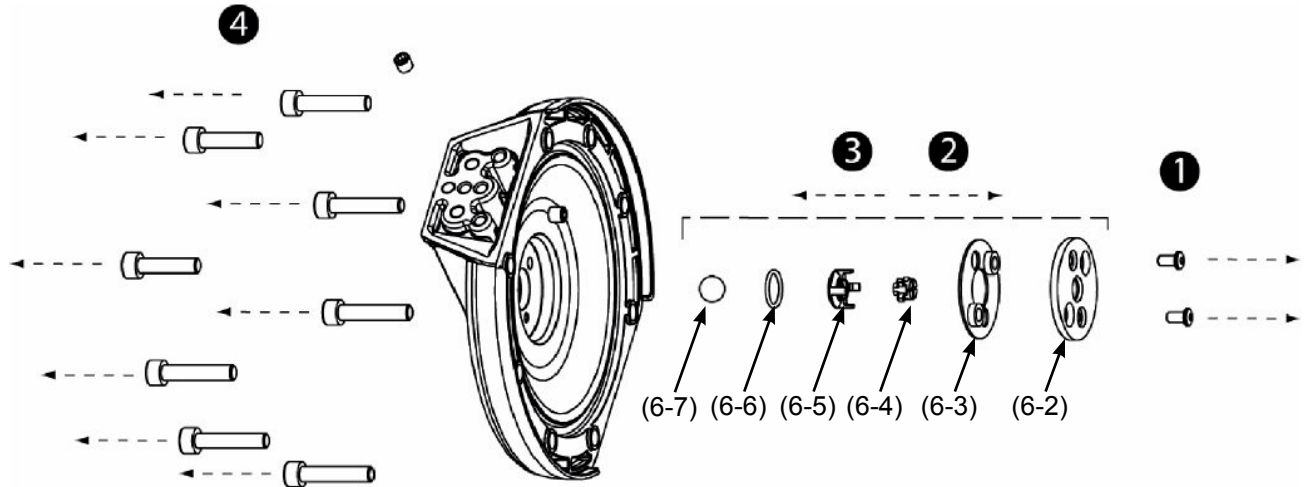

PUSH ROD REPLACEMENT

To access the push rod, the diaphragm cover must be removed. Follow the procedure for “Diaphragm Replacement” on page 13. Once the cover is removed follow the steps below.

1. Remove the shaft from its housing by pulling it from one end. The teflon sleeve is threaded into the body. To remove use snap ring pliers in the two holes indicated in the figure below.
2. Once the cap has been removed, remove the quad ring inside the pump body.
3. Replace the parts in the correct order as shown in the assembly drawing below.
4. Reassemble the pump and tighten all bolts per the torque specifications on page 13.

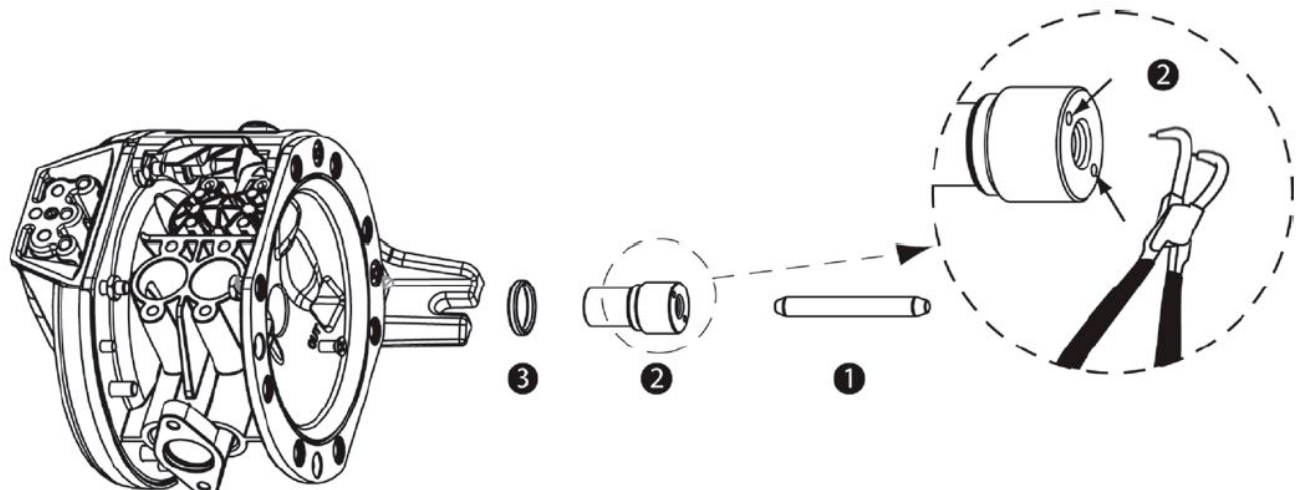

**For Warranty Information Visit:
www.balcrank.com**

Balcrank® Corporation
Weaverville, NC 28787
800-747-5300
800-763-0840 Fax
www.balcrank.com

Revision Log:

Rev. A - New release
Rev. B - Added kit part numbers for pumps manufactured
after 2/1/2013 and added part number for retrofit
kit for pumps manufactured prior to 2/1/2013
Rev. C - Removed obsolete items from repair kit list

SERVICE BULLETIN SB1124
Revision C 12/15