

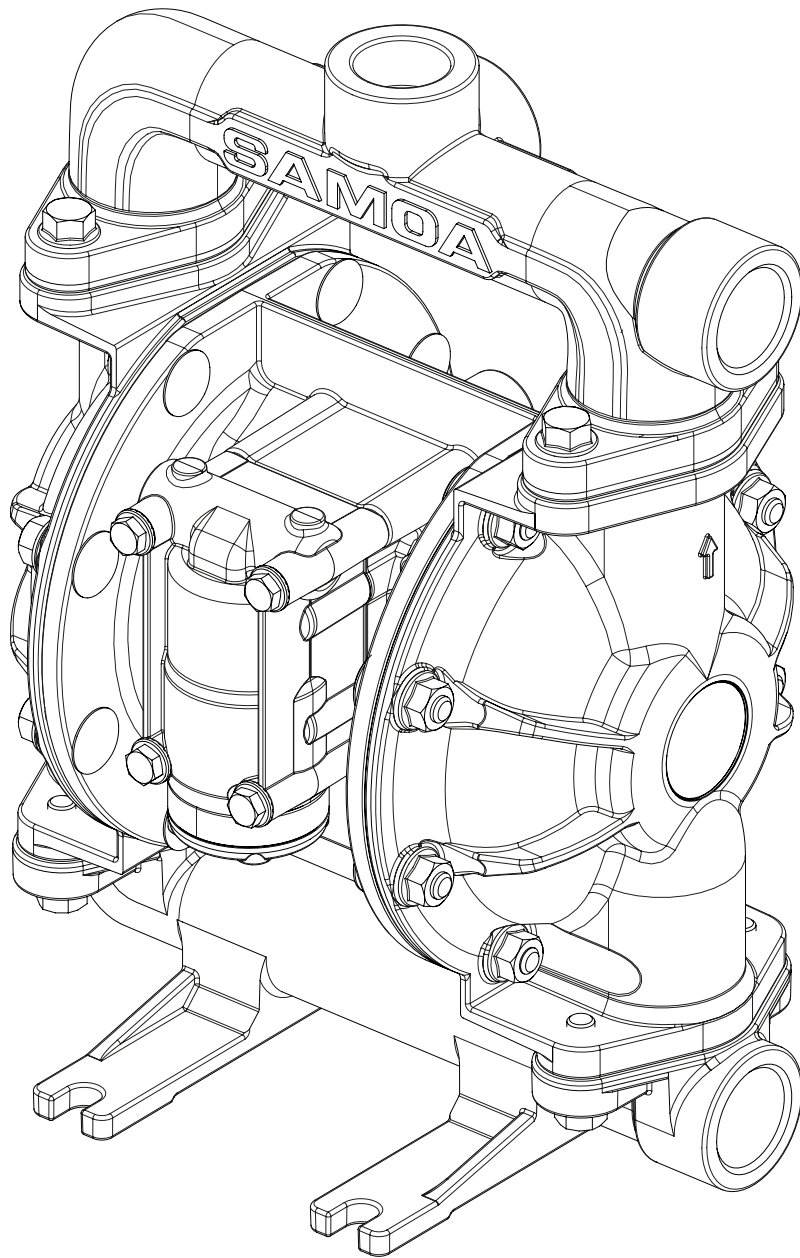

**PIVOT**  
UNIVERSAL PUMP

# CP10

EN INSTRUCTIONS



CP10 1" DOUBLE DIAPHRAGM METALLIC PUMP



1. WARNINGS .....	6
2. PUMP NOMENCLATURE .....	8
3. TECHNICAL DATA .....	8
4. PERFORMANCE CHART .....	9
5. DIMENSIONS .....	10
a. Aluminium Version .....	10
6. DESCRIPTION .....	11
a. Installation Recommendations .....	11
b. Remote Exhaust Installation (optional) .....	12
c. Air Connection .....	12
7. OPERATION .....	13
a. Stopping the Pump for Maintenance Tasks .....	13
b. Grounding the Pump .....	13
c. ATEX Certified Pumps .....	13
8. TROUBLESHOOTING .....	14
9. MAINTENANCE .....	15
a. Torque Specifications .....	15
b. Air Valve and Exhaust .....	15
c. Air Sensor .....	16
d. Shaft, Bushing and Seals .....	16
e. Balls and Seats .....	17
f. Diaphragms .....	18
10. CE CERTIFICATE .....	19
11. KITS .....	

-  Product pictures and specifications are subject to change without prior notice. The English version is a translation of the original document in Spanish. In case of a discrepancy, the original will prevail.

### EQUIPMENT MISUSE HAZARD



- This equipment is for professional use only.
- Do not tamper the equipment.
- Use the equipment only for its intended purpose.
- Use only original replacement parts from Samoa Industrial, S.A.
- Install and use the pump following all local and national regulations including all health and safety laws and regulations.
- Avoid unnecessary damage to the pump. Do not allow the pump to run for long periods of time without fluid (dry). Disconnect the pump from the air line when the system is idle for long periods of time.

### CHEMICAL COMPATIBILITIES AND TEMPERATURE LIMITS



- Chemical compatibility can change with temperature and concentration of chemicals within the fluids being pumped, discharged or circulated. For specific fluid compatibility, consult the chemical manufacturer.



- Maximum temperature limits are based upon mechanical stress only. Certain chemicals will significantly reduce maximum safe operating temperatures. Consult the chemical manufacturer for temperature limits.



- Fluids that are not compatible with the pump materials can cause damage to the pump and may cause serious personal injuries. Always consult your authorized Samoa supplier if you have questions regarding the pump and fluid compatibility.

- Do not exceed material temperature limits:

MATERIAL	TEMPERATURE RANGE
PTFE	-10 °C / +107°C / -14 °F / +225 °F
NBR	-23 °C / +82 °C / -10 °F / +180 °F
Acetal	-40 °C / +120 °C / -40 °F / +250 °F
Hytrel®	-29 °C / +104 °C / -20 °F / +220 °F
Neoprene	-18 °C / +93 °C / 0 °F - 200 °F
Santoprene®	-40 °C / +135 °C / -40 °F / +275 °F
Viton®	-40 °C / +177 °C / -40 °F / +350 °F
Polypropylene	0 °C / +65 °C / +32 °F / +150 °F
PVDF (Kynar®)	-40 °C / +121 °C / -40 °F / +250 °F

### SAFETY MEASURES



- Ensure that operators using this equipment are trained on the operation, the product and its limitations.
- Use safety equipment as required.



- Do not use a model with aluminium wetted parts to pump fluids for human consumption, there is a possibility of trace contamination of lead.



- Do not exceed the maximum air pressure. Make sure that hoses and other components are rated for the pump maximum working pressure. Check all hoses for damage or wear.



- Never use a pump that leaks, that is damaged, that is corroded or otherwise it may lack the capacity to contain the fluid.



- Frequently check that the bolts on the pump fluid covers are correctly torqued.
- Check the diaphragm conditions. If a diaphragm is broken, the fluid can leak out of the air exhaust and cause personnel injuries or contaminate the environment.
- When handling hazardous fluids, always route the air exhaust into a suitable container and locate it in a safe place. Install a suitable container surrounding the pump to prevent any leaks or spills.

### FIRE AND EXPLOSION HAZARD





- Prevent static sparking. If static sparking occurs, fire or explosion could result. Pump, valves, and containers must be properly grounded when handling flammable fluids and whenever discharge of static electricity is a hazard.



- Danger of explosion if 1,1,1-trichloroethane, methylene chloride or other halogenated hydrocarbon solvents are used with wetted parts made from aluminium. It could cause serious injury and property damage. Check the motor section of the pump, fluid covers, manifolds and all wetted parts in order to ensure compatibility before using these solvents.
- In order to avoid hazardous conditions that can cause fire or explosion all label and marking material must be cleaned to enable proper reading.

Examples: CP10X-XXX-XXX

CP10X		XXX			XXX		
PUMP TYPE	AIR MOTOR	HOUSINGS			WETTED PARTS		
1	2	3	4	5	6	7	8
Pump Type & Size	Central Body & Air Chambers	Fluid Ports / Location Multiport manifolds: central and lateral	Fluid Chambers & Manifolds	Hardware Bolts	Valve Seats	Valve Balls	Diaphragms Type & Material
CP10 Universal Pump (Bolted)	 ATEX Certified A*= Aluminium	B = 1" BSP threaded ports N = 1" NPT threaded ports	 ATEX Certified A*= Aluminium	C = Carbon steel	Soft seats: H = Hytrel® M = Santoprene® N = Nitrilo (Buna-N)  Hard seats: A = Aluminium S = Acero inoxidable AISI 316	H = Hytrel® M = Santoprene® N = Nitrilo (Buna-N) S = AISI 316 Stainless Steel T = PTFE (Teflon®)	Conventional: A = Santoprene® C = Hytrel® G = Nitrilo (Buna-N)  Two-piece Z = PTFE (Teflon® with Santoprene® backer)

\* ATEX Certified pumps for use in hazardous locations ATEX Group II 2GDx.

Hytrel® is a registered trademark of the DuPont Company, Viton® & Teflon® of the Chemours Company and Santoprene® of the Monsanto Company, licensed for Advanced Elastomer Systems, L.P. Kynar® is a registered trademark of Arkema, Inc.

### 3. TECHNICAL DATA

	METALLIC CP10 - PIVOT SERIES
PRESSURE RATIO	1:1
MAXIMUM FREE DELIVERY	130 l/min (35 gal/min)
AIR PRESSURE OPERATING RANGE	1,5 to 8 bar (20 to 120 psi)
MAXIMUM SIZE SOLIDS IN SUSPENSION	3,2 mm (1/8")
MAXIMUM DRY SUCTION LIFT	5 m (16')
MAXIMUM WET SUCTION LIFT	8 m (26')
DISPLACEMENT PER CYCLE*	0,4 l (0.1 gal)
FLUID INLET AND OUTLET CONNECTIONS (MULTIPORTS)	1" BSP (F) / 1" NPT (F)
AIR INLET CONNECTION	3/8" NPT (F)
AIR EXHAUST CONNECTION	1/2" NPT (F) (optional)
SOUND LEVEL	75 dB (A) @ 50 cycles/min @ 5 bar (70 psi)
WEIGHT: ALUMINIUM	Threaded 5,4 kg (12.1 lbs)

\*Delivery per cycle depends on the diaphragm material, air inlet and fluid viscosity.

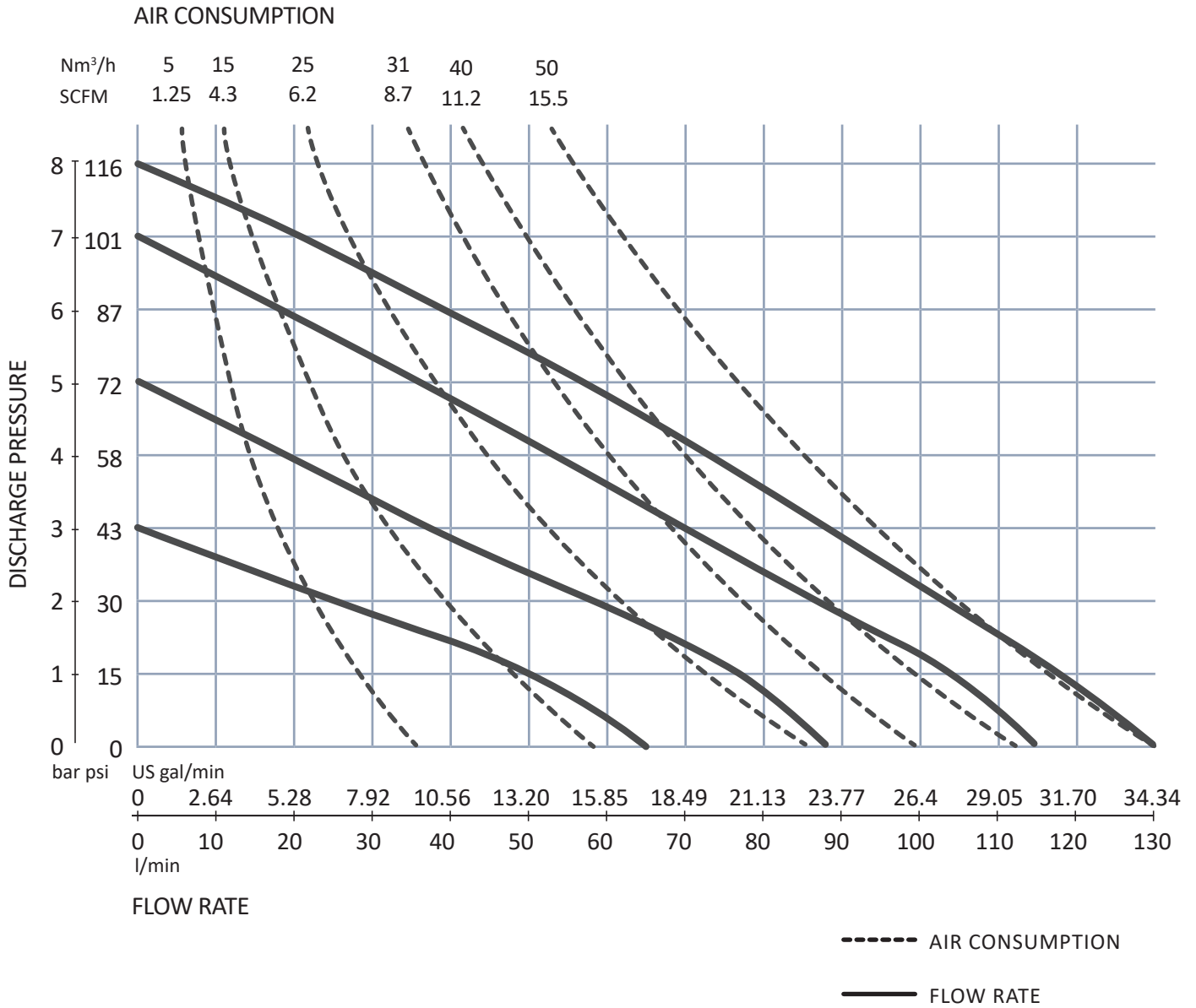

Tested at room temperature, using water. Flooded pump with positive suction head.

a. Aluminium Version

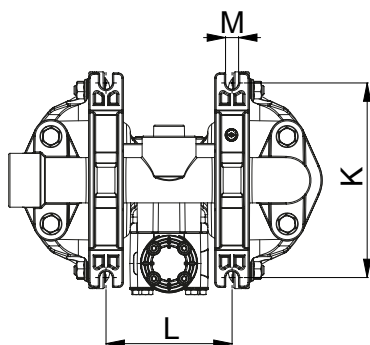
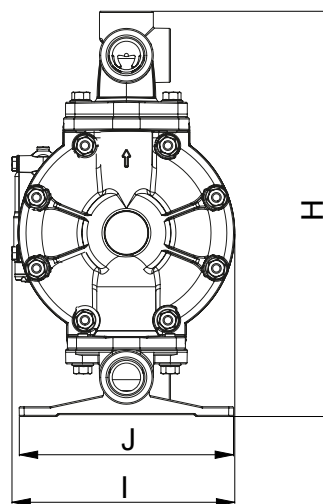
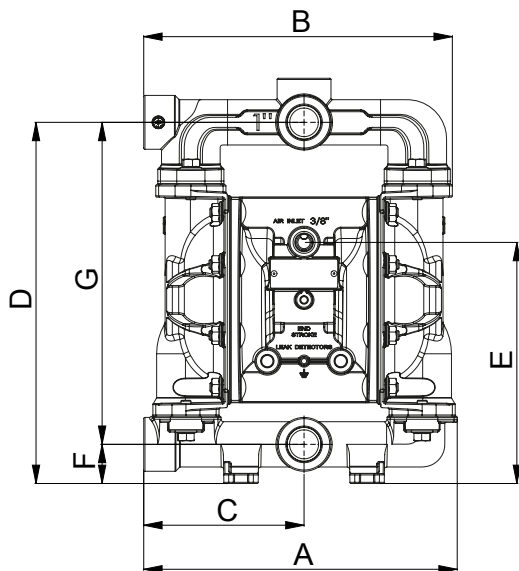
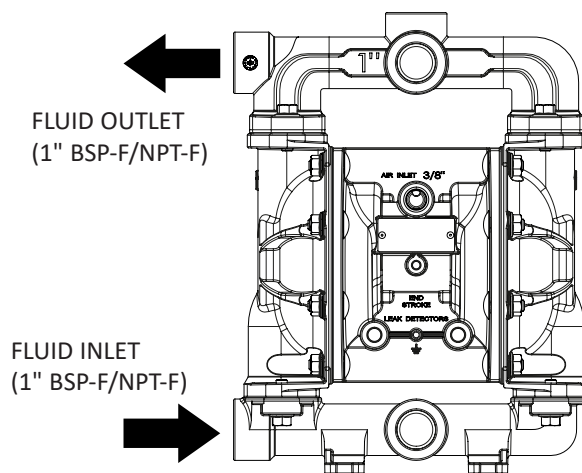
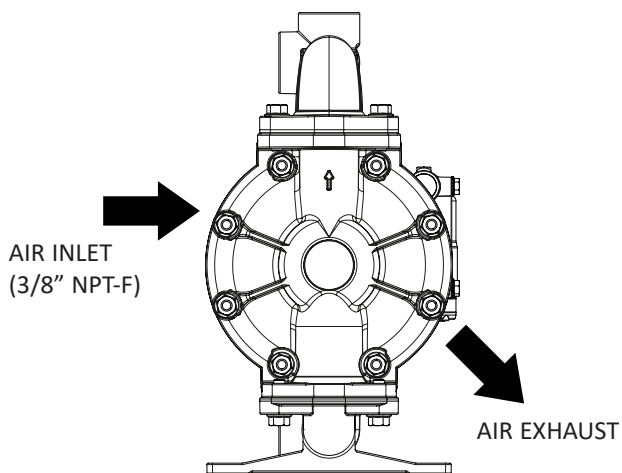

	A	B	C	D	E	F	G	H	I	J	K	L	M
mm	216	207	120	281	197	51	230	299	162	140	124	155	9
in	8.50"	8.16"	4.72"	11.1"	7.75"	2.01"	9.06"	11.77"	6.38"	5.51"	4.88"	6.11"	0.36"



- Air operated double diaphragm pumps are air-powered, reciprocating positive displacement pumps.
- They have two opposite pump volumes and a diaphragm divides each volume into an air and a liquid chamber.
- The diaphragms are connected with a shaft.
- During one pumping stroke, the fluid is suctioned into one of the liquid chambers while simultaneously the other one is discharged.

### a. Installation Recommendations

- Install the pump as close as possible to the fluid being pumped to minimise the suction head.
- For the ease of operation and service, install the pump so there is enough space around it.
- If the pump is installed in a place where fluid leakage can cause an environmental impact, the exhaust should be directed to a place where it can be contained.
- When installing the pump in its place, use brackets to secure its base.
- Fasten all bolts with the torques contained in this manual (MAINTENANCE section). Let the pump running for a whole day. After that, check the torques again.
- Pumps can be installed with flooded suction, suction lift or submerged in the fluid pumped.
- The figure below shows the recommended configuration for the pump installation.

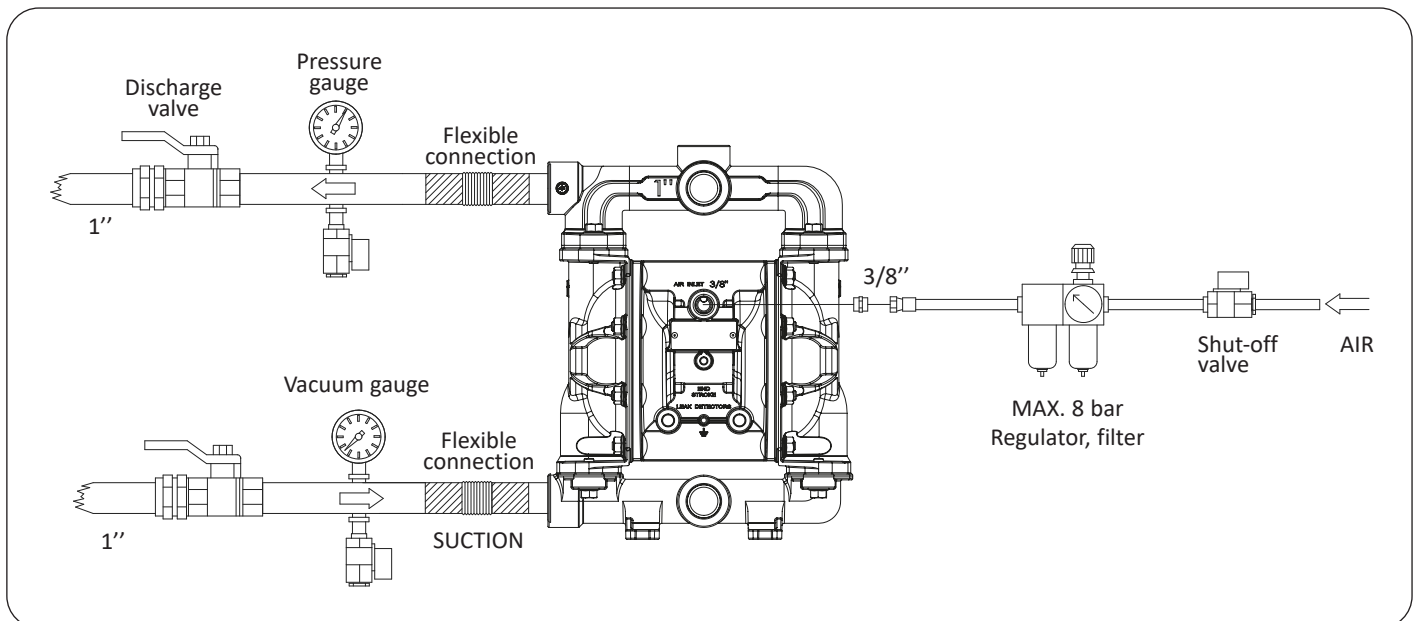

## b. Remote Exhaust Installation (optional)



### WARNING

The pump exhaust should be directed to a safe location to avoid damage to persons and installations.

- Remove the pump air muffler.
- Connect a hose with a 1/2" NPT thread to the new exhaust port and install the muffler at the end of the hose.
- Be sure the air exhaust is directed to a safe place.

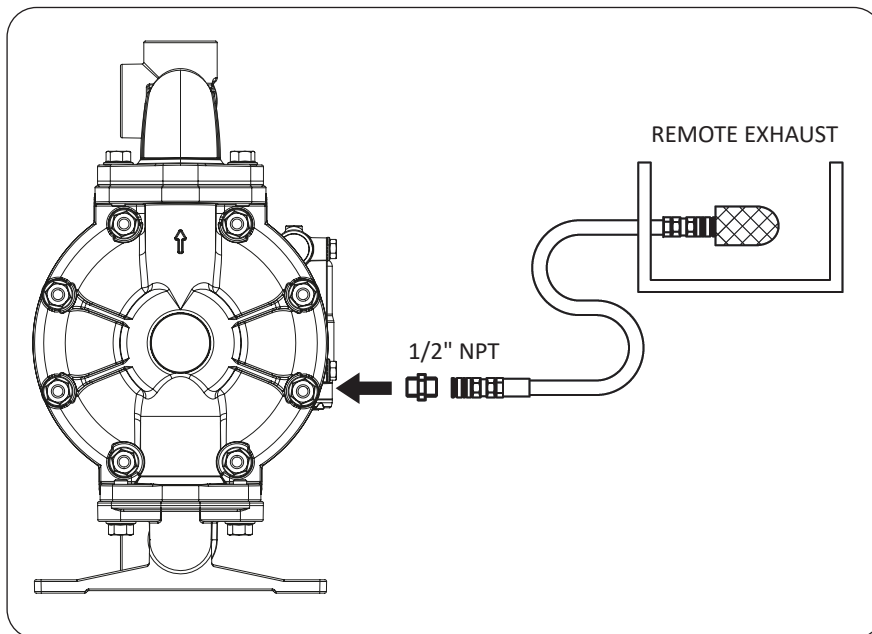

## c. Air Connection



### WARNING

- To ensure that the air flow is sufficient to meet the pump demand, the air pipe diameter must be equal to the pump air inlet.
- Air treatment equipment must be dimensioned to meet pump air demand. It must be installed as close as possible to the pump unit.
- Using air quick couplers to connect the air hoses facilitates pump maintenance.

This pump is self-priming. To prime it for the first time connect the pump air inlet to a low air pressure supply. Keep the outlet valve open and gradually increase the pressure until the fluid comes out of the pump outlet.

For the performance characteristics of the pump see the performance chart (TECHNICAL DATA section).

#### a. Stopping the Pump for Maintenance Tasks

- Shut off the air supply to the pump.
- Close the discharge valve and the suction valve. Open inlet and outlet drain valves if installed.
- Open the air valve of the pump, start up the pump and flush the remaining fluid.
- Close the air valve.
- Maintenance can be started after ensuring that the pump is turned off and the pressure is released.
- Unground the pump.

#### b. Grounding the Pump



#### WARNING

If the pump operates ungrounded or with an incorrect connection, friction between parts and fluid abrasion can generate static electricity. Depending on the fluid pumped and the installation environment, static electricity can cause either fire or electric shock.

When installing the pump, be sure to perform grounding in the specified location if required.

Also connect ground wires for the auxiliary equipment and piping.

Use a grounding cable of at least 12 AWG (2.0 mm).

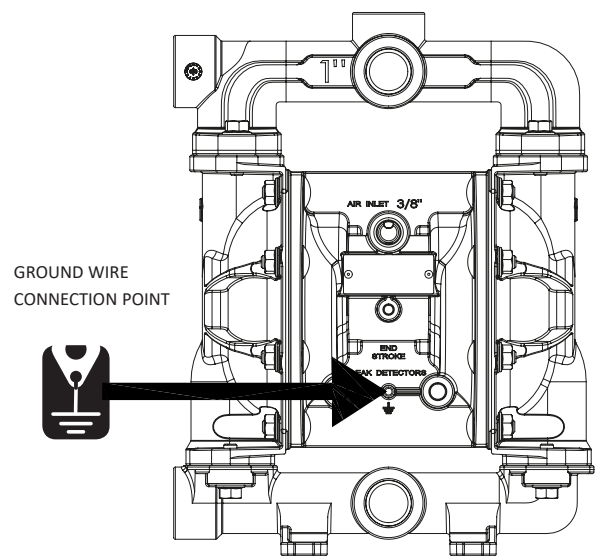

#### c. ATEX Certified Pumps

If your pump is ATEX certified, a specific ATEX manual is included. Read this manual before operating the pump.

If the symbol "Ex" is in the pump nameplate it can be used in the potentially explosive atmospheres indicated areas (details on the ATEX manual).

CAUSE	RECOMMENDED MEASURE
<b>The pump does not work</b>	
Discharge valve on the discharge side is not open.	Open the valve on the discharge side.
No air supply.	Turn on the compressor and open the air valve and air regulator.
Low air supply pressure.	Check the compressor and the air line configuration.
Air leaks in connecting components.	Tighten air connections or replace components.
Air pipes or additional equipment is clogged.	Check and clean the air line.
Pump exhaust port (muffler) is clogged.	Check and clean the exhaust port and muffler.
Fluid pipe is clogged.	Check and clean the fluid line.
Clogged pump.	Remove, inspect and clean the pump.
<b>The pump runs but no fluid comes out</b>	
Valve on the suction side is not open.	Open the valve on the suction side.
Too much suction or discharge height.	Reduce lengths/heights of suction and discharge pipes.
Fluid pipe on the discharge side (including the filter) is clogged.	Check and clean the fluid line.
Clogged pump.	Dismantle the pump, check and clean.
Balls and/or ball seats are worn or damaged.	Inspect and replace parts.
<b>Decreasing flow</b>	
Low air supply.	Check the compressor and the air line configuration.
Air line or peripheral equipment is clogged.	Check and clean the air line.
Valve on the discharge side will not open normally.	Adjust the discharge valve on the discharge side.
Air mixes with the fluid.	Replenish with fluid and check the pipe configuration on the suction side.
Pump is vibrating.	Adjust air supply pressure and discharge pressure. Reduce the inlet valve flow to adjust the pressure and fluid volume. Securely fasten the pump to the base using the mounting feet and appropriate hardware.
Ice formation in the air exhaust.	Remove ice from the air bypass valve and check and clean the air filter. Use a pipe in the air exhaust so there is no ice formation in the muffler.
Fluid line (including the filter) is clogged.	Check and clean the fluid pipe and strainer.
Pump exhaust port (muffler) is clogged.	Check and clean the exhaust port and muffler.
Clogged pump.	Remove, inspect and clean the pump body.
<b>Discharge fluid contains air bubbles</b>	
Damaged diaphragm.	Replace diaphragm.
Loose or broken suction hose.	Tighten or replace.

a. Torque Specifications



**CAUTION**

Do NOT overtighten fasteners. Shut off the air supply before any intervention. Be aware of a possible fluid leakage inside the pump.

For proper pump operation and to prevent accidents, you must periodically review the torques of the diaphragms covers and the directional valve. The table shows the appropriate torques for this purpose:

	CP10A-XAX-XXX Aluminium
Fluid Chamber	25 N·m (18,43 ft·lbs)
Manifolds	25 N·m (18,43 ft·lbs)
Air Motor	6 N·m (4,42 ft·lbs)
Fluid Piston	40 N·m (29,50 ft·lbs)



**CAUTION**

**TIGHTENING SEQUENCE**

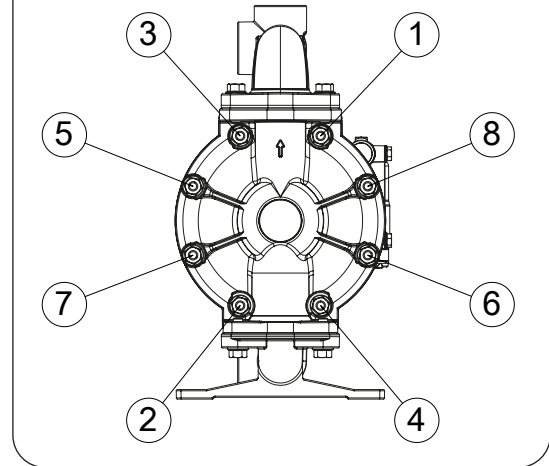

b. Air Valve and Exhaust



**NOTE**

Before performing any maintenance operation on the pump, the instructions described in the "Stopping the Pump for Maintenance Tasks" section of the Operation section should be followed.

1. Unscrew the four air distributor screws and remove the assembly.
2. Remove the 2 lower screws (A) and the air exhaust body if it needs to be replaced.
3. Place the new air exhaust (B) in the new air distributor (C).
4. Screw the assembly to the pump body.

\*Pay attention to the position of the distributor and the exhaust body.

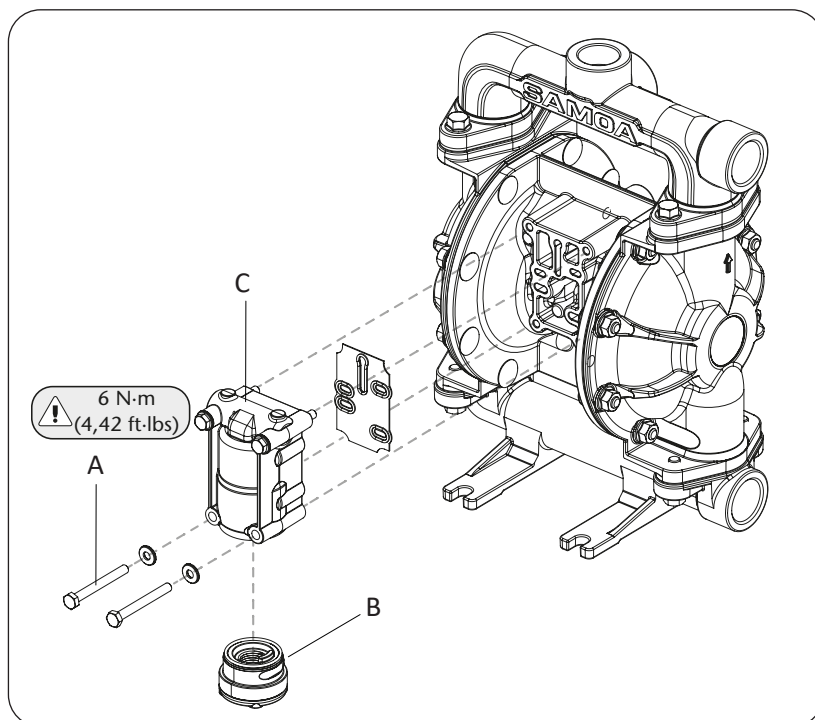

## c. Air Sensor



## NOTE

Before performing any maintenance operation on the pump, the instructions described in the "Stopping the Pump for Maintenance Tasks" section of the Operation section should be followed.

Once the fluid covers are removed proceed as follows:

1. Remove the 4 screws (A) of the air sensor cover.
2. Remove all sensor components. Clean the area.
3. Insert new components in the order shown (B).
4. Fit the sensor cover and tighten the screws.

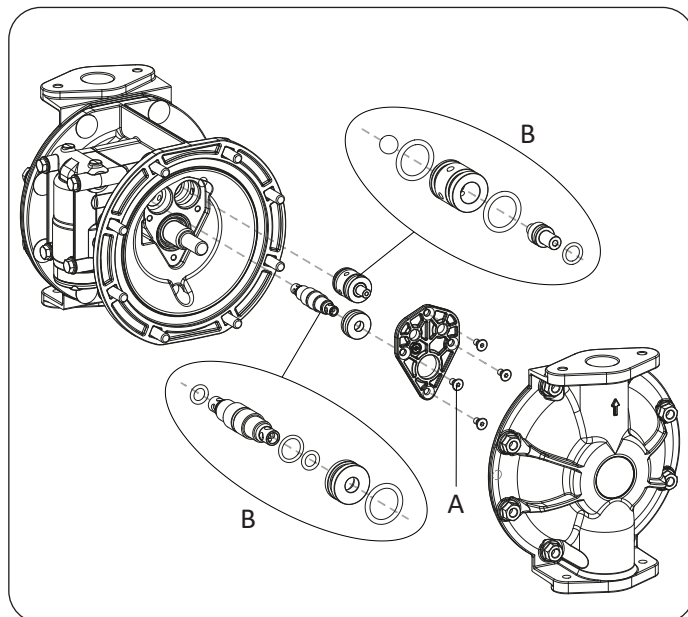

## d. Shaft, Bushing and Seals



## NOTE

Before performing any maintenance operation on the pump, the instructions described in the "Stopping the Pump for Maintenance Tasks" section of the Operation section should be followed.

1. Replace the bushing (A) and the seals (B).
2. Clean and lubricate the area.
3. Fit the remaining components in reverse order.

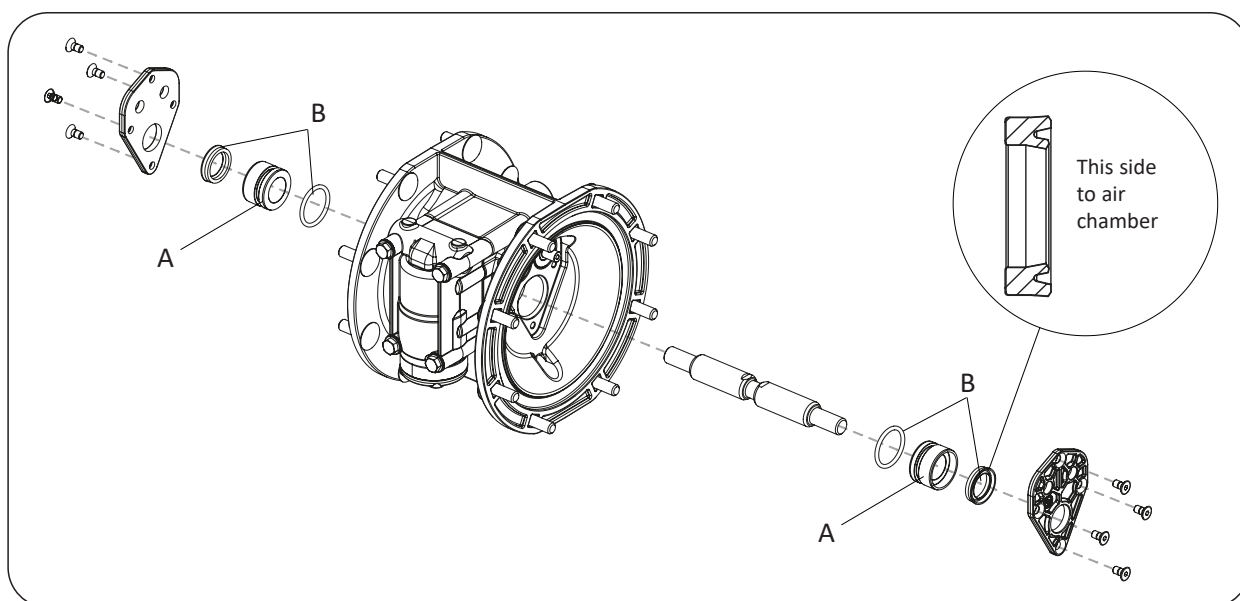

## e. Balls and Seats

**IMPORTANT**

Progressively approach the manifold with the bolts before final tightening.  
Soft seats do not require gaskets and can be installed face up or face down.  
Rigid seats employ additional gaskets.  
The balls must always be placed above the seats.  
If pump maintenance involves disassembly of the manifolds and the pump is configured with PTFE O-rings (white color), these must be replaced with new ones to prevent liquid leakage.

**NOTE**

Before performing any maintenance operation on the pump, the instructions described in the "Stopping the Pump for Maintenance Tasks" section of the Operation section should be followed.

1. Remove the inlet and outlet manifolds.
2. Install a new set of ball or seats according to these assembly drawings. Tighten the manifold bolts and nuts with the appropriate torque.

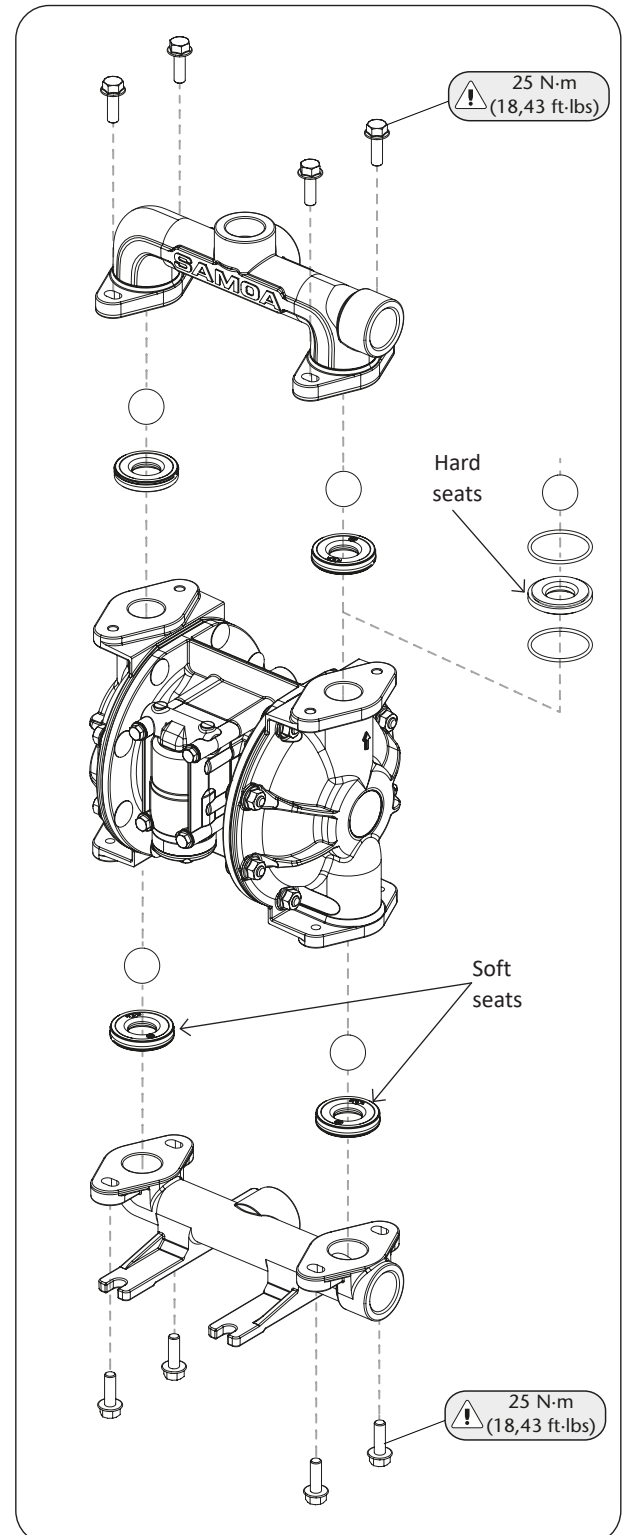
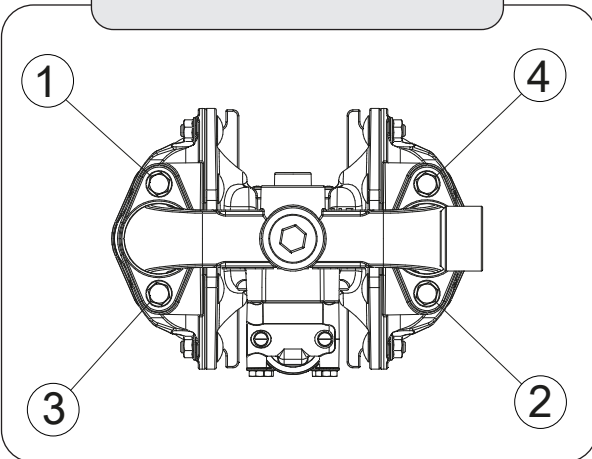
**CAUTION  
TIGHTENING SEQUENCE**

## f. Diaphragms



## NOTE

Before performing any maintenance operation on the pump, the instructions described in the "Stopping the Pump for Maintenance Tasks" section of the Operation section should be followed.

1. Unscrew the outlet manifold (A) and lift it. Remove the valve seats, o-ring (if applicable) and balls.
2. Turn the pump upside down to remove the inlet manifold (B) screws. Remove the seats, seals (if necessary) and balls.
3. Unscrew the fluid cover (C) screws and remove it by gently pulling back.
4. Remove the used diaphragm.
  - a) Conventional diaphragms (D): use an adjustable wrench and apply the appropriate torque on the fluid piston (E).
  - b) Two-piece diaphragms (F): use an adjustable wrench and apply the appropriate torque on the fluid piston (E).
5. Repeat for opposite side.

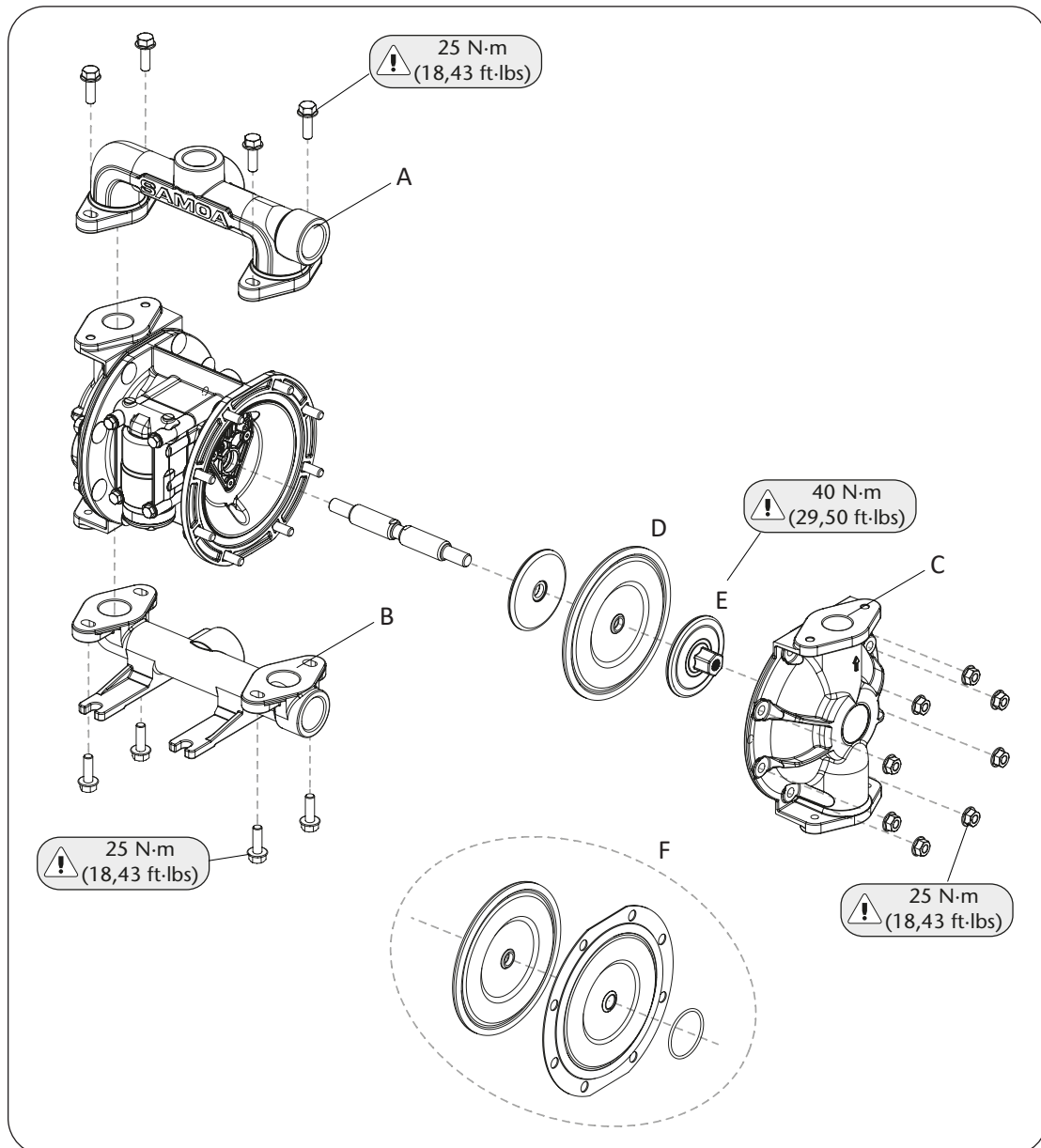





## EC DECLARATION OF CONFORMITY



## The manufacturer



SAMOA INDUSTRIAL, S.A., Pol. Ind. Porceyo, I-14 ·  
Camino del Fontán, 831 · 33392 - Gijón - Spain  
Tel: +34 985 381 488  
e-mail: info@samoaindustrial.com

Declares under its own responsibility, that the product:

**CP10X-XXX-XXX**  
**CP10 1" Double Diaphragm Metallic Pump**

complies with the directives: | 2006/42/CE

This declaration refers exclusively to the product in the state in which it was placed on the market, excluding added components and modifications made by the end user.

Pedro E. Prallong Álvarez  
Production Manager



# ***Balcrank***<sup>®</sup>

[www.balcrank.com](http://www.balcrank.com)

