

NEX.U[®]

FLUID MANAGEMENT SYSTEM



BOOST PRODUCTIVITY
INCREASE EFFICIENCY
REDUCE WASTE



Balcrank
Fluid Dispensing Systems

BALCRANK ELECTRONICS



QUALITY
EFFICIENCY
product

RELIABILITY

environmental
CONCERN

BALCRANK began in 1906 and is one of the oldest manufacturers of automotive lubrication products. Since its beginning we have been providing our customers with the best products for the ever changing Automotive, Commercial and Industrial markets. Our products service automotive, quick lubes, dealerships, fleet and commercial vehicle centers. Our product line has expanded, encompassing the heavy-duty market, which includes: trucking, municipalities, railroad, marine, industrial, and mining.



WHAT IS NEX·U®?

NEX·U® is an innovative fluid management system that provides the control and the information you require to make your operations more profitable. You will be able to account for every drop of lubricant or any other service fluid used. Additionally, you will efficiently keep inventory control, using automatic alerts and automatic reordering when needed, eliminating operation downtime. Accurate control of expensive lubricants and other service fluids makes that NEX·U® investment is quickly paid back, regardless of the shop's size.

NEX·U® COMPONENTS

U·TRACK SOFTWARE

- Manages work orders
- Tracks your transactions
- Monitors fluid Inventory
- System warning alerts
- Integrates with DMS
- Produces data reports

U·NET

- Controls and manages all functions and communications
- Includes U-track software

U·DAT

- System Keypad
- Provides access to NEX·U®
- Full colour touch screen and complete QWERTY Keypad

U·VISION+

- Hand-held display with keypad
- Bluetooth® communication with a single U-valve, U-meter+ or U-count

U·LINK

- Dispense gun with meter, valve and keypad
- Wireless communication with U-track software
- Accurate dispensing
- No cables required

U·VALVE

- All-in-one flow control unit with pulse meter, solenoid valve, filter and electronics
- Allows operation control and communication with other system components
- Bluetooth®

U·METER

- Pulse meter with electronics to control solenoid valve
- High accuracy
- Bluetooth® communication with U-vision and U-vision+ (U-meter+ only)

U·VISION

- Hand-held display module to fit a BALCRANK oil control handle
- It Includes a backlight display, connected via Bluetooth® with a U-valve, U-meter+ or U-count module

U·VIEW

- Remote, high visibility, LED display that shows the volume delivered through different U-valves / U-meter / U-count

U·TANK MODULE

- Monitors tank levels
- Avoids tanks running empty
- Avoids spillover
- Level alerts

U·CONNECT

- Canbus to WiFi® converter

U·COUNT

- U-count allows the use of any pulse meter and solenoid valve in the NEX·U® System

INSTALLATION CONFIGURATION

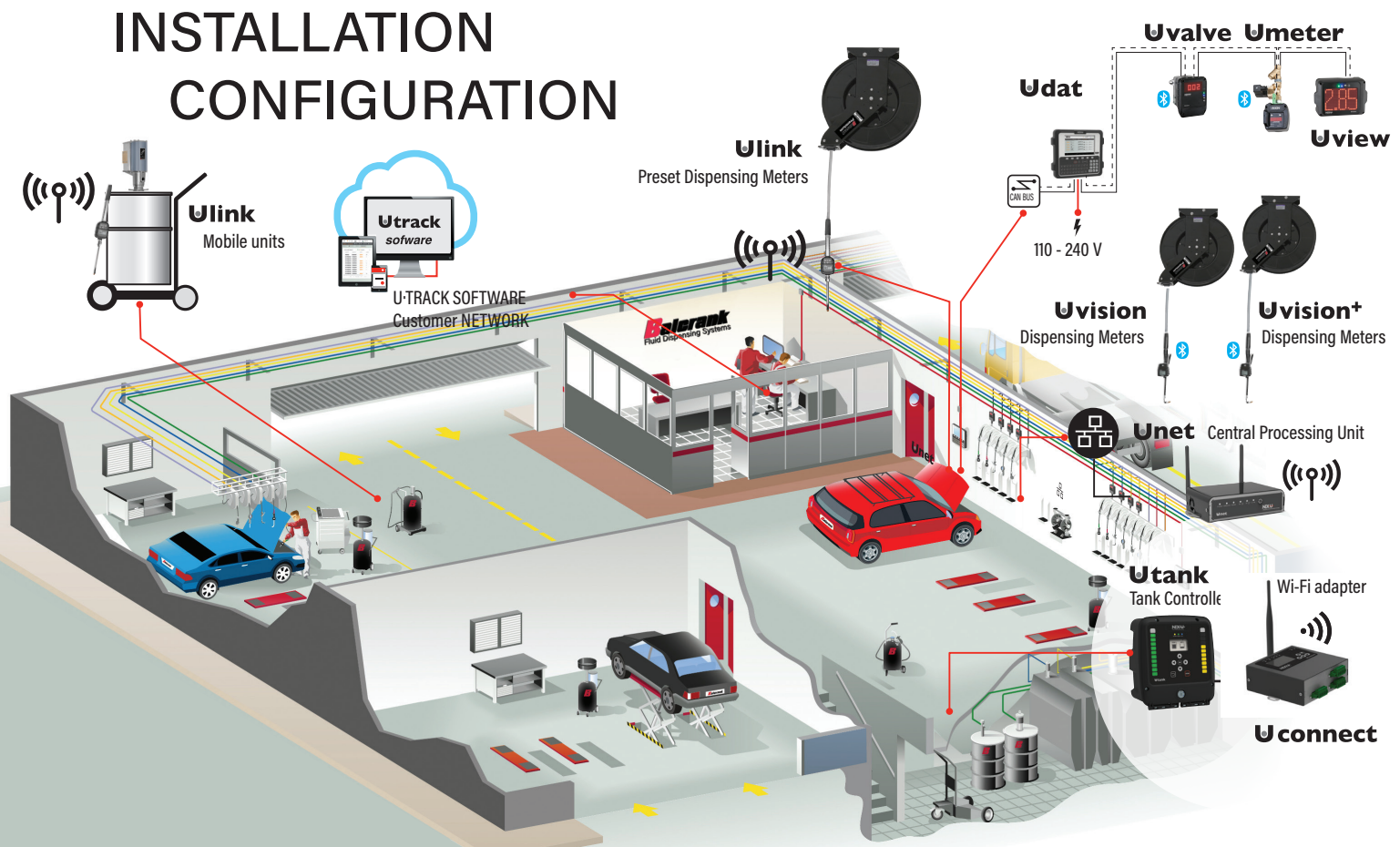

NEX-U[®] BY BALCRANK: Fluid management made easy

NEX-U[®] HYBRID TECHNOLOGY offers wired and wireless advantages for increased productivity

NEX-U[®] WIRED INSTALLATION

- Reliable connection
- No battery issues
- Increased reliability and dependability

NEX-U[®] WIRELESS INSTALLATION

- Reduces installation cost avoiding long cable runs
- Allows control of mobile dispensing units
- Simpler installation, with less components

KEEPING TRACK OF FLUIDS: Benefits of using a fluid management system



MONITOR



CONTROL



TRACK



BOOST PRODUCTIVITY
INCREASE EFFICIENCY
REDUCE WASTE



MAXIMIZE
PROFITABILITY &
REDUCE CARBON
FOOTPRINT

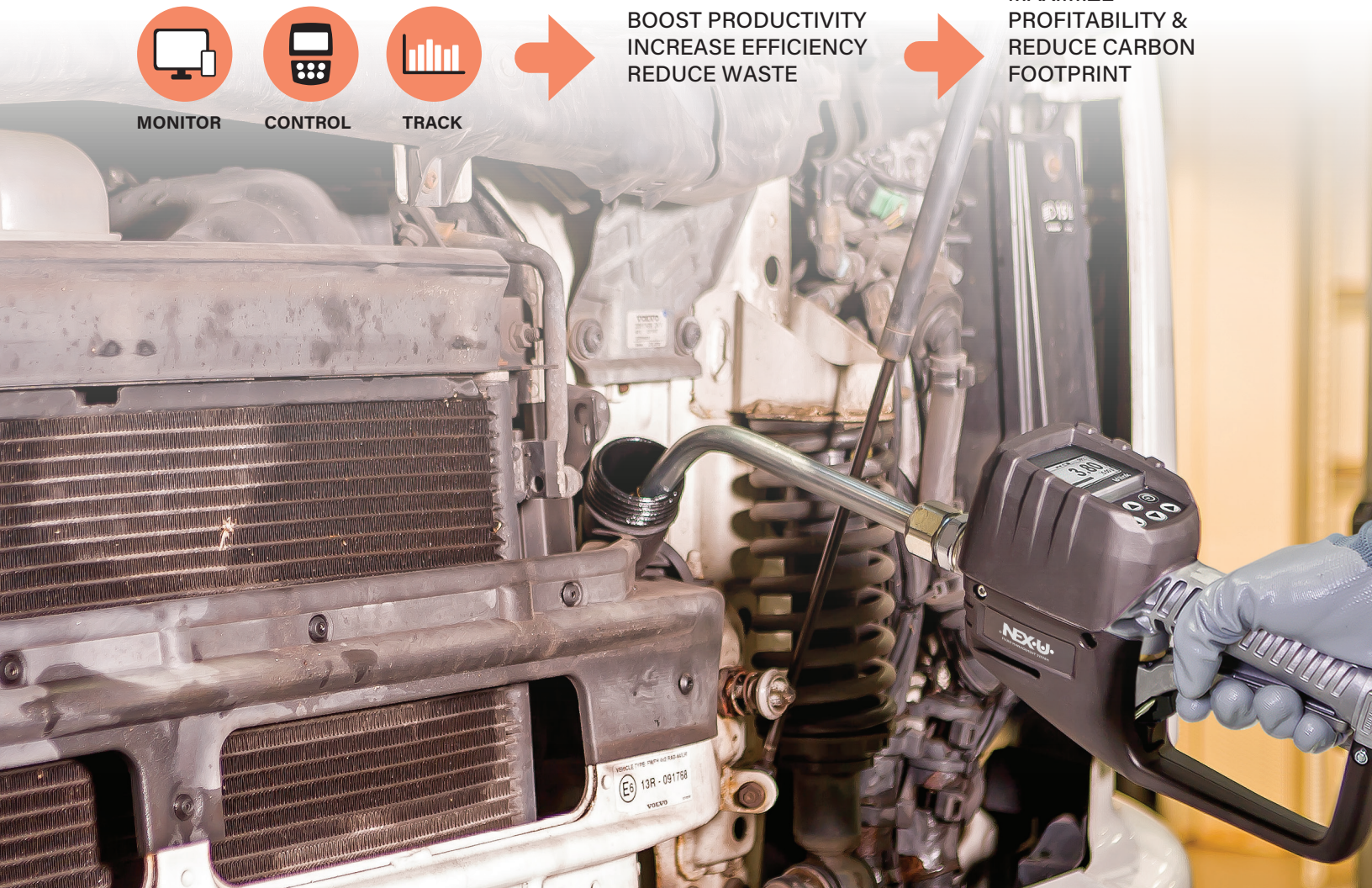

BENEFITS OF USING a Fluid Management System

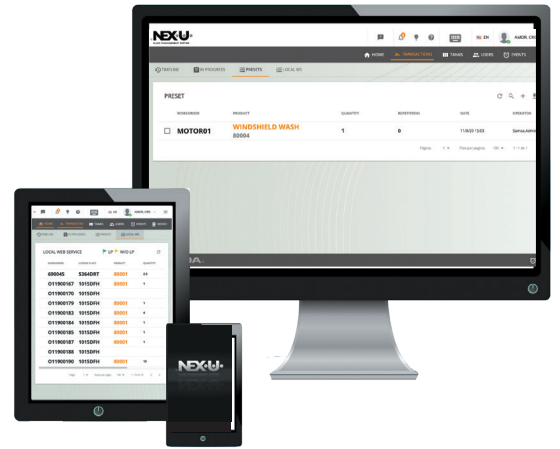

MONITOR

- Real time information about fluid transactions and inventory
- Inventory management (refills schedule, warnings, etc.)
- Automatic alerts

CONTROL

- Reliable dispensing
- Safety
- Accuracy

TRACK

- Account for every drop of lubricant and other vehicle service fluids used
- Reconcile fluid purchases and inventory with fluid sales and use
- Supervise technician activity

· DMS integration

LOST INVENTORY EQUALS LOST PROFIT. WITH TODAY'S HIGH OIL PRICES, INVENTORY CONTROL ELIMINATES THIS CONCERN.

- Increased reliability and fully track fluid transactions
- Improved productivity
- Accurate dispense
- Reduced downtime costs
- No tank stock-outs or spill-overs
- No tank refill delays

WHY NEX·U®?

HYBRID TECHNOLOGY

The system can be installed as a fully wireless system or as a wired system.
Possibility to control mobile units.

EASY OPERATION

Quick and easy data entry
Reduced in order preparation time
Reduced downtime due to oil shortage

INCREASED PRODUCTIVITY

Maintain control of service fluids.
Control every transaction from the dispensing valve, without walking back and forth.

DMS INTEGRATION

Optional API is available for integrations with 3rd party's DMS.

SIMPLE

Intuitive software
Plug & Play
Simple set-up

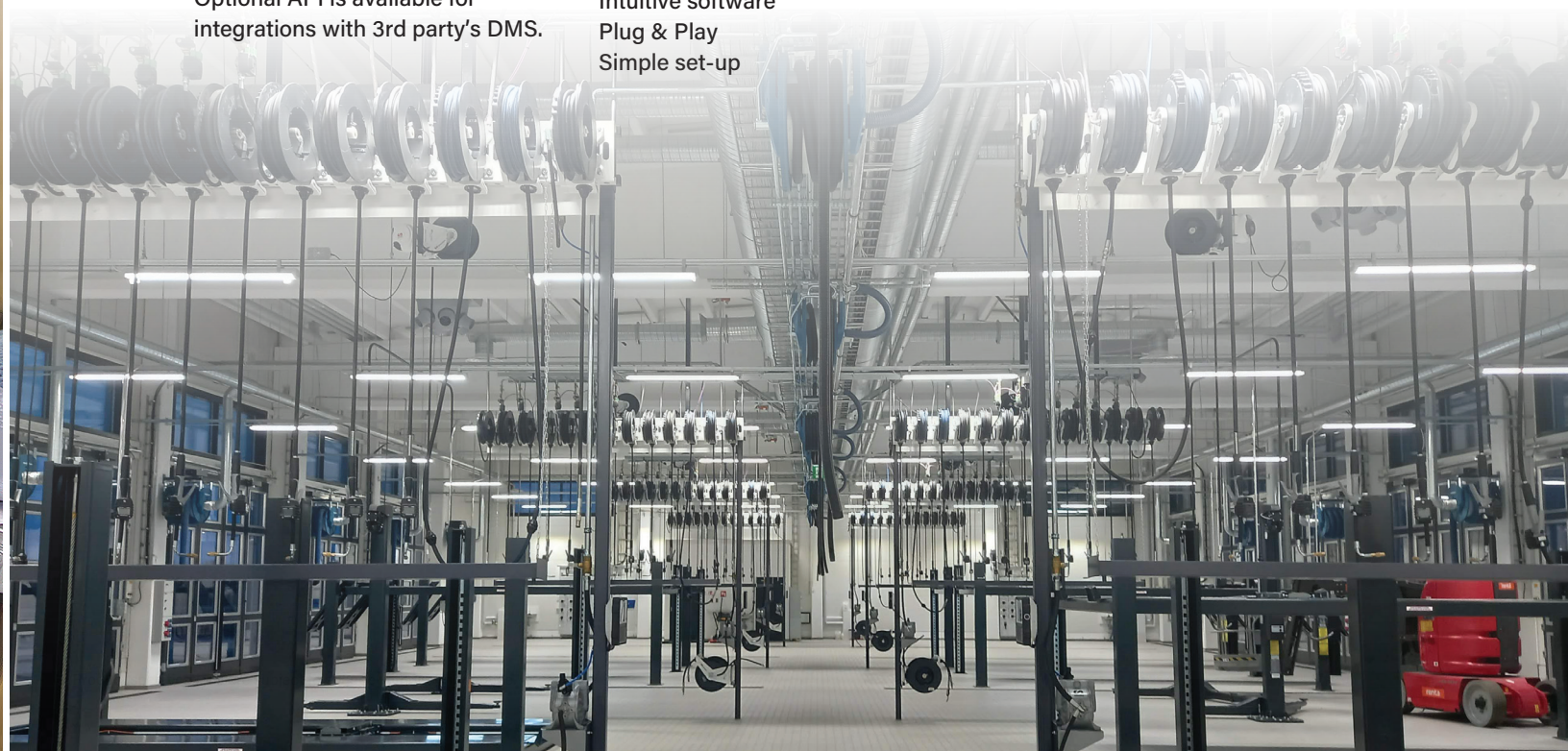

DMS - DEALER MANAGEMENT SYSTEM

NEX·U.® can interface with most popular DMS on the market, offering an efficient bi-directional communication between NEX·U.® and DMS

FEATURES

- Easy to use: quick and effective
- Enhanced security: work orders are checked and validated before fluid is dispensed
- Automation: simplifies data entering as it can be automatically downloaded from the DMS

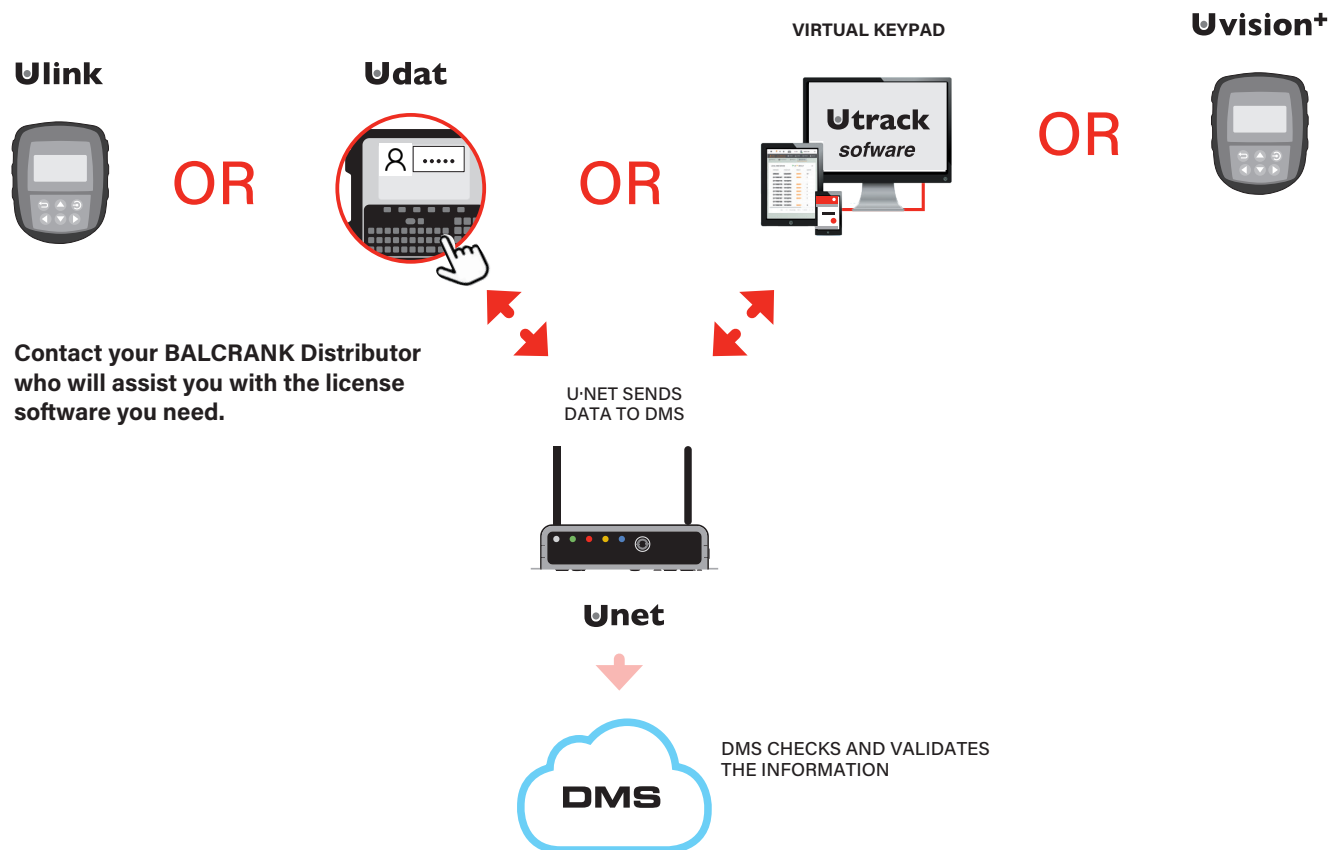

BALCRANK INTERFACE

A bi-directional communication is established through web service. The user enters their PIN and the work order number. DMS will prompt a message whether this information exists or not. NEX·U.® offers multiple dispensing modes depending on the customer needs.

DISPENSING MODE OPTIONS

1.1

STANDARD MODE USING U-DAT®

After entering PIN and work order number, the technician must select the type of fluid to be delivered, the hose reel number and enter the volume to deliver.

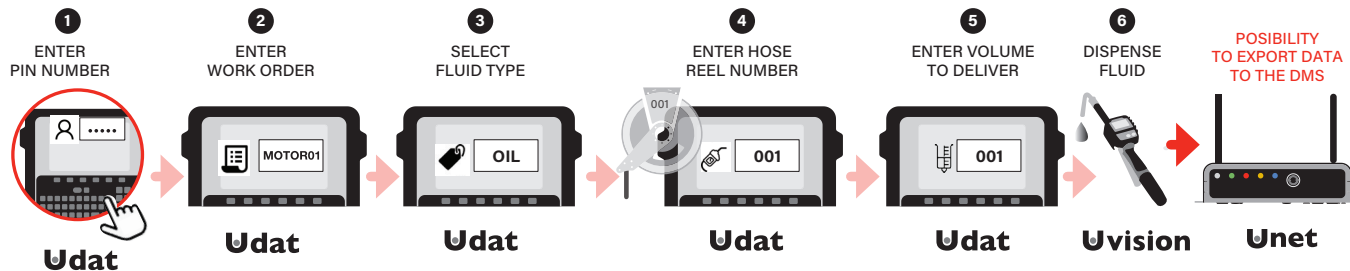

1.2

STANDARD MODE USING U-LINK® | U-VISION+®

After entering their PIN and work order number, the technician must enter the volume to deliver.



2.1

PRESET MODE USING U-DAT®

A previous set up must be done in U-track before validation, as figure 0 shows. After entering the PIN, work orders and hose reel numbers, the system downloads the preset volume of the type of fluid associated to the work order entered.

THE SHOP MANAGER MUST PREVIOUSLY ENTER THE FLUID AND VOLUME ASSOCIATED TO EACH ORDER NUMBER.

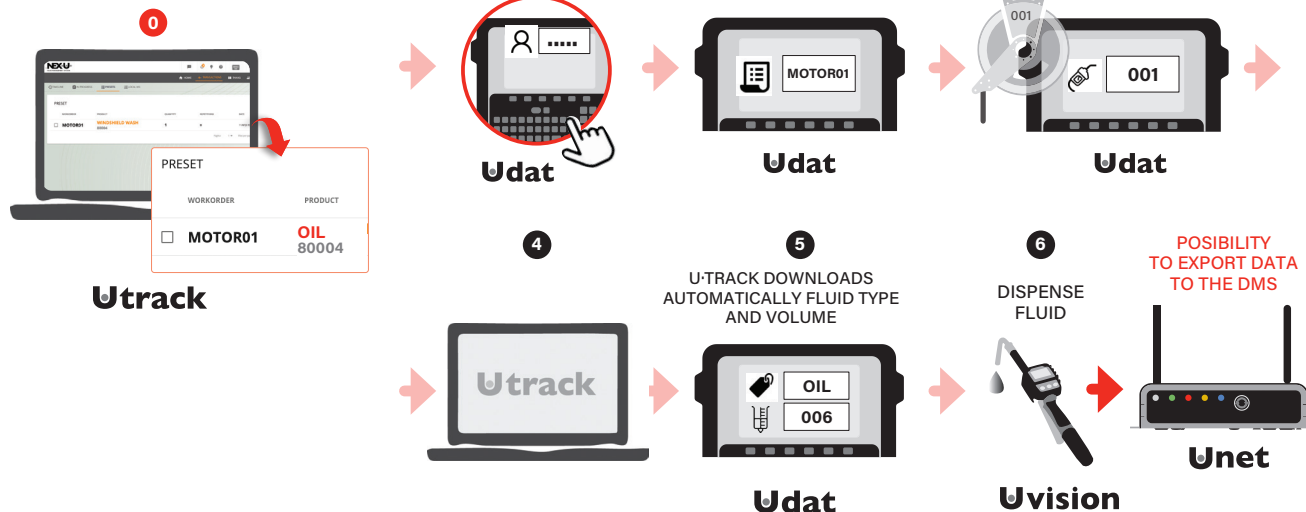

DISPENSING MODE OPTIONS

2.2

PRESET MODE USING U·LINK | U·VISION+

A previous set up must be done in U-track before validation, as figure 0 shows. After entering the PIN, the technician can scroll the existing work orders, and select the desired one. NEX·U· downloads the preset volume associated with the work order selected.

THE SHOP MANAGER MUST PREVIOUSLY ENTER THE FLUID AND VOLUME ASSOCIATED TO EACH WORK ORDER NUMBER.

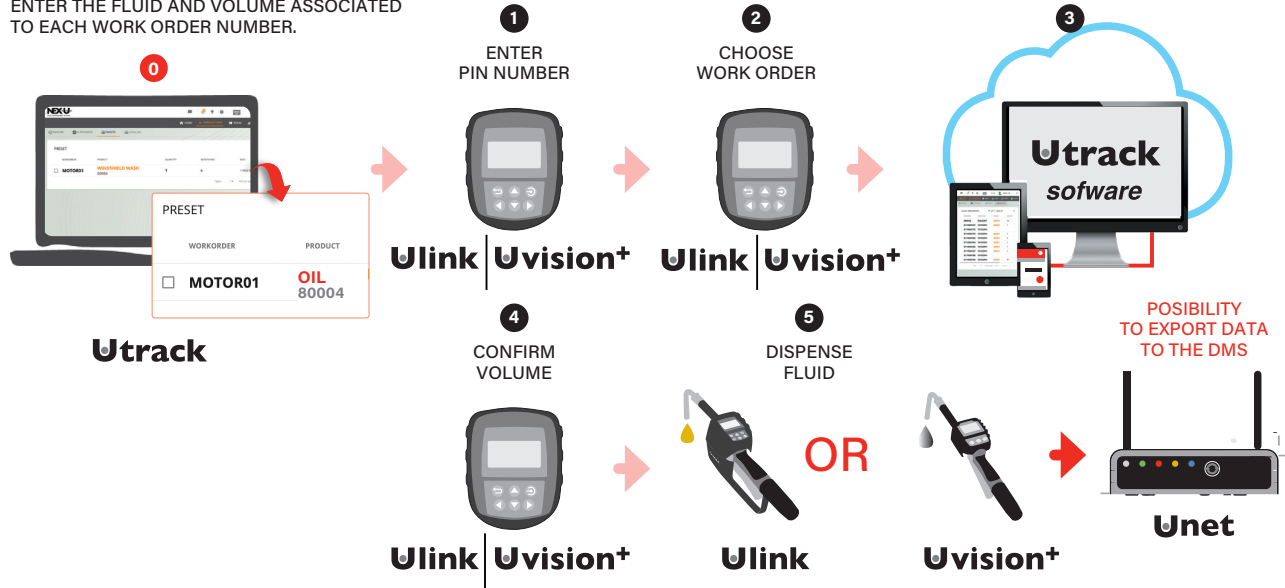

3

DMS - INTEGRATED MODE USING U·DAT, U·LINK, U·VISION+, VIRTUAL KEYPAD

From any device connected to the same network as the U-net, the user can launch the transaction, even through DMS integration, and then start it using U-dat, U-link or U-vision+

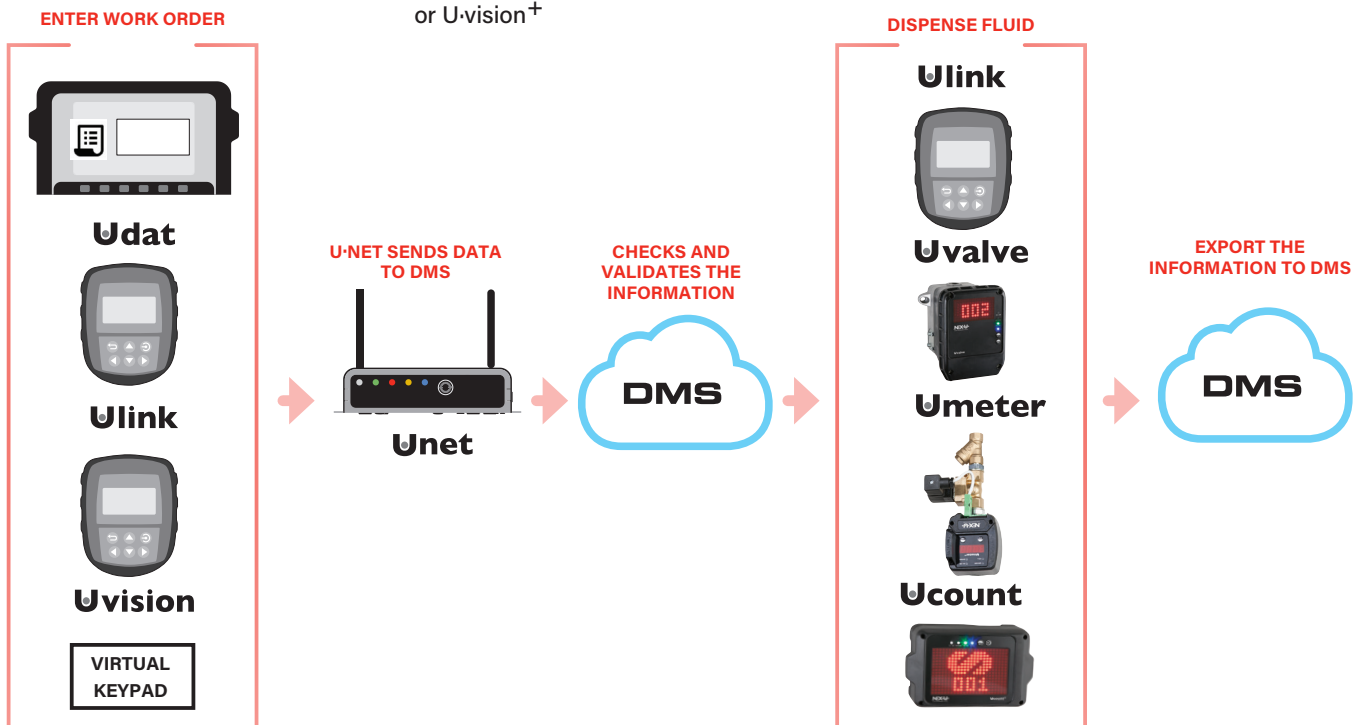

U-TRACK: NEX-U[®] SOFTWARE

Utrack

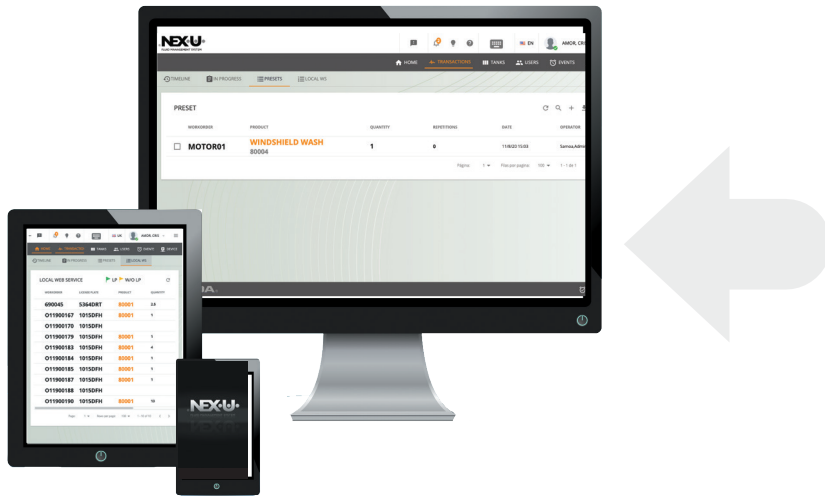

U-track system is a web based application accessible through any device (Laptop, PC, tablet or cell phone) connected to the same network as U-net. A Virtual Keypad license converts any device connected to NEX-U[®] into a virtual system access keypad for authorizing fluid dispense.

ID	WORKORDER	EXPENSE POINT	PRODUCT	QUANTITY	LICENSE PLATE	CREATION DATE	CREATOR BY
28	1247	MOBILELANT 006	MOTOR OIL	1,00	[1.00]	23/02/2017	Sarrah, Admin
24	46456	LANAU 009	MOTOR OIL	2,00	[2.00]	23/02/2017	Sarrah, Admin
22	12478	LANAU 001	MOTOR OIL	1,00	[1.00]	18/02/2016	Sarrah, Admin
21	1257	LANAU 001	MOTOR OIL	5,00	[5.00]	18/02/2016	Sarrah, Admin
20	121MA	MOBILELANT 006	MOTOR OIL	5,00	[5.00]	18/02/2016	Sarrah, Admin
19	22	LANAU 004	WINDSHIELD WASH	523.26	[523.26]	18/02/2016	USER
18	2458	MOBILELANT 006	MOTOR OIL	1,00	[1.00]	20/02/2016	Sarrah, Admin
17	1	MOBILELANT 0	MOTOR OIL	1,00	[1.00]	20/02/2016	Sarrah, Admin
16	690045	LANAU 001	MOTOR OIL	2,50	[2.50]	20/02/2016	Sarrah, Admin
15	7006	MOBILELANT 006	MOTOR OIL	2,00	[2.00]	20/02/2016	Sarrah, Admin
14	7005	LANAU 001	MOTOR OIL	1,00	[1.00]	20/02/2016	Sarrah, Admin
13	hgfgf	LANAU 001	MOTOR OIL	1,97	[1.97]	21/02/2016	CSBALUC, JAVIER
12	111	LANAU 001	MOTOR OIL	2,00	[2.00]	21/02/2016	USER

U-track dashboard screen provides, in a glance, information on oil inventory and oil usage. Just click on any tank for more information.

ID	WORKORDER	EXPENSE POINT	PRODUCT	QUANTITY	LICENSE PLATE	CREATION DATE	CREATOR BY
28	1247	MOBILELANT 006	MOTOR OIL	1,00	[1.00]	23/02/2017	Sarrah, Admin
24	46456	LANAU 009	MOTOR OIL	2,00	[2.00]	23/02/2017	Sarrah, Admin
22	12478	LANAU 001	MOTOR OIL	1,00	[1.00]	18/02/2016	Sarrah, Admin
21	1257	LANAU 001	MOTOR OIL	5,00	[5.00]	18/02/2016	Sarrah, Admin
20	121MA	MOBILELANT 006	MOTOR OIL	5,00	[5.00]	18/02/2016	Sarrah, Admin
19	22	LANAU 004	WINDSHIELD WASH	523.26	[523.26]	18/02/2016	USER
18	2458	MOBILELANT 006	MOTOR OIL	1,00	[1.00]	20/02/2016	Sarrah, Admin
17	1	MOBILELANT 0	MOTOR OIL	1,00	[1.00]	20/02/2016	Sarrah, Admin
16	690045	LANAU 001	MOTOR OIL	2,50	[2.50]	20/02/2016	Sarrah, Admin
15	7006	MOBILELANT 006	MOTOR OIL	2,00	[2.00]	20/02/2016	Sarrah, Admin
14	7005	LANAU 001	MOTOR OIL	1,00	[1.00]	20/02/2016	Sarrah, Admin
13	hgfgf	LANAU 001	MOTOR OIL	1,97	[1.97]	21/02/2016	CSBALUC, JAVIER
12	111	LANAU 001	MOTOR OIL	2,00	[2.00]	21/02/2016	USER

Transactions can be followed and monitored real time, if required. Thanks to U-track, each PC terminal or tablet connected to the same network used by NEX-U[®] is converted into an access keypad to the NEX-U[®] system are available for multiple dispense locations (additional Virtual Keypad licenses are required). U-track can also generate different reports that can be exported easily into CSV format.



SAE 5W30

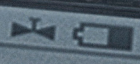

001

3.80



5.00 L

Ulink



NEX·U·

**WHEN
EVERY
DROP
COUNTS**



SYSTEM ACCESS AND CONTROL

NEX·U[®] adapts to the way you work offering multiple possibilities for accessing the system



Udat Udat power⁺

U-DAT ALLOWS SYSTEM ACCESS TO TECHNICIANS EITHER THROUGH A PIN CODE OR USING A RFID CARD

- U-dat includes a 7" full colour graphics display and a complete QWERTY keypad.
- U-dat supports CAN BUS cable communications that transmits data and power to open the solenoid valves in the system. "Plug-and-play" connectors make cabling easy.
- U-dat power includes the transformer required to simultaneously open up to 8 solenoid valves.
- U-dat requires 110 - 240 V 50/60 Hz power supply.
- Optional Bluetooth[®] printer (see accessories).

U-DAT ACCESS KEYPAD

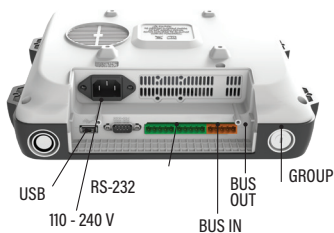

U-DAT CONNECTION PANEL

All wired connections can be quickly and easily done without opening the U-dat. It is possible to connect a printer, an external RFID reader, or a QR reader to the RS-232 port.

U-DAT

110 - 240 V AC
CAN BUS in/out

ORDERING INFORMATION

Part No.	Description
3110-100	U-dat power ⁺ Keypad NEX·U [®] access keypad with 7" colour screen and QWERTY Keypad. One USB, one RS232 and in/out CAN BUS ports. 110 - 240 V AC 50/60 Hz, with a 320 W transformer to open up to 8 solenoid valves, supports CAN BUS communications.
3110-104	U-dat Keypad Same as above, but with a 75 W transformer, to open up to 2 solenoid valves.
953001	Power cable C13EU2M (2 meters)

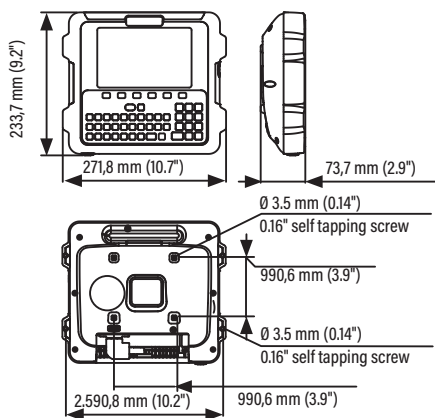

U·NET: NEX·U[®]

SYSTEM CENTRAL PROCESSING UNIT

U-net includes a powerful 2.4 GHz processor and 4 GB RAM. It controls the system functions and manages the wired and wireless communication among the NEX·U[®] components.

It has two CAN BUS ports (in/out) for wired communications with other NEX·U[®] components and an Ethernet port that allows U-net to connect to the LAN. It also deploys a dedicated radio frequency network for communication with U-link wireless metered dispense valves.

U·net



U-net specifications:

- Intel 2,4 GHz processor
- 4 GB RAM memory
- 64 GB storage capacity
- One Ethernet connection, one HDMI, four USB and two CAN BUS communication ports and Radiofrequency emitter
- 110-240V AC - 5V DC transformer included

ORDERING INFORMATION

Part No.	Description
3110-110	U-net central processing unit. Includes U-track software.
3110-133	Virtual Keypad license. Converts any terminal (PC, laptop, tablet or smart- phone) into a NEX·U [®] access keypad. Contact BALCRANK for further information regarding the Virtual Keypad license.

U·NET ALSO INCLUDES THE U·TRACK SOFTWARE

U-track is a powerful web based software package that gives you full control of fluid usage and inventory. It is a web based software that allows multi-user applications. All PCs or tablets in the same network can have access to U-track. U-track can work using any web browser. Compatible with: Chrome, Firefox, Microsoft Edge.

THANKS TO U·TRACK YOU WILL BE ABLE TO:

- Simple and intuitive system set-up
- Simplified system maintenance (manage users, fluid inventory, etc.)
- Manage all the system hard-wired and wireless communication
- Generate a wide variety of reports, which can be easily exported to csv and txt formats
- Transform any PC terminal in the workshop into a NEX·U[®] Virtual Keypad (license required)

U·TRACK ALSO CONTRIBUTES TO INCREASING YOUR OPERATIONS EFFICIENCY AND PROFITABILITY:

- Keeps control of every fluid drop dispensed in the system
- Improves inventory accuracy, generating automatic warnings and email notifications for reorders at critical predefined inventory levels
- Generates a variety of reports, to help you track dispense information such as date and time, technician, work order, fluid dispensed, volume delivered, etc.

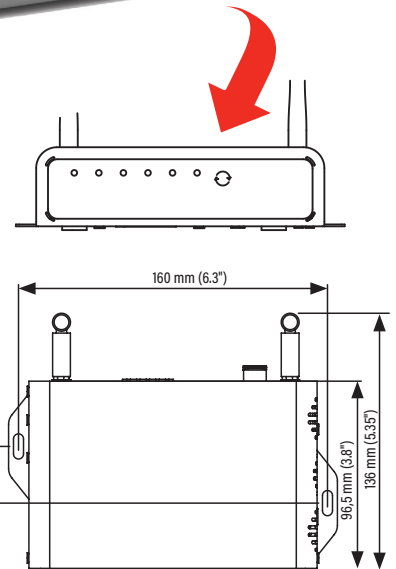

U·VISION⁺: HAND-HELD DISPLAY AND KEYPAD MODULE

U·vision+ includes a six-button keypad and it can replace the U·dat Keypad for data entry in the system as it allows the following operations:

- User access through PIN entry.
- Scroll through existing open job orders to select the one corresponding to each operation or enter the job order number (can do alphanumeric).
- Enter the volume of fluid to be dispensed.
- Confirm fluid type and transaction.

U·vision+ has a backlight display connected using Bluetooth® with a U·valve, U·meter+ or U·count and it displays the following parameters:
U·vision+ is powered with 4 "AA" 1.5 V alkaline batteries.

U·vision⁺

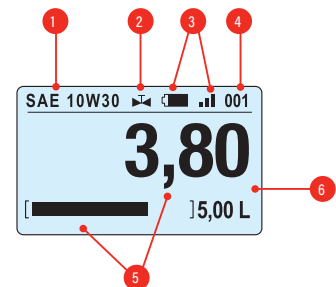

- 1 Fluid dispensed type
- 2 Solenoid valve open or closed
- 3 Battery life and Bluetooth® signal
- 4 Hose reel / fluid outlet number
- 5 Volume delivered and operation progress
- 6 Preset volume

Two possible dispensing modes: Standard and Preset



U·vision+ adapts to any BALCRANK 1/2" fluid control handle and transforms the handle into a hand-held display and keypad for access to the NEX·U.® system.

ORDERING INFORMATION

Part No.	Description
3110-113	U·vision+ hand-held keypad and display module. (Gun not included).

U-LINK: WIRELESS DISPENSING METER VALVE

Ulink

- Dispensing Meter Valve with wireless communication
- Includes hand held System Access Keypad that allows full transaction control



Increased durability
Protective TPE shroud

Reliable valve operation
Valve automatically shuts off once the delivered flow reaches the preset volume

Easy and intuitive operation
6-key integrated keypad with large LCD screen

Easy to replace batteries
Four AA standard alkaline batteries provide the power required for an effective valve operation

Light and Robust
Aluminium die cast for longer life and lighter weight

Easy to operate
Four finger trigger for increased user comfort

Heavy Duty inlet swivel with inlet filter
1/2" High flow inlet swivel with protective TPE swivel boot

Product Name

Qty Dispensed

Required Qty

Back / Cancel Button

Set Button

Control / Insert Scroll

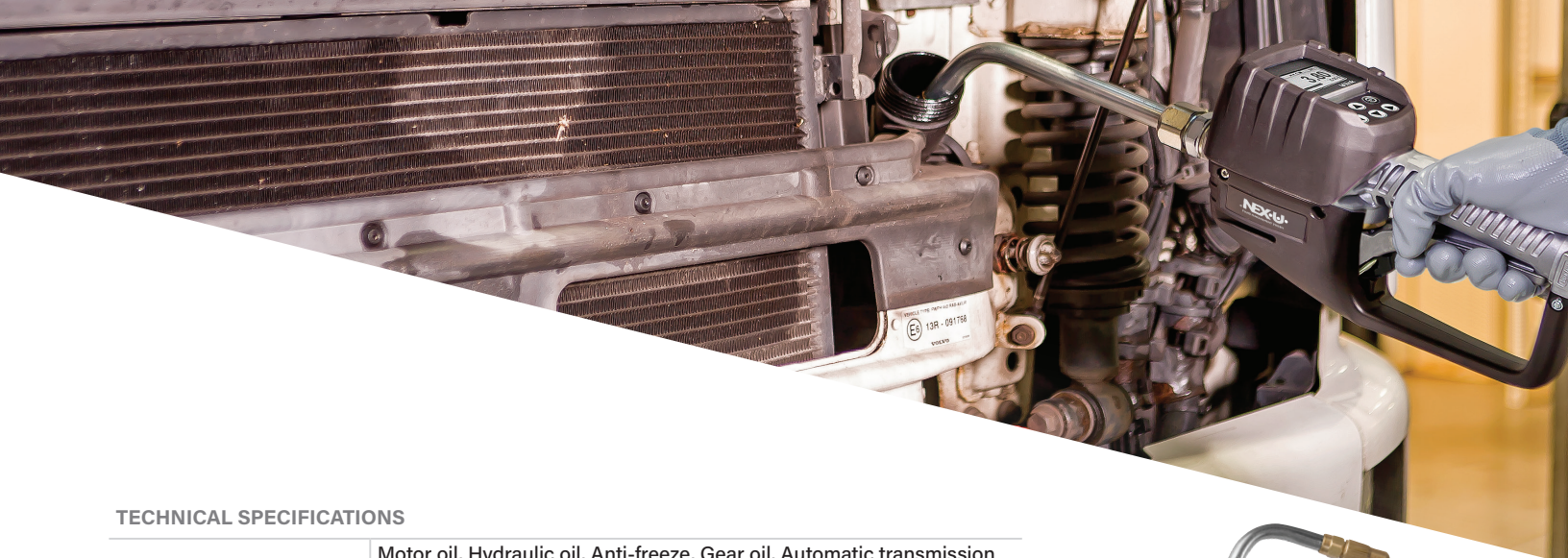

TECHNICAL SPECIFICATIONS

Fluids handled	Motor oil, Hydraulic oil, Anti-freeze, Gear oil, Automatic transmission fluid
Flow range	1 to 30 l/min (0.25 to 7.5 gal/min)
Maximum working pressure	100 bar (1,425 psi)
Accuracy	± 0.5 % (Oil); ± 1% (Anti-freeze solutions)
Inlet	1/2" NPT (F)
Outlet	1/2" NPT (F)
Working temperature range	-10 °C to 50 °C (14 °F to 122 °F)
Battery	4 x "AA" Alkaline 1.5V
Viscosity Range	Up to 2000 mPa.s
Display	LCD
Wetted parts	Aluminium, AISI 316 Stainless Steel, Buna-N, Delrin, Brass, Zinc plated steel
Weight (with no outlet)	4,6 lb (2,1 kg)



Category	Specification
Regulatory Approvals	FCC (EEUU), ETSI (Europe), IC (Canada), KCC (Korea), TELECK (Japan), RCM (Australia), Anatel (Brazil)
Frequency band	ISM 2.4 GHz, DSSS (Direct Sequence Spread Spectrum)
Protocol	Wireless Radio Frequency communication
Encryption	128/256 bit AES

ORDERING INFORMATION

Part No.	Description
3110-125	U-link, no outlet
3110-153	U-link, with 60° rigid outlet and 1/4 turn non-drip tip
3110-154	U-link, with 90° flexible outlet and 1/4 turn non-drip tip

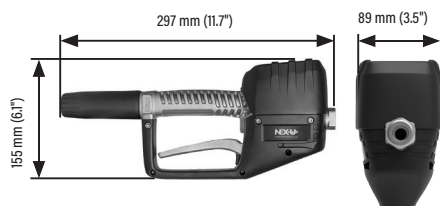

VOLUME METERS

U-VALVE: COMPACT UNIT OF PULSE METER, SOLENOID VALVE, FILTER AND COMMUNICATIONS

Uvalve

U-Valve is a compact unit that combines a high accuracy pulse meter, a solenoid valve and a large, cleanable fluid screen filter with an electronic module. The electronic module controls the meter and valve operation



Uconnect

U-valve can connect to the WiFi[®] network using U-connect



PRODUCT SPECIFICATIONS

Applications	Lubricants, antifreeze solutions*
Wetted parts	Aluminium, NBR, stainless steel, acetate
Connection threads	1/2" NPT (F)
Flow range	1 - 30 l/min
Pulses per litre	328 ppl
Accuracy	+/- 0,5 %
Max. working pressure	100 bar
Solenoid valve	24 V DC
Communication	CAN BUS, Bluetooth [®]

* If fluid additives are used, it is recommended to install stainless steel pulse meter and stainless steel solenoid valve.

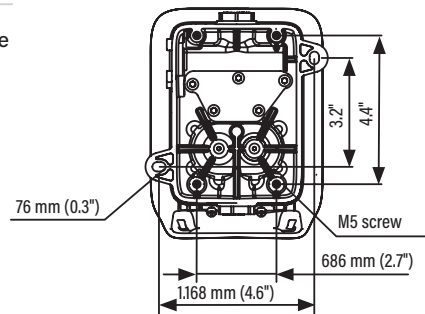
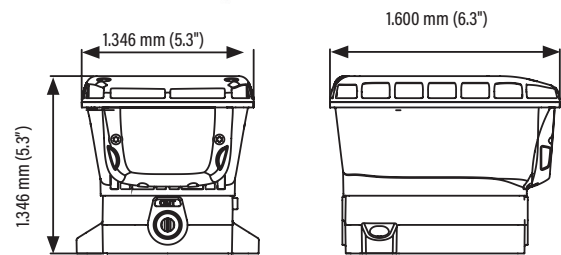

U-valve and U-valve+ wired connections use fast connection in/out CAN BUS terminals.

U-valve cable connectors are not included (see accessories).

ORDERING INFORMATION

Part No.	Application
3110-115	U-valve meter, solenoid valve and electronic module. Includes Bluetooth [®] communication for connecting to a U-vision or U-vision+.

U-meter U-meter+

High accuracy, compact pulse meter including the electronic module required to control the meter, the solenoid valve operation and the communication with other system components through CAN BUS.



U-meter+ includes Bluetooth[®] for connecting to a U-vision or U-vision⁺.

U-meter Part No.	3310-139	3110-122	3110-120	3110-118
Wetted parts	Aluminium, NBR, stainless steel, acetal	Aluminium, NBR, stainless steel, acetal	PVC, Vectra [®] , stainless steel, Viton [®]	Stainless steel, Vectra [®] , Viton [®]
Applications	Lubricants	Lubricants, diesel	DEF/AdBlue [®] , windshield wash and antifreeze solutions (low pressure)	DEF/AdBlue [®] , windshield wash and antifreeze solutions (high pressure)
Connection threads	1/2" NPT (F)	3/4" NPT (F)	1/2" NPT (F)	1/2" NPT (F)
Flow range	0.25-7.5 gal/min. (1 - 30 l/min)	2-21 gal/min. (8 - 80 l/min)	0.25-13 gal/min. (1 - 50 l/min)	0.25-13 gal/min. (1 - 50 l/min)
Pulses per litre	328 ppl	109 ppl	320 ppl	320 ppl
Accuracy	+/- 0.5 %	+/- 0.5 %	+/- 0.5%	+/- 0.5%
Max working pressure	1,450 psi (100 bar)	1,450 psi (100 bar)	435 psi (30 bar)	1,450 psi (100 bar)
Communications	CAN BUS	CAN BUS	CAN BUS	CAN BUS
U-meter+, models with Bluetooth[®] Part No.	3110-117	3110-123	3110-121	3110-119

Only for connection with U-dat, U-valve, or an adjacent U-meter. Requires a 24 V DC solenoid valve.

U-METER AND SOLENOID VALVE KITS

THE U-METER AND SOLENOID VALVE KITS INCLUDE A HIGH-PRECISION U-METER OR U-METER+ METER, A SOLENOID VALVE, AND A Y-STRAINER.

Part No.	Application	Pulse meter	Solenoid valve	Y-strainer
3110-125	Lubricants, antifreeze solutions	U-meter 3110-139	3120-217	3120-211
3110-126	Lubricants, antifreeze solutions	U-meter+ 3110-117	3120-217	3120-211
3120-127	High delivery lubricants, antifreeze solutions	U-meter 3110-122	3120-218	3120-212
3110-128	High delivery lubricants, antifreeze solutions	U-meter+ 3110-123	3120-218	3120-212
3110-130	DEF / AdBlue [®] , windshield wash (low pressure)	U-meter 3110-120	3120-226	3120-211
3110-131	DEF / AdBlue [®] , windshield wash (low pressure)	U-meter+ 3110-121	3120-226	3120-211

NEX-U⁺ requires 24 V DC, normally closed except for overflow (normally open) solenoid valves to operate. U-valve and U-valve+ include a solenoid valve. For other metering elements, a solenoid valve compatible with the fluid and the application requirements must be used.



Part No.	Application and wetted materials	Connection threads	Voltage	Type	Max. Working pressure
3120-217*	Oil and antifreeze solutions. Brass and NBR	1/2" NPT (F)	24 V DC	N.C.	50 bar (125 bar)
3120-218	Coolant, diesel, water, oil. Brass and NBR	1/2" NPT (F) High Flow	24 V DC	N.C.	50 bar (125 bar)
3120-033	Compressed Air. Brass and NBR	3/8" NPT (F)	24 V DC	N.C.*	200 psi (13 bar)
3120-225	Compressed Air. Brass and NBR	1/2" NPT (F)	24 V DC	N.C.*	200 psi (13 bar)

N.C.= Normally closed. / N.O.= Normally open. * For use in standard delivery applications, with a 1/2" U-meter.

NEX·U[®] REMOTE DISPLAYS

Ucount

U-count allows the use of any pulse meter and solenoid valve in the NEX·U[®] system. U-count control module includes a high visibility LED display and the software required to communicate with the rest of the NEX·U[®] system components.

U-count support CAN BUS hard wired cabling to transmit power, required to open the solenoid valve, and data, for communication with other system components. It can also communicate with a U-vision or U-vision⁺ using Bluetooth[®].



U-COUNT DIMENSIONS

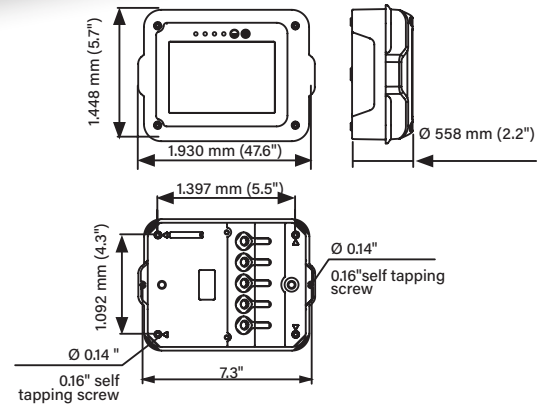

Uvision

Hand-held display module to fit a BALCRANK oil control handle. Includes a backlight display connected via Bluetooth[®] with a U-valve, U-meter⁺ or U-count module and it displays the following parameters:

- Hose reel (fluid outlet number and fluid dispensed type).
- Battery life and Bluetooth[®] signal strength.
- Volume delivered and operation progress.
- Solenoid valve open or closed.



ORDERING INFORMATION

Part No.	Description
3110-112	U-vision hand-held display module. (Outlet and handle not included).

- 1 Fluid dispensed type.
- 2 Solenoid valve open or closed.
- 3 Battery life and Bluetooth[®] signal.
- 4 Hose reel / fluid outlet number.
- 5 Volume delivered and operation progress.
- 6 Preset Volume.

Uview



Remote, high visibility, LED display that shows the volume delivered through various U-valves / U-meter / U-count / U-meter⁺ (no simultaneous operation supported). U-view supports and no hardwired communication. U-view requires no hardwired connection (data and power) to a U-dat Keypad or to a 110 - 240 V AC power supply using a 24 V DC (U-power or U-power⁺).

ORDERING INFORMATION

Part No.	Description
3110-134	U-view remote display module

NEX-U[®] CONNECTABILITY ACCESSORIES

Upower

Upower⁺



3110-106 & 3110-108



3110-146

Power supply to dispensing units and other system components. U-power connects using CAN BUS cable to a U-valve, U-valve⁺, U-meter, U-meter⁺ or U-count whenever the power supplied by a U-dat Keypad is not present.

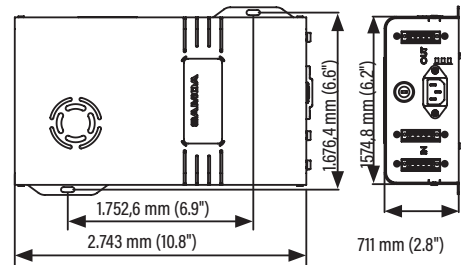

ORDERING INFORMATION

Part No.	Description
3110-108	U-power. Power supply unit with a 75 W transformer for use with 2 solenoid valves.
3110-106	U-power ⁺ . Power supply unit with a 320 W transformer for use with 8 solenoid valves with 2 CAN BUS connectors.
3110-146	U-power ⁺ . Power supply unit with a 320 W transformer for use with 8 solenoid valves with 3 CAN BUS connectors (1 IN and 2 OUT).

RF NETWORK EXTENDER

ORDERING INFORMATION

Part No.	Description
3110-151	Expands the NEX-U [®] Radio Frequency network coverage to reach remote areas.



3110-151

Uconnect

CANBUS TO Wi-Fi CONVERTER



3110-145

ORDERING INFORMATION

Part No.	Description
3110-145	U-connect allows wireless communication among the different components instead of CAN BUS wired communication. Equipped with an external antenna, it allows for extended WiFi [®] signal coverage.

U-TANK: TANK LEVEL MONITOR MODULE AND PUMP CONTROLLER

Utank



Provides real-time inventory control, reducing concerns about inventory shortage or used fluid tanks overflow

Tank Monitoring

It is a monitor module capable of controlling two tanks using digital or analog level gauges. Can be connected to solenoid valves, to control pump operation, and to external warning devices.

U-tank communicates with other NEX-U[®] components using CAN BUS wired connection or WiFi[®] wireless connection (requires U-connect).

U-tank has two independent graphic displays and level bars. Each of them shows the inventory available in each tank. It also has a set-up keypad for inventory adjustment if required. ⁽¹⁾

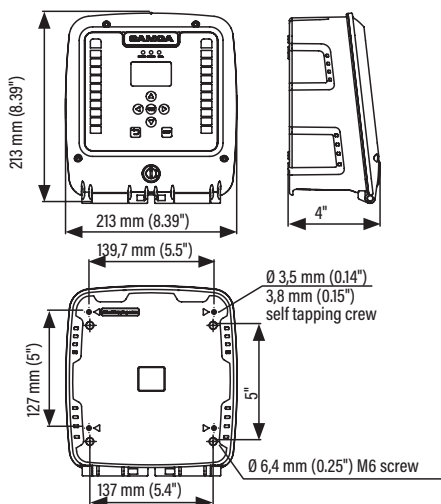

INPUT AND OUTPUT PORTS

- One analog input per tank for a pressure probe with 4-20 mA or 0-10 V interface.
- Three digital inputs per tank for a low, intermediate or high-level probe ⁽¹⁾.
- One output per tank for a solenoid valve to control air supply to each pump.
- One output per tank for an electro-pneumatic valve to prevent tank overflow.
- One output per tank for controlling a flash warning light or an acoustic alarm. U-tank supports CAN BUS wired communication with other NEX-U[®] system components. It requires a 110 - 240 V AC supply.
- One common output for controlling an air solenoid valve to stop the air supply to all pumps when the workshop is closed.

- 1 U-tank
- 2 Level sensors
- 3 Pressure gauge
- 4 Solenoid valve
- 5 Remote flash light or siren
- 6 CAN BUS
- 7 U-connect

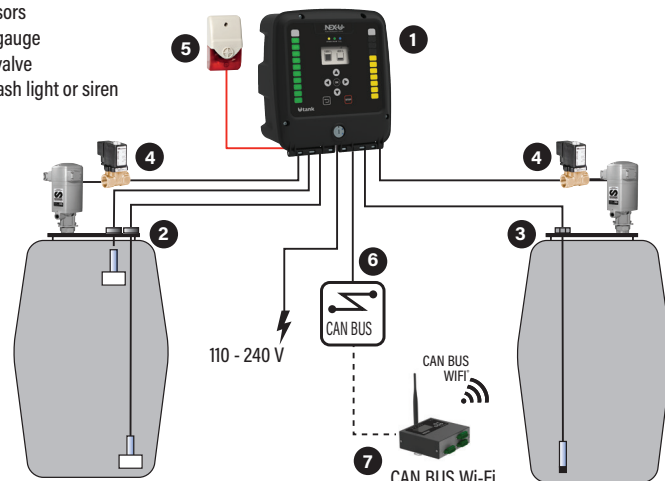

ORDERING INFORMATION

Part No.	Description
3110-105	U-tank tank monitoring module. Can control up to two tanks. Supports CAN BUS communications. 110 - 240 V

⁽¹⁾ The use of digital probes does not allow real-time inventory monitoring. NEX-U[®] will use declining balance for inventory control and will require manual inventory adjustment when fluid is supplied to the tank.

NEX·U·[®] COMPACT

NEX·U·[®] also offers solutions to smaller workshops where web based software is not needed. NEX·U·[®] COMPACT is a simple system based in a special U-dat Keypad that is able to control a maximum of 8 dispensing points.

The Keypad includes a 7" color screen and the simplified software included provides workshops with:

- Full control of bulk stored fluid usage.
- Inventory control using declining balance method. NEX·U·[®] COMPACT will give a warning signal once a certain inventory is reached, and restricts access to those outlets that have run out of inventory.
- Ability to generate full reports in CSV format that can provide useful management information.
- Does not support U-Link oil dispensing meter or U-vision⁺.



NEX·U·[®] COMPACT can work with any NEX·U·[®] fluid meter: U-valve; U-meter or U-meter⁺ with solenoid valve and filter. A U-vision hand held display can be connected to each U-valve or U-meter⁺ or U-count. NEX·U·[®] COMPACT has 64 GB storage capacity that provides virtually an unlimited capacity for storing transactions. NEX·U·[®] can be configured from a computer connected to the same Wi-Fi network as the NEX·U·[®].

New Wi-Fi functionalities.

ORDERING INFORMATION

Part No.	Description
3110-101	NEX·U· [®] COMPACT 75. With a 75 W transformer for opening up to 2 solenoid valves.
3110-103	NEX·U· [®] COMPACT 320. With a 320 W transformer for opening up to 8 solenoid valves.

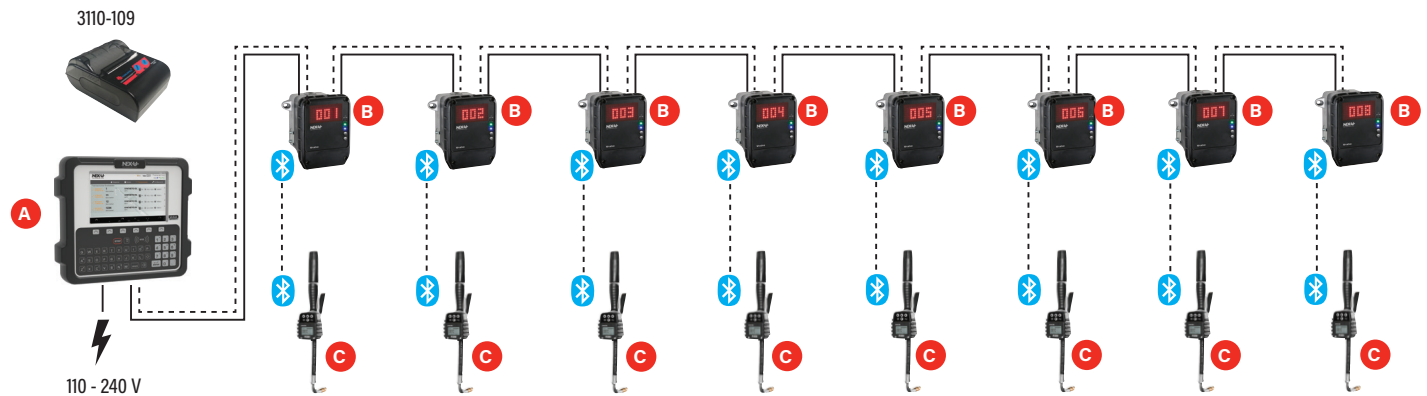

NEX·U·[®] COMPACT keypad **A** can control up to 8 dispensing points (model with 320 W transformer) or up to 2 dispense point (model with 75 W transformer). Each dispensing point **B** can include a U-valve, a U-meter or U-meter⁺ with solenoid valve combination. A U-vision hand held display **C** can be connected to each fluid outlet using Bluetooth[®] communications. It is possible to include a Bluetooth printer to provide a ticket for the transactions.

NEX-U[®]

ACCESSORIES

TANK MONITORING ACCESSORIES

Part No.	Description
3120-084	Tank level pressure gauge. Allows real-time monitoring of the volume in a tank. Maximum tank height: 4 m (13.1') taller tanks by special order



3120-084

Part No.	Description
3120-079	Float switch digital level gauge. Detects minimum, intermediate or maximum volume in a tank. Does not allow real-time monitoring. Adjustable height, includes 5 m (16.4') cable



3120-079

Part No.	Description
3120-029	Remote flash and acoustic alarm



3120-029

CABLE

3082A 15/18AWG COMMUNICATION AND POWER CAN BUS CABLE

Part No.	Description
3130-110	NEX-U/100' CAN BUS Communication Cable
3130-500	NEX-U/500' CAN BUS Communication Cable
3130-100	NEX-U/1,000' CAN BUS Communication Cable
3110-136	Cable connectors kit
3110-141	In/out electrical connectors. For use with U-meter, U-meter ⁺
3110-143	Jumper cable 1.5' cable with prewired connectors 3130-136 for connecting adjacent elements with a CAN BUS cable

3130-110
3130-500
3130-100



3130-136



3110-143



SOLENOID VALVES FOR COMPRESSED AIR - PUMP CONTROL

Part No.	Application and wetted materials	Connection threads	Voltage	Type	Max. Working pressure
3120-033	Compressed Air. Brass and NBR	3/8" NPT (F)	24 V DC	N.C.*	200 psi (13 bar)
3120-225	Compressed Air. Brass and NBR	1/2" NPT (F)	24 V DC	N.C.*	200 psi (13 bar)

* N.C.= Normally closed. / N.O.= Normally open.

3120-033
3120-225

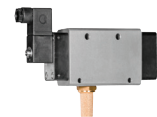

BLUETOOTH PRINTER

Part No.	Description
3110-109	Optional printer for use with NEX-U [®] COMPACT, and NEX-U [®] U-dat connected via Bluetooth [®] to the U-dat or Nex-U [®] compact

3110-109



BAR CODE READER

Part No.	Description
3110-140	Bar code laser reader. Reads any QR code. For use with a U-dat, U-dat Power+ and U-dat for NEX-U [®] mobile and compact systems

3110-140



U-VALVE BRACKETS

Part No.	Description
2230-040	Allows fixing up to 6 U-valve on top of a hose reel stand (360 160)

2230-040



CREATING A WIRELESS NETWORK

There are two ways to create a wireless network:

- Using an existing Wi-Fi network. Requires access to existing wireless network credentials.
- Creating a dedicated Wi-Fi network. New wireless credentials are created for this network.

In both cases IP addresses, network and default gateway, are required. The key component is U-net.

USING AN EXISTING NETWORK

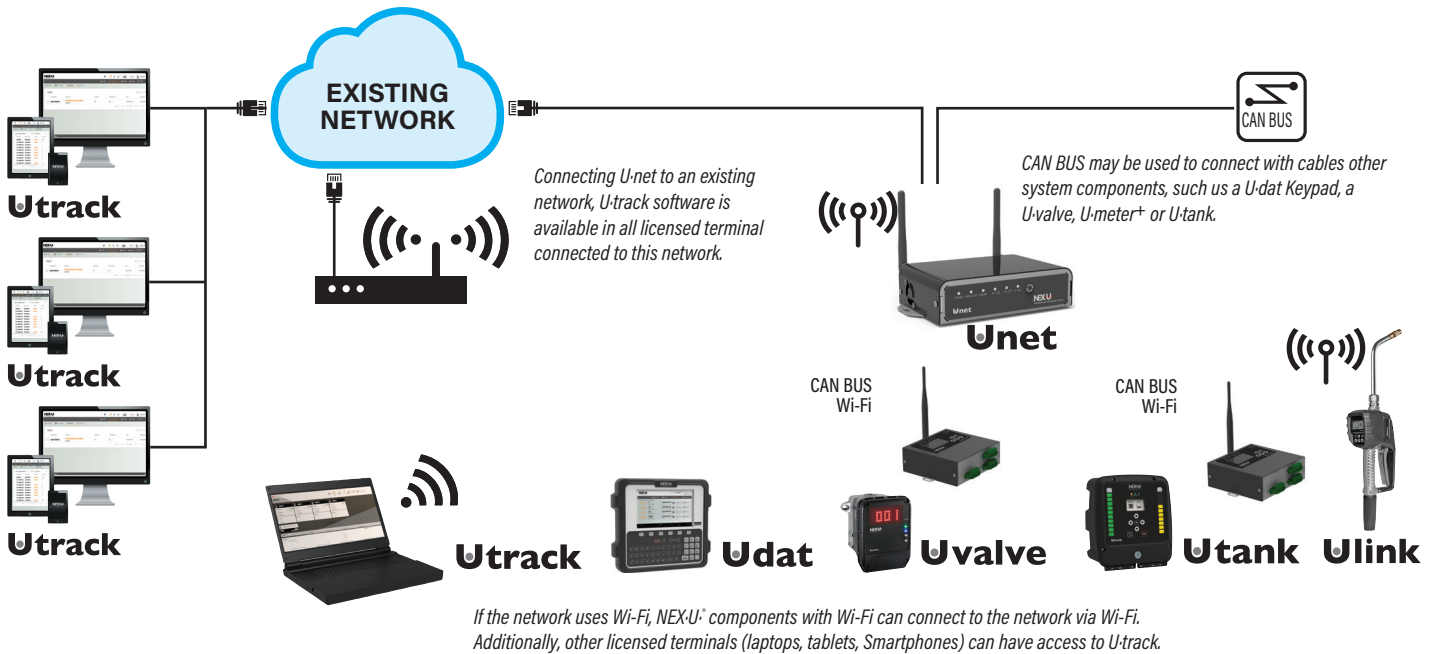

CREATING A NEW NETWORK

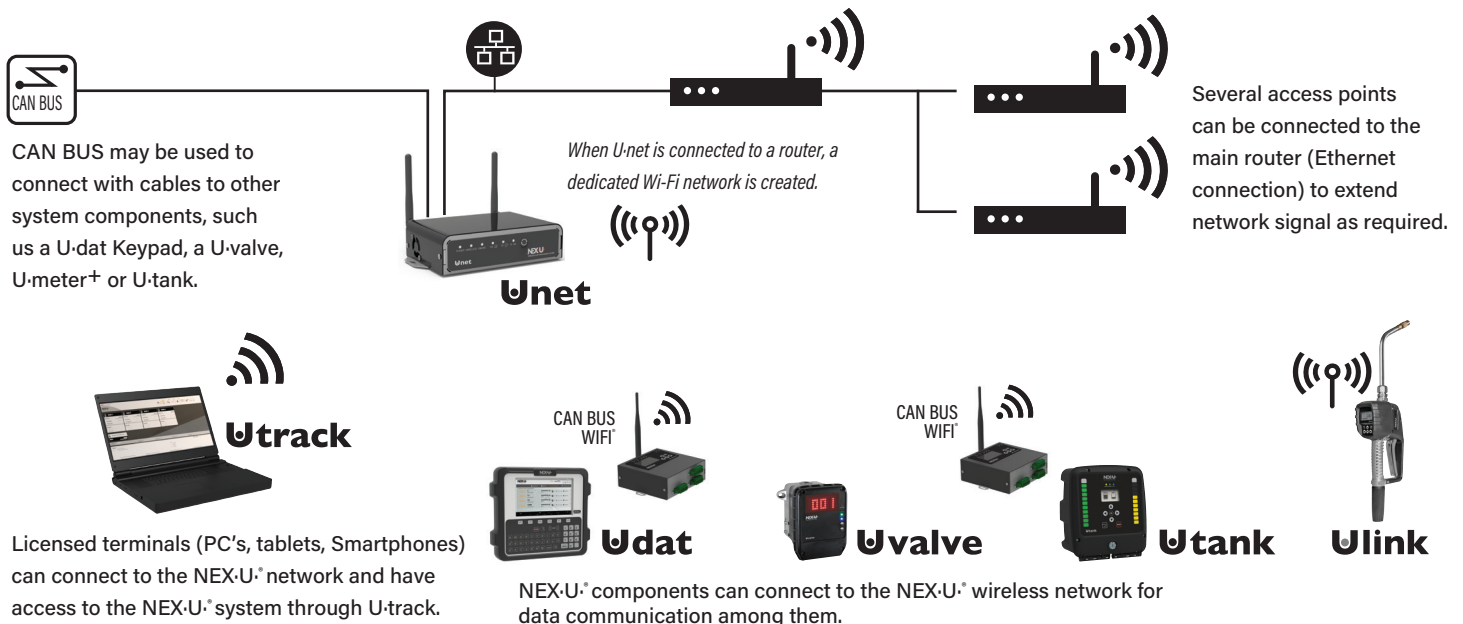

INSTALLATION EXAMPLES

NEX-U® provides maximum flexibility in the way the user interacts with the system, the most effective connection method and enhanced reporting capability.

ACCESS THROUGH U-dat

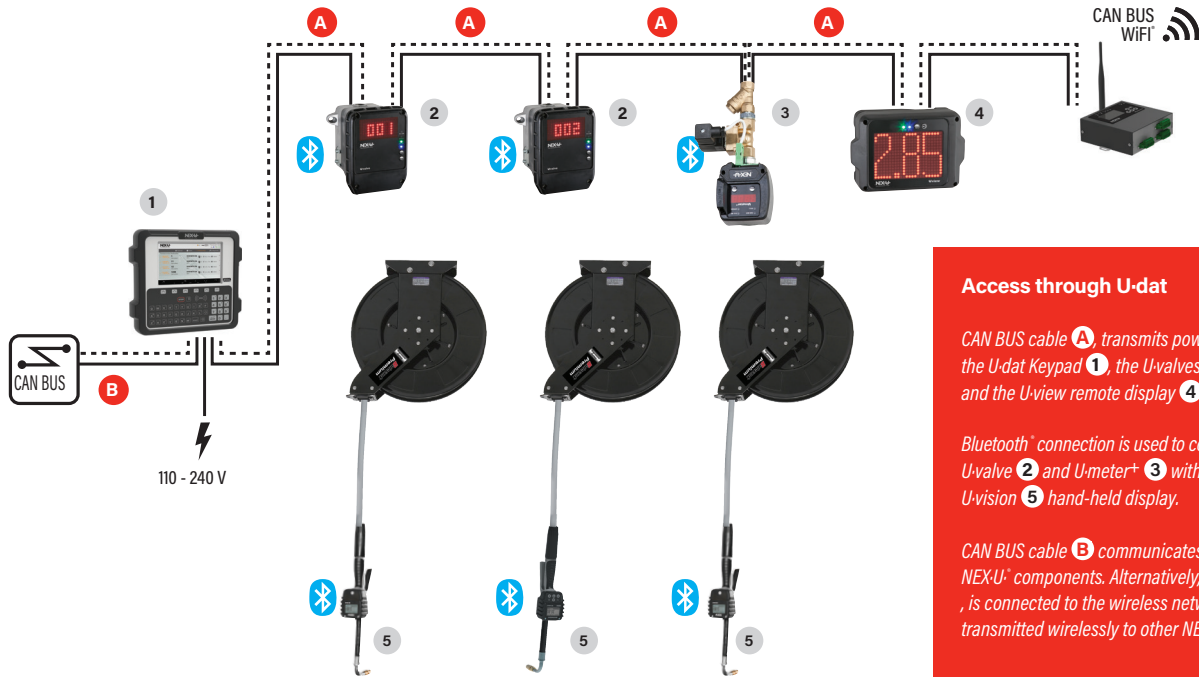

Access through U-dat

CAN BUS cable **A**, transmits power and data between the U-dat Keypad **1**, the U-valves **2**, the U-meter+ **3** and the U-view remote display **4**.

Bluetooth™ connection is used to communicate each U-valve **2** and U-meter+ **3** with its corresponding U-vision **5** hand-held display.

CAN BUS cable **B** communicates with other NEX-U™ components. Alternatively, if the keypad **1**, is connected to the wireless network, data can be transmitted wirelessly to other NEX-U™ components.

ACCESS THROUGH U-vision+ or U-link

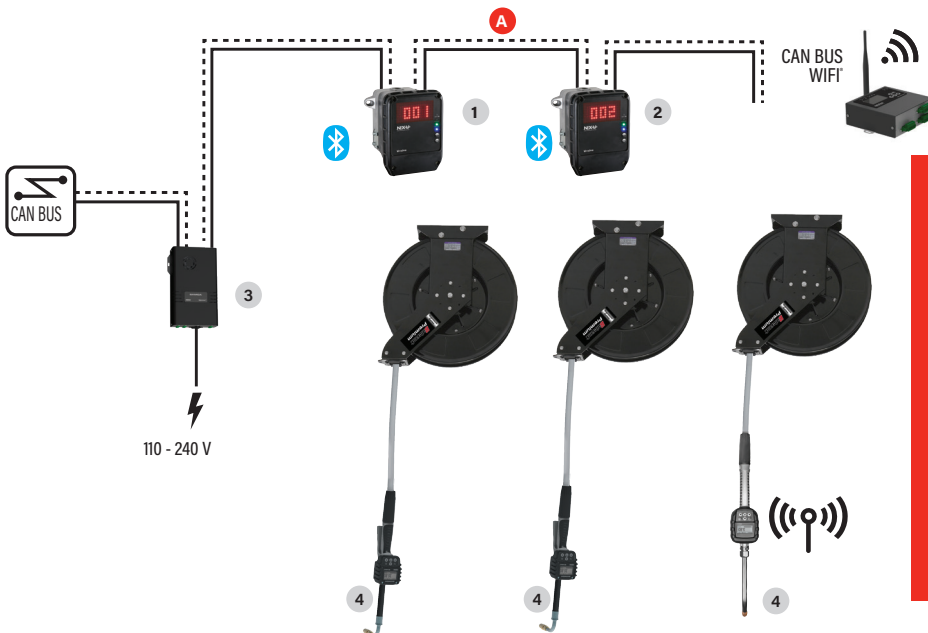

Access through U-vision+

Power and data are transmitted using CAN BUS cable **A** between the Uvalve **1** and the other Uvalve **2**. Power to energize the solenoid valves is supplied by the U-power **3**, connected to Uvalve **1**.

Each Uvalve **1** and Uvalve **2** is connected to its corresponding U-vision+ **4**, hand-held display and systems access keypad.

Wireless data transmission is done by Uvalve **1**.

TANK MONITORING



CAN BUS FAST CONNECTION

U-dat, U-valve, U-meter, U-count, U-tank and U-net use in/out CAN BUS fast connectors that make cabling easier, quicker and prevent disconnections.

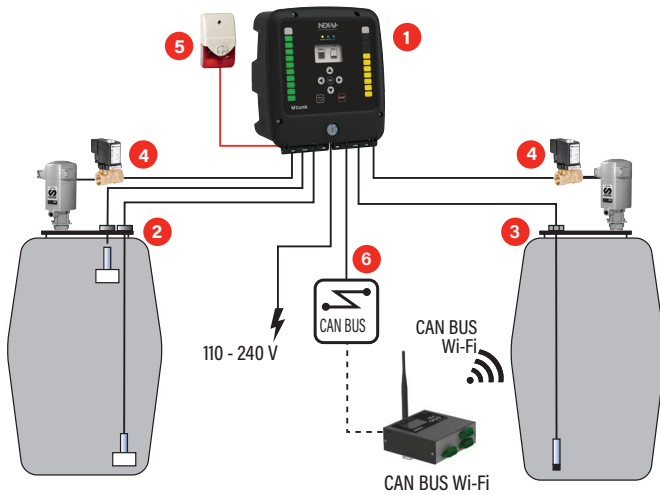

U-tank 1 can monitor up to two tanks. Each tank can be fitted with low and high level sensors 2 or with a pressure gauge 3 for real-time control of the inventory in the tank. U-tank 1 can also control pump operation opening or closing an air solenoid valve 4 that prevents pump from running dry or air entering the oil distribution lines if there is no oil in the tanks.

U-tank 1 can also control a remote flash light or siren 5 to warn when any tank is empty.

U-tank 1 can communicate with other NEX-U® elements using Wi-Fi or through CAN BUS 6 wired connection.



Balcrank

Fluid Dispensing Systems

Balcrank Corporation

90 Monticello Road
Weaverville, NC 28787, USA
Tel.: (800) 747-5300 or (828) 645-4261
Fax: (800) 763-0840 or (828) 658-0840
info@balcrank.com
www.balcrank.com
www.shopbalcrank.com

Customer Support

Tel.: (800) 747-5300 or (828) 645-4261
(Monday to Friday, 8:00 AM - 5:00 PM ET)

- Order entry
- Product availability and information
- Pricing
- Shipping dates and delivery information
- Return Merchandise Authorization

Technical Support

Tel.: (800) 747-5300 or (828) 645-4261
(Monday to Friday, 8:00 AM - 5:00 PM ET)

- Repair advice
- Product application recommendations
- Warranty claims and returns
- Service bulletins

Place an Order

Tel.: (800) 747-5300 or (828) 645-4261

Fax: (800) 763-0840 or (828) 658-0840

- Fax orders day or night
- Order confirmed next business day by fax or e-mail

E-mail: orders@balcrank.com

Online: www.shopbalcrank.com

- Upload to Cart feature
- Place orders online 24/7
- Four convenient ways to shop
- Search by product name or number
- Browse the site and add to cart
- Copy past orders to create a duplicate order
- Rapid order entry feature
- Pricing is live and specific to your account
- Build, print, save, and manage quotes for access at a later date
- Track shipped orders
- Easy management of personnel access and assigned permissions